



CONSUMER PRODUCT SAFETY COMMISSION

16 CFR Parts 1112 and 1250

[CPSC Docket No. CPSC-2024- 0027]

Safety Standard for Toys: Requirements for Water Beads

AGENCY: Consumer Product Safety Commission.

ACTION: Final rule.

SUMMARY: Section 106(a) of the Consumer Product Safety Improvement Act of 2008 (CPSIA) mandates that ASTM F963 shall be a mandatory toy safety standard. This safety standard sets forth requirements for water bead toys and toys that contain water beads. Under this statutory authority, the U.S. Consumer Product Safety Commission (CPSC or Commission) is issuing a safety standard for water bead toys and toys that contain water beads.

DATES: The rule is effective on [INSERT DATE 90 DAYS AFTER DATE OF PUBLICATION IN THE FEDERAL REGISTER]. The incorporation by reference of the publication listed in this rule is approved by the Director of the Federal Register as of [INSERT DATE 90 DAYS AFTER DATE OF PUBLICATION IN THE FEDERAL REGISTER]. The incorporation by reference of certain other material listed in this rule was approved for use by the Director of the Federal Register as of April 20, 2024.

FOR FURTHER INFORMATION CONTACT:

Sara E. Brown, Compliance Officer, Office of Compliance, Consumer Product Safety Commission, 4330 East West Highway, Bethesda, MD 20814-4408; telephone: 240-749-0572; email: sebrown@cpsc.gov or Matthew Kresse, Project Manager, Division of Mechanical Engineering, Directorate for Laboratory Sciences, Consumer Product Safety Commission, 5 Research Place, Rockville, MD 20850; Telephone 301-987-2222; email: mkresse@cpsc.gov.

SUPPLEMENTARY INFORMATION:

I. Background and Statutory Authority

A. Background

Section 106(a) of the CPSIA made ASTM International's (ASTM) voluntary standard for toys, ASTM F963–07, *Standard Consumer Safety Specification for Toy Safety* (except section 4.2 and Annex 4), a mandatory safety standard for toys beginning 180 days after the enactment date of the CPSIA. 15 U.S.C. 2056b(a). The CPSIA states that ASTM F963 shall be considered a consumer product safety standard issued by the Commission under section 9 of the Consumer Product Safety Act (15 U.S.C. 2058). Since 2009, CPSC has enforced ASTM F963 as a mandatory standard for toys.^{1,2} In 2017, the Commission established 16 CFR part 1250, Safety Standard Mandating ASTM F963 for Toys, and incorporated by reference the newly revised ASTM standard at that time, ASTM F963–16. 82 FR 8989 (Feb. 2, 2017). Most recently, on January 18, 2024, the Commission updated part 1250 to incorporate by reference the 2023 revision, ASTM F963–23. 89 FR 3344.

Section 4.40 of ASTM F963–23 includes requirements for toys, including but not limited to, water beads, that are made of expanding materials.³ However, the requirements currently in ASTM F963–23 for this category of toys are insufficient to address all known water bead toy hazards. Potential hazards for expanding materials in general include gastrointestinal tract blockage if a child ingests a product comprised of expanding materials. The hazard mitigation provisions in ASTM F963–23 include performance requirements but do not include warnings or instructional literature specifically tailored to the expanding materials requirements. While sections 5, 6, and 7 of ASTM F963–23 provide “Labeling Requirements,” “Instructional Literature” requirements, and “Producer’s Markings” requirements generally for toys under the standard, none of these requirements is directed to water bead toys specifically. Thus, the generalized warnings and instructional literature requirements do not address all known hazards.

¹ Since 2009, ASTM has revised F963 five times: ASTM F963–08, ASTM F963–11, ASTM F963–16, ASTM F963–17, and ASTM F963–23 (approved August 1, 2023).

² Section 3.1.91 of ASTM F963–23 (Toy): “Any object designed, manufactured, or marketed as a plaything for children under 14 years of age.”

³ Under ASTM F963, “expanding materials” are defined as “any material used in a toy which expands greater than 50% in any dimension from its as-received state.”

Incident data, described in the preamble of the NPR and section III of this preamble, demonstrate that children ingest water beads, aspirate and choke on them, or insert them into the nose or ear, and subsequently suffer injury or death. Staff's testing of water bead toys, described in the preamble of the NPR, further demonstrates that tested water beads that pass the performance requirements in ASTM F963–23 can still pose safety hazards. Accordingly, this rule under section 106 of the CPSIA creates additional requirements in part 1250 to establish mandatory requirements specifically for water bead toys. Further, this rule revises the title of part 1250 from “Safety Standard Mandating ASTM F963 for Toys” to “Safety Standard for Toys,” to reflect the inclusion of requirements that do not incorporate by reference existing requirements in ASTM F963.

B. Statutory Authority

The Commission is authorized to issue this final rule pursuant to both section 106(c) and (d) of the CPSIA. 15 U.S.C. 2056b(c) and (d). Section 106(c) requires the Commission to periodically review and revise its mandatory toy safety standards to ensure that such standards provide the highest level of safety for toys that is feasible. Section 106(d) further requires the Commission to examine and assess the effectiveness of its mandatory toy safety standards in protecting children from safety hazards, and to promulgate consumer product safety rules that are more stringent than the existing standards if the Commission determines that more stringent standards would further reduce the risk of injury associated with such toys. Consistent with the consultation requirement in section 106(d)(1) of the CPSIA, staff has worked with the ASTM F15.22 Subcommittee Task Group since 2009 to update the toy standard and discuss hazards associated with water bead toys. This consultation, including the sharing of staff's assessment of hazards and staff's suggested additional performance and labeling requirements, continued through the revision and publication of ASTM F963–23.

C. Notice of Proposed Rulemaking (NPR)

On September 9, 2024, the Commission published an NPR to address four identified hazard patterns associated with water bead toys that are not adequately addressed by the current mandatory standard provisions addressing expanding materials: (1) ingestion of water bead toys, (2) insertion of water bead toys into the nose or ear, (3) aspiration due to water bead toys, and (4) choking due to water bead toys. 89 FR 73024. The Commission proposed adding additional performance requirements to part 1250 to better address these risks. The NPR also proposed establishing acrylamide level limits for water bead toys in response to toxicity hazards when water bead toys containing acrylamide enter the body, and implementing new testing requirements for acrylamide in water bead toys under part 1250. Finally, the Commission proposed labeling requirements for water bead toys under part 1250, including mandating warnings and instructional literature on products within scope of the proposed rule.

D. Final Rule Overview

Pursuant to section 106 of the CPSIA, 15 U.S.C. 2056b, the Commission is issuing a mandatory standard for water bead toys based on the proposed requirements in the NPR, with certain modifications in response to public comments and other clarifications, which are discussed in detail in sections V and VI of the preamble.⁴ The final rule defines a “water bead” as “a various shaped liquid absorbent polymer, composed of materials such as, but not limited to, polyacrylamide and polyacrylate, which expands when soaked in liquid.” This rule is intended to reduce the risk of injury or death associated with children ingesting, inserting into their ear or nose, aspirating, or choking on water bead toys by setting a maximum expansion size limit for water bead toys. The rule also is intended to reduce the risks of acrylamide exposure from water bead toys, by setting limits on the amount of allowable acrylamide in water bead toys. Finally, the rule requires strongly worded, conspicuous warnings.

⁴ On August 21, 2025, the Commission voted (2-0) to publish this final rule.

Based on comments received on the NPR and clarifications found to be necessary to the rule, the following changes have been made in the final rule:

- The references to “water” in the definition of water bead in proposed section 1250.4(b) has been revised to the broader term “liquid” in the final rule.
- In section 1250.4(c)(1) of the final rule, the proposed funnel test gauge diameter has been reduced from 9.0 mm to 5.0 mm; the 50 percent expansion limit has been removed; and an additional test option allowing for the use of a sieve test gauge for testing multiple water beads has been added. Corresponding changes have been made to the test method to reflect these changes.
- In section 1250.4(c)(2), the extractable acrylamide limit has been changed from 65 µg to 325 µg per 100 small water beads or per 1 large water bead.
- In section 1250.4(c)(2), the proposed definitions for small and large water beads describing acrylamide testing, have been changed from “across the smallest diameter” to “in all dimensions” for small water beads, and from “across the smallest diameter” to “in any dimension” for large water beads in the final rule.
- In section 1250.4(d), Figures 3 (“Warning for Water Bead Toys and Packaging”) and 4 (“Toys That Contain Water Beads”) of the proposed rule have been renumbered in the final rule as Figures 4 and 5, respectively, and the figure captions have been revised for clarity. The Figure 4 caption now reads, “Warning for Water Bead Toys and their Packaging,” and the Figure 5 caption now reads, “Warning for Toys with Contained Water Beads and their Packaging.” In addition, both figures have been revised to reflect changes in warning content made in response to public comments and other clarifications. All changes described below apply to both figures unless otherwise specified.

- The first sentence of each warning has been changed from “This product contains water beads that grow larger,” to “Contains water beads that can grow larger when swallowed or inserted in the ear or nose.”
- The sentence, “Discard if beads are coming out,” in Figure 4 of the proposed rule, has been changed to, “Discard product if beads start to come out,” and this revised sentence has been moved into the bullet list of precautionary statements in Figure 5 (renumbered from Figure 4) of the final rule.
- The sentence, “Children have DIED after swallowing water beads because the beads blocked their intestines,” has been changed to “Children have DIED when the beads blocked their intestines.”
- The sentence, “Your child can die too,” has been deleted.
- The sentence, “Inserted beads have resulted in surgeries,” has been added to the warnings.
- The sentence, “Watch older children during use,” has been added to the warning after the statement about keeping water beads away from babies and toddlers.
- The sentence, “Never use as a sensory toy or bath toy,” has been deleted.
- The sentence, “Seek immediate medical attention if you think your child swallowed beads or inserted beads into their nose, ears, or other part of the body,” has been changed to, “Get medical help right away if you think your child swallowed or inserted beads.” The phrase, “Get medical help right away,” has also been highlighted using boldface type.
- In section 1250.4(d)(1)(vi)(C), the language “section X of” has been deleted and missing quotation marks have been added at the beginning of the phrase “safety white.”

For the reasons explained in this preamble, the Commission determines that the water bead toy requirements comply with section 106 of the CPSIA because they are more stringent than the current requirements in ASTM F963–23 and would further reduce the risk of injury and death associated with products within the scope of the rule, and they would provide the highest level of safety that is feasible for such products.

II. The Product

A. Description of the Product

Water beads are various shaped, multi-colored or clear beads composed of liquid absorbing polymers, such as, but not limited to, polyacrylamides and polyacrylates, which expand when soaked in liquid such as water. When first purchased, water beads are small and dehydrated, typically no larger than 7.0 mm diameter. Water beads are often sold in large quantity packages that may contain up to thousands of beads (depending on original size) in one package. While in the dehydrated state, with all water content removed, water beads are typically either hard, solid beads, or soft-gelled beads. Water beads are designed to be soaked in liquid such as water, which allows the beads to absorb the liquid and expand. After being soaked in liquid for periods as short as a few hours for smaller water beads or two to three days for larger water beads, water beads increase in size, as demonstrated in Figure 1. Some water beads can expand, for example, from 2.0 mm diameter in their dehydrated state to 16.0 mm diameter when fully expanded (shown on the left in Figure 1), or from 7.0 mm diameter in the dehydrated state to 50.0 mm diameter when fully expanded (shown on the right in Figure 1). Thus, water beads have the potential to expand up to 800 percent of their original diameter. Once expanded, water beads remain moist even if removed from water but do not appear to have any adhesive properties that would cause them to stick together. When broken apart by hand or squeezing, expanded water beads tend to break into small, fragmented pieces (shown in Figure 2).

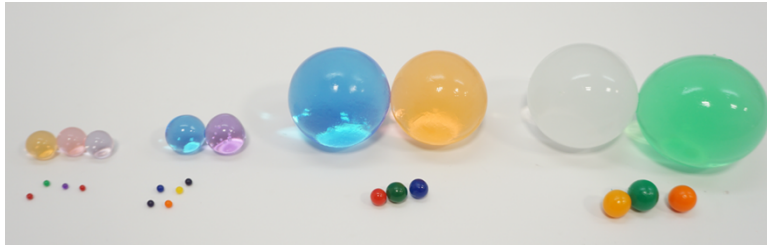

Figure 1: Water Beads, Before and After Expansion.



Figure 2: Water Beads, After Being Squeezed and Breaking.

Water bead toys are often sold in bulk or as part of other children’s toys, such as experiment kits and sensory kits, or can be contained within toy squeeze balls or stress balls. Some water beads products are not marketed as children’s toys and are outside of the scope of this rule.

As noted above, CPSC currently regulates water bead toys under section 4.40 of ASTM F963–23, *Expanding Materials*, and 16 CFR 1250.2(a). ASTM F963–23 does not define the term “water bead,” but it defines an “Expanding Material” in section 3.1.28 as “any material used in a toy which expands greater than 50 percent in any dimension from its as-received state when tested in accordance with 8.30.” Section 8.30 directs that the toy must be submerged in deionized water maintained at 37 °C +/- 2 °C for a duration of 72 hours, with the toy dimensions measured at 6-, 24-, 48-, and 72-hour intervals in order to determine if the toy is an expanding material. This final rule defines “water bead” under part 1250 as “a various shaped liquid absorbent polymer, composed of materials such as, but not limited to, polyacrylamide and polyacrylate, which expands when soaked in liquid.” The final rule’s test procedures incorporate ASTM’s process for conditioning water bead toys.

B. Scope of Products Subject to the Rule

This rule applies to both water bead toys and toys that contain water beads. A toy is “any object designed, manufactured, or marketed as a plaything for children under 14 years of age.” 16 CFR 1250.2(a); section 3.1.92 of ASTM F963–23. Water bead toys, therefore, are water beads designed, manufactured, or marketed as a plaything for children under 14 years of age (consistent with the definition of “toy” in 16 CFR 1250.2(a)), while toys that contain water beads are toys that encompass water beads within the toy and the water beads are not intended to be accessed, such as a squeeze ball (Figure 5). Commonly, water beads are included in a variety of toy products, such as toy experiment kits (Figure 3), toy sensory kits (Figure 4), toy squeeze/sensory balls filled with water beads (Figure 5), and water bead toy guns designed to shoot water bead projectiles (Figure 6). Each product would be subject to the rule and would need to meet the requirements of the rule.



Figure 3: Toy Experiment Kit.



Figure 4: Toy Sensory Kit.



Figure 5: Toy Squeeze/Sensory Ball.



Figure 6: Water Bead Toy Gun.

Examples of products outside of the scope of this rule are water beads that are not toys or are not contained in toys and are for various non-toy uses, such as water beads used for decorative purposes (*e.g.*, placement in candle holders), in vases or gardens for plant hydration, as air freshener products or deodorizers for cat litter, and in first-aid cold packs.

III. Incident Data and Hazard Patterns

Staff searched two CPSC-maintained databases to identify incidents and hazard patterns associated with water beads: the Consumer Product Safety Risk Management System

(CPSRMS)⁵ and the National Electronic Injury Surveillance System (NEISS).^{6,7} Due to data availability, the CPSRMS incidents occurred between January 1, 2017, and December 31, 2023, while the NEISS incidents occurred between January 1, 2017, and December 31, 2022. The incident data and hazard patterns cited in support of the NPR support this final rule and are unchanged from the NPR. For further discussion of the incident data and hazard patterns, see the preamble of the NPR (89 FR at 73031), which describes the incident and hazard patterns associated with water bead toys in further detail.

A. CPSRMS Data

Staff identified 64 incidents in CPSRMS from 2017 through 2023 associated with the use of water bead toys. Staff identified the following incident data hazard patterns associated with water bead toys: ingestion, ear insertion, nose insertion, aspiration, and choking. The CPSRMS incident data relied upon for the rule is unchanged from the NPR.

B. National Injury Estimates from NEISS

Based on NEISS data, staff estimates 6,300 injuries (sample size = 250, coefficient of variation = 0.27) related to water beads were treated in U.S. hospital EDs over the six-year

⁵ CPSRMS includes data primarily from three groups of sources: incident reports, death certificates, and in-depth follow-up investigation reports. A large portion of CPSRMS consists of incident reports from consumer complaints, media reports, medical examiner or coroner reports, retailer or manufacturer reports (incident reports received from a retailer or manufacturer involving a product they sell or make), safety advocacy groups, law firms, and federal, state, or local authorities, among others. It also contains death certificates that CPSC purchases from all 50 states, based on selected external cause of death codes (ICD-10). The third major component of CPSRMS is the collection of in-depth follow-up investigation reports. Based on the incident reports, death certificates, or NEISS injury reports, CPSC field staff conduct in-depth investigations (on-site, telephone, or online) of incidents, deaths, and injuries, which are then stored in CPSRMS.

⁶ NEISS is the source of the injury estimates; it is a statistically valid injury surveillance system. NEISS injury data are gathered from emergency departments of a sample of hospitals, with 24-hour emergency departments and at least six beds, selected as a probability sample of all U.S. hospitals. The surveillance data gathered from the sample hospitals enable CPSC to make timely national estimates of the number of injuries associated with specific consumer products.

⁷ Staff performed multiple searches consisting of a combination of product codes and narrative or manufacturer/model keyword searches to find water bead incidents. Staff extracted data coded under 1381 (Toys, not elsewhere classified), 1395 (Toys, not specified), 1413 (Greenhouse supplies or gardening supplies [excluding plant stands, tools, hoses, sprayers and chemicals]), 1616 (Jewelry [excluding watches]), 1682 (Hair curlers, curling irons, clips & hairpins), 5016 (Balls, other or not specified), 5020 (Pretend electronics, tools, housewares, and appliances), 9101 (No clerical coding - retailer report), and 9102 (No clerical coding - retailer report).

period from 2017 through 2022.⁸ Of the 250 sample NEISS cases, none were fatal. The NEISS incident data relied upon for the rule is unchanged from the NPR.

C. Overview of Hazards in Relation to Child Supervision and Behavior

Water bead ingestion, nasal and ear insertion, choking, and aspiration can occur in seconds. Many incidents are not witnessed because the caregiver was not directly looking at the child when the ingestion, insertion, choking, or aspiration occurred. Research indicates that toddlers and preschoolers (ages 2 years old through 5 years old) are out of view of a supervisor for about 20 percent of their awake time at home and are not within visual or hearing range for about 4 percent of awake time at home.⁹ A study of 100 parents found that the mean amount of time parents were willing to leave a child unsupervised in low-risk areas, such as a living room, was six minutes before the child was old enough to crawl and four minutes after the child was old enough to crawl but before the child was 2 years old.¹⁰ Consumers reasonably may be unaware that water bead toys are hazardous, particularly because they are marketed for children's play.

Research demonstrates that infants and toddlers are likely to mouth objects within reach. Mouthing non-food items is a normal part of children's exploratory behavior that contributes to incidents of choking and poisoning.¹¹ This behavior is part of the reason for the ban on small parts for toys intended for children younger than 3 years of age, for example, and the mandatory small-parts warning for toys and games intended for children ages 3 years old to 6 years old. 16 CFR part 1501. Mouthing non-food items tends to decrease as a child's age increases; however,

⁸ The estimated injuries for this final rule are less than the estimate presented in the public guidance on water beads that can be found on the Commission's website at www.cpsc.gov/Safety-Education/Safety-Education-Centers/Water-Beads-Information-Center. The difference is mainly due to excluding incidents with hazard patterns related to rashes or other allergic reactions and incidents involving water bead gel blaster projectiles, which commonly involve eye injury and some of which may not involve children's toys in the scope of this rule.

⁹ Morrongiello, B. A., Corbett, M., McCourt, M., & Johnston, N. (2006). Understanding unintentional injury-risk in young children I. The nature and scope of caregiver supervision of children at home. *Journal of Pediatric Psychology*, 31(6): 529–539.

¹⁰ Garzon, D.L., Lee, Dr. R.K., and Homan, S.M. (2007) "There's No Place Like Home: A Preliminary Study of Toddler Unintentional Injury." *Journal of Pediatric Nursing*, 22, 368 – 375.

¹¹ Tulve, N., Suggs, J., McCurdy, T., Cohen-Hubal, E., & Moya, J. (2002). Frequency of mouthing behavior in young children. *Journal of Exposure Analysis and Environmental Epidemiology*. 12, 259 – 264.

it is not uncommon for children over the age of 3 years old to experience choking or ingestion episodes with objects other than food.¹² Children are prone to ingest or insert small, smooth, colorful objects, like water beads or toy parts.¹³ Unintentional foreign body ingestion is a leading cause of nonfatal emergency department (ED) visits in children younger than 9 years old.¹⁴ Management and treatment for childhood accidental ingestion is well documented in pediatric medical literature.¹⁵

D. Recalls

From December 2012 through March 2024, the Commission's Office of Compliance and Field Operations conducted five recalls and issued two unilateral press release warnings regarding water bead toy products. The announcements involved one death and five reported injuries and affected approximately 166,000 units. There have been no additional recalls of water bead toy products since the publication of the NPR. See the preamble of the NPR for additional details about the above recalls.

IV. Review of Voluntary Standards – ASTM F963 and EN 71-1

A. Background

ASTM F963 includes performance requirements and test methods for toys, as well as requirements for warning labels and instructional literature, to reduce or prevent injury to

¹² A-Kader. (2010) Foreign body ingestion: children like to put objects in their mouth. *World J Pediatrics*, Vol 6 No 4. November 15, 2010. www.wjpcp.com; Orsagh-Yentis D, McAdams RJ, Roberts KJ, et al. (2019). Foreign-Body Ingestions of Young Children Treated in US Emergency Departments: 1995–2015. *Pediatrics*. 143(5):e20181988; Reilly, J. (1992, Fall). Airway Foreign Bodies: Update and Analysis. *Int Anesthesiol Clin*.30(4):49-55; Altman, A., Ozanne-Smith, J. (1997). Non-fatal asphyxiation and foreign body ingestion in children 0-14 years. *Injury Prevention*. 3:176-182.

¹³ Svider, P.F., Vong, A., Sheyn, A., Bojrab, D.I., Hong, R. S., Eloy, J.A., and Folbe, A.J. (2015). What are we putting in our ears? A consumer product analysis of aural foreign bodies. *The Laryngoscope*. 125, 709-714; Heim, S.W., & Maughan, K.L. (2007). Foreign Bodies in the ear, nose, and throat. *American Academy of Family Physicians*, 76, p.1186-1189.

¹⁴ Centers for Disease Control and Prevention. Web-based Injury Statistics Query and Reporting System (WISQARS) [Online]. (2003). National Center for Injury Prevention and Control, Centers for Disease Control and Prevention. Available from: URL: www.cdc.gov/ncipc/wisqars. [10/1/2022].

¹⁵ Kay, M., & Wyllie, R. (2005). Pediatric foreign bodies and their management. 7(3):212-8; Lee, J.H., (2018) Foreign Body Ingestion in Children. *Clinical Endoscopy*, 51:129-136; Kramer et al., 2015; Connors GP, & Mohseni M. Pediatric Foreign Body Ingestion. [Updated 2021 Jul 18]. In: StatPearls [Internet]. Treasure Island (FL): StatPearls Publishing; 2022 Jan-. Available from: <https://www.ncbi.nlm.nih.gov/books/NBK430915/> - (accessed 4/12/22) Pediatric Foreign Body Ingestion - StatPearls - NCBI Bookshelf (nih.gov).

children or death of children from mechanical, chemical, and other hazards associated with toy use. Toys must comply with this standard pursuant to 16 CFR part 1250.

ASTM F963 defines “expanding material” as “any material used in a toy which expands greater than 50% in any dimension from its as-received state.” Section 4.40 of ASTM F963–23 addresses potential hazards associated with expanding materials by requiring that toys, and removable components of toys, that are composed of expanding materials and fit entirely within the small parts cylinder (16 CFR part 1501) while in the toy’s as-received size condition, must, after expansion, completely pass through a 20.0 mm diameter gauge while a force of up to 4.5 lbf (pound-force) is applied.

Water beads that expand up to 20.0 mm diameter would meet the ASTM F963–23 expanding materials requirements because they would pass through the gauge, but water beads that expand larger than 20.0 mm diameter would likely fail the requirements because the water beads would not pass through the gauge. Incident data show that water beads that expand to a size larger than 20.0 mm diameter are hazardous, but many water beads that expand to a size smaller than 20.0 mm and would pass the ASTM F963-23 test are also hazardous, as explained in section III of this preamble.

Another voluntary standard used primarily in the European Union, EN 71-1, *Safety of Toys – Part 1: Mechanical and Physical Properties*, also provides requirements for expanding materials. Section 3.24 of EN 71-1 defines an “expanding material” as a “material, the volume of which expands when exposed to water.” Section 4.6 of EN 71-1 establishes performance requirements for expanding materials in toys or components of toys which fit entirely in a 31.7 mm diameter small parts cylinder, the same size as the small parts cylinder from 16 CFR part 1501, and states they shall not expand more than 50 percent in any dimension when measured after being submerged in demineralized water for 24, 48, and 72 hours. If the expansion in any dimension is more than 50 percent, then the toy does not comply with the expanding material requirement. For example, water beads with an unexpanded diameter of 2.0 mm and that expand

larger than 3.0 mm diameter would pass through the small parts cylinder in their dehydrated state but expand by more than 50 percent, thus failing the EN 71-1 requirements. Additionally, EN 71-9, *Safety of Toys – Part 9: Organic Chemical Compounds - Requirement*¹⁶ provides a test method and a concentration limit for acrylamide, a hazardous chemical found in toys.

Acrylamide limitations in EN 71-9 were developed to address acrylamide exposure following long-term licking, sucking, and chewing of toys that are intended to be mouthed for a significant amount of time, such as teething rings and rattles. In contrast, water bead toys addressed in this rule are not intended to be mouthed for a significant amount of time. This rule is intended to address ingestion, insertion, choking, and aspiration hazards, not mouthing. Therefore, this rule mandates a different acrylamide limit and test method, intended to address the hazards discussed in section V of the NPR preamble.

B. Assessment of Current ASTM F963–23 Performance Requirements

The test method for expanding materials described in section 8.30, *Expanding Materials – Test Method* of ASTM F963–23, requires that an expanding material, such as a water bead, first be submerged in deionized water for up to 72 hours in order to reach its largest expanded size. The product is then tested to determine whether, at its largest expanded size, the water bead can pass through a gauge with a 20.0 mm (+0.0/-0.1 mm) diameter hole, when a force of 4.5 lbf (pound-force) is applied to the water bead in the direction of the hole via a rod having a hemispherical end diameter of 10.0 mm.

Staff assessed the current ASTM test method in section 8.30 of ASTM F963–23 and found that using a rod to apply force to an expanded water bead to determine whether the water bead can fit through a test gauge does not realistically represent the compression forces exerted by the body on a water bead when it is swallowed. The use of a 10.0 mm diameter rod to apply a force when conducting the test generally causes fragmentation of the water bead (Figure 7),

¹⁶ EN 71-9 provides requirements and test methods for organic chemical compounds, such as acrylamide. Previously cited EN 71-1 provides requirements and test methods for mechanical and physical properties, such as expansion limits. Both are part of the standard EN 71.

which would be considered a “pass” pursuant to the ASTM test standard. However, incident data shows water beads remain whole after being swallowed, thus creating a gastrointestinal tract blockage.¹⁷ Because the force that the rod exerts can damage the expanded water bead and cause fragmentation, staff have assessed that the current ASTM test method is inadequate to effectively test water beads for an ingestion and blockage hazard.

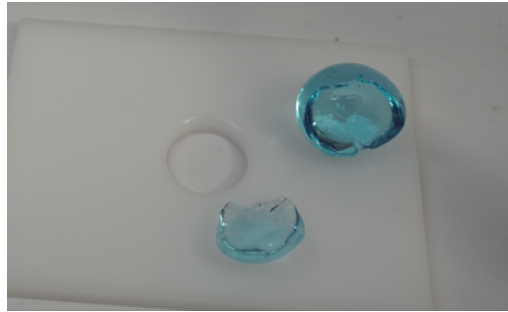

Figure 7: Expanded Water Bead After Being Fragmented by 10.0 mm Diameter Rod End.

Staff also analyzed the 20.0 mm (+0.0/-0.1 mm) diameter gauge specified in section 4.40 of ASTM F963–23 and determined that, in light of incident data demonstrating how ingestion hazards occur, the gauge diameter size should be reduced. The 20.0 mm diameter gauge used in ASTM F963 was selected based on the dimension of the pyloric sphincter¹⁸ within the gastrointestinal tract of an 18-month-old child, because at the time the ASTM F963 expanding materials requirements were created, the pyloric sphincter was thought by the drafters to be the most likely site where a gastrointestinal blockage would occur. As explained below, objects that can cause a gastrointestinal blockage are more likely to cause a blockage at either the gastric outlet part of the stomach or the ileocecal valve at the end of the small intestine.¹⁹

Water beads, like other foreign bodies and food, do not remain in the stomach for long. Therefore, water beads generally do not expand fully in the stomach but pass through the pyloric sphincter and into the small intestine. Water beads continue to expand in the small intestine,

¹⁷ Examples include the following IDIs: 230727CBB1846, 230707CBB1698, 230613CBB1591, 170802CCC3140 and 221107CFE0002.

¹⁸ The pyloric sphincter is the valve located at the bottom of the stomach which opens to allow food to pass from stomach to the small intestine.

¹⁹ The ileocecal valve is a sphincter muscle situated at the junction of the ileum (last portion of the small intestine) and the colon (first portion of the large intestine).

where they spend more time and are exposed to liquid that facilitates expansion. After the water beads expand fully in the small intestine, they are unable to pass through the ileocecal valve and into the large intestine, therefore causing a gastrointestinal blockage. Staff evaluated the relevant recent incident data and concluded that because the ileocecal valve is often the site of a gastrointestinal blockage when a child ingests a water bead, the ileocecal valve is a more appropriate anatomical structure on which to base the diameter of the test gauge than the pyloric sphincter. Literature on ileocecal valve size indicates valve size will vary based on age and natural variation within the population,^{20, 21} but the Commission has not identified reliable authorities providing ileocecal valve sizes for children between the ages of 9 months old and 3 years old. Accordingly, as explained in section V of the preamble of the NPR (89 FR 73035), the Commission has based the diameter size of the test gauge through which water bead toys must pass on incident data.

Section 4.40 of ASTM F963–23 also requires that “[t]oys, and removable components of toys, which fit entirely inside the small parts cylinder in their as-received condition, and which are composed of an expanding material, shall completely pass through the gauge when tested.” The referenced small parts cylinder is from 16 CFR 1501.4, referenced section 4.6, *Small Objects*, of ASTM F963–23, which provides general safety requirements. Under section 4.6.1, toys intended for children under 36 months of age, “including removable [components], liberated components, or fragments of toys[,] shall [not] be small enough without being compressed to fit entirely within [the small parts cylinder].” This requirement is intended to minimize choking, ingestion, or inhalation hazards. Most water bead toy products are intended for children older than 36 months of age and therefore are not required to comply with the small objects requirements in section 4.6 of ASTM F963–23.

²⁰ Tang SJ, Wu R. Ileocecum: A Comprehensive Review. *Can J Gastroenterol Hepatol*. 2019 Feb 3;2019:1451835. doi: 10.1155/2019/1451835. PMID: 30854348; PMCID: PMC6378086.

²¹ Silva AC, Beaty SD, Hara AK, Fletcher JG, Fidler JL, Menias CO, Johnson CD. Spectrum of normal and abnormal CT appearances of the ileocecal valve and cecum with endoscopic and surgical correlation. *Radiographics*. 2007 Jul-Aug;27(4):1039-54. doi: 10.1148/rg.274065164. PMID: 17620466.

Finally, to address the potential presence of toxic chemicals in toys, section 4.3, *Toxicology* of ASTM F963–23 requires that all toys must comply with the Federal Hazardous Substances Act (FHSA) toxicity and hazardous substances standards. Although there is a generalized FHSA compliance requirement for all of ASTM F963–23, section 4.40, *Expanding Materials* of ASTM F963–23 does not specifically mandate testing for hazardous chemicals in expanding materials. Water beads are composed of absorbent polymers, which can contain acrylamide monomer—a chemical that can be hazardous when ingested.²² ASTM F963–23 does not have a limit or a test method for acrylamide monomer in water bead toys. Therefore, the current ASTM standard is inadequate to provide the highest level of safety feasible to ensure that the chemicals in water bead toys are non-toxic. Because water bead toys containing high levels of acrylamide monomer are toxic, the rule establishes content limits and test methods to address the toxicity hazard presented by acrylamide.

C. Assessment of Current ASTM F963–23 Labeling Requirements

Section 5.0 of ASTM F963–23, *Labeling Requirements* contains general labeling requirements that apply to toys, including water bead toys or toys containing water beads. However, the requirements in section 5.0 are not specifically referenced in section 4.40, *Expanding Materials*. Only broad warning statements for small part choking hazards and small ball hazards are required for expanding materials. While the warning statements address general choking hazards, they do not address or inform about injuries (*e.g.*, gastrointestinal blockage) or deaths that have occurred when water bead toys expand after being swallowed or inserted. The primary U.S. voluntary consensus standard for product safety signs and labels, ANSI Z535.4, *Product Safety Signs and Labels*, and other literature and guidelines on warnings, consistently recommend that warnings include information about the consequences of exposure to the hazard.

²² Per the Federal Hazardous Substances Act (FHSA) (16 CFR 1500.3(c)(2)(i)(A)), a substance with a median lethal dose (LD₅₀) between 50 and 5000 mg/kg in rats is “toxic” for acute toxicity. The reported oral LD₅₀ values for undiluted acrylamide in rats range from 150 to 413 mg/kg. See ATSDR *Toxicological Profile for Acrylamide*, available at <https://www.atsdr.cdc.gov/ToxProfiles/tp203.pdf>.

Warnings research has shown that providing explicit information about the consequences of a hazard can increase perceived hazardousness, which has been shown to increase warning effectiveness.²³

D. 2024 Proposed Draft Revisions to ASTM F963

On January 22, 2024, and March 25, 2024, staff met with the ASTM F15.22 Emerging Hazards Task Group to discuss a possible revision of ASTM F963 to include specific requirements for water bead toys. As explained in the preamble of the NPR (89 FR 73037), staff and ASTM discussed incident information and the ASTM 20.0 mm diameter test gauge compared to CPSC’s proposed funnel test gauge. On July 9, 2024, ASTM shared a draft proposal to revise section 4.40 of ASTM F963–23 to include water bead toy-specific requirements. On July 18, 2024, ASTM submitted a ballot for a vote on the proposal, which was available until August 19, 2024.

Staff reviewed the 2024 draft proposal, finding it inadequate to address all known water bead toy hazards. In the draft proposal, water bead would be defined as a “spherical or spheroid water-absorbent object, intended to expand in size when immersed in a liquid.” This draft revision would apply to water bead toys intended to be accessible in dehydrated state and water bead toys in the expanded state. If the water bead toy is already expanded, the water bead toy would be given time to dehydrate before testing. These draft requirements would not apply to water bead toys that are not intended to be accessible, such as water beads within a squeeze ball.

ASTM’s draft performance test proposal would require first measuring the diameter of a dehydrated water bead toy and then measuring the maximum amount of expansion after soaking the water bead in deionized water at 37 °C. If the maximum expansion is greater than 50 percent in diameter, then the water bead toy will be placed in the funnel test gauge to determine whether it can pass through the gauge under a certain external pressure. If the maximum expansion of the

²³ Laughery, Sr., K. R., & Smith, D. P. (2006). Explicit Information in Warnings. In M. S. Wogalter (Ed.), *Handbook of Warnings* (pp. 419–428). Mahwah, NJ: Lawrence Erlbaum Associates.

water bead toy is less than or equal to 50 percent in diameter, no further testing is required. Based on incident data, the ASTM draft proposed use of a funnel test gauge with a 12.0 mm diameter (+0.0/-0.1 mm) as a performance requirement. When attempting to pass an expanded water bead toy, the proposed test includes applying a force of 0.1 lbf to the water bead toy in the direction of the 12.0 mm diameter hole using a 10.0 mm diameter rod having a flat end. The ASTM draft stated that “a water bead material which breaks or loses integrity during this test is considered to be acceptable,” and therefore if the fragmented pieces pass through the funnel test gauge, the product would still meet the draft requirement even if the unbroken water bead toy was larger than 12.0 mm. The draft did not include acrylamide limits or revised labeling requirements.

Staff reviewed the draft ASTM proposal and found that a gauge size diameter of 12.0 mm is inadequate to address known hazards from water bead toys. The draft proposed 12.0 mm diameter is based on one incident,²⁴ which describes a 13-month-old female who was unable to pass through her body a water bead toy presumed to be as small as 13.0 mm diameter. However, while staff knows based on the incident a 13.0 mm diameter water bead toy can cause a blockage in a child, this incident by itself does not establish the size of the largest water bead toy that can safely pass. Further, the draft ASTM requirements would not require testing for a dehydrated water bead toy of 13.0 mm diameter, which is capable of expanding to 19.5 mm diameter, because the water bead toy would not have expanded to more than 50 percent of its original size. As explained in section IV.B of this preamble, fragmentation of the water bead toy during testing is not representative of incident data, and as explained in section V.C.1 of the NPR preamble, testing of water beads contained within toys, such as squeeze balls, is necessary to address incidents of children biting into a squeeze ball and swallowing the water beads within.²⁵

²⁴ IDI 170802CCC3140.

²⁵ Such as incident 20230601–3657B–2147347238 found on *saferproducts.gov*. A 2-year-old child bit into a stress ball and swallowed the contents requiring medical treatment. The consumer claims to have been unaware that there were water beads inside.

Therefore, while the draft ASTM proposal may be an improvement on the current ASTM F963 expanding materials requirements, it would not adequately address known water bead hazards, even if adopted.

Since publication of the NPR on September 9, 2024, the subcommittee held meetings on January 15, 2025, and February 10, 2025, to discuss the negative votes on the proposed ballot and what modifications should be made. Two additional task groups have been formed: one task group for discussing potential sampling sizes for water bead toy testing and the other task group for discussing potential warning label requirements. The task group discussing sampling size met on March 13, 2025, May 28, 2025, and August 5, 2025. The task group discussing warning label requirements met on April 2, 2025.

E. Assessment of Current EN 71-1 Expanding Materials Requirements

The test method for expanding materials described in section 8.14 of EN 71-1 requires that an expanding material, such as a water bead toy, that fits entirely in a small parts cylinder first be measured, using calipers,²⁶ to determine its original size in each dimension. Next, the expanding material must be submerged in demineralized water for up to 72 hours to reach its largest expansion size. After expansion, the water bead toy must be measured again to determine if it has expanded more than 50 percent of its original size in any dimension. If the water bead toy has expanded more than 50 percent, then it fails the expanding material requirements.

The Commission determines that the current EN 71-1 expanding material requirement is inadequate as a stand-alone requirement. For example, staff assessed that a maximum size requirement is necessary because the EN 71-1 standard would permit a water bead toy having a dehydrated diameter of 9.0 mm to expand to 13.5 mm diameter. While this expansion would not be more than 50 percent of the water bead's original size and compliant with the EN 71-1 expanding material requirements, the expanded water bead would likely cause a gastrointestinal blockage if a child ingested it. Indeed, as described in section III of the preamble of the NPR (89

²⁶ An instrument used to measure certain dimensions of an object.

FR 73028), a water bead with 13.0 mm diameter is known to have caused a gastrointestinal block in a 13-month-old female. If the only requirement on water beads is that they do not expand to more than 50 percent of the original size, the ingestion hazard would still be present.

V. Response to Public Comments

CPSC received 135 public comments during the NPR comment period. The comments are available on www.regulations.gov, by searching under docket number CPSC-2024-0027. This section describes the significant issues raised in the comments and CPSC's responses to them. Commenters include two gel blaster manufacturers, That Water Bead Lady, the Toy Association, Alan Kaufman, China World Trade Organization/Trade Barriers to Trade, two third party laboratories, consumer advocacy groups, pediatric gastroenterologists and surgeons, daycare workers, parents, and a class of law students.

A. General

1. Scope

Comment: Gel Blaster Inc., SplatRball, and Michael Ravnitzky suggest water bead guns marketed towards adults and used in activities like paintball or airsoft should not be considered children's toys. Instead, they belong in the sporting goods and recreational equipment category. Two of these commenters, Gel Blaster Inc. and SplatRball, argue that water bead guns are not consistent with the types of projectile toys identified in CPSC's 2020 Age Determination Guidelines as being intended for children 9 through 12 years old. Connor Mitchell expressed concern about limiting the rule to toys, because he believes water bead guns are intended for ages 14 and older, and therefore would fall outside the scope of the rule. Albert Tacornal states that more advanced water bead guns should not be subject to the rule and asserts that most water bead guns are marketed to children under age 14 based on their quirky designs and colorful patterns. American Academy of Pediatrics (AAP) suggest all water bead guns marketed to children should be in scope of the rule.

Response: Water bead guns that are designed, manufactured, and marketed to adults (*i.e.*, marketed for ages 14+ years old) for use in activities similar to paintball or air soft are outside the scope of this rule because they are not toys as defined by ASTM F963. However, some water bead guns are designed, manufactured, or marketed for children younger than age 14, as indicated by commenters, and these products are within the scope of the rule and subject to its requirements. Although some commenters note that water beads differ from other types of air-propelled projectiles intended for children 9 through 12 years old, they also acknowledge that water beads are not “penetrating” projectiles of the type identified by the CPSC 2020 Age Determination Guidelines as being inappropriate for this age group. As noted earlier, some water bead guns are designed, manufactured, or marketed for children who are young enough for these products to be within the scope of the rule. In addition, if water beads used as projectiles were not appropriate for children up to age 12, there could still be some water bead guns (*e.g.*, those designed, manufactured, or marketed for children as young as age 13) that fall within the scope of the rule.

Comment: Consumer Reports asserts that manufacturers and retailers of water beads that were previously marketed as toys or for use by children may attempt to evade the proposed rule by re-marketing their products for other uses such as decorative or agricultural purposes. If these repurposed and remarketed water bead products continue to include images of children and other fun descriptive language, it could be mistaken by a caregiver as a product suitable for use by children.

Response: CPSC assesses product packaging and marketing materials to determine whether certain water bead products are marketed for ages 14+ years old, and therefore, would not be within the scope of this rule. If CPSC finds water bead products that include images of children and other fun descriptive language, CPSC may determine those water bead products are toys within scope of the rule.

Comment: Jacob Lowe states that a ban on all toys that use acrylamide and are likely to be orally inserted would be reasonable.

Response: This comment is outside of the scope of the rulemaking. However, if the Commission finds evidence of hazards presented by acrylamide in toys other than water bead toys in the future, then regulatory activity may be considered.

2. Definitions

Comment: Brianna Zimmerman, Jared Shelton, and Christian Beasley suggest modifications to the definition of water bead, such as replacing the term “water” within the definition, with the term “liquid” or “water-based liquid” because while water is an appropriate term, it may be too narrow. Similarly, AAP and Consumer Federation of America (CFA) suggest modifications to the definition of water bead, such as not limiting the definition to only “water” but instead including “water and other fluids” that can be absorbed.

Response: Based on these comments, the language in the definition of water bead in section 1250.4(b) in the final rule has been amended from “water absorbent polymer” to “liquid absorbent polymer.” This change to the broader term “liquid” is intended to include within the definition water bead, water beads that can potentially absorb liquids other than water that could potentially present the same risk of injury. Thus, the amended definition of water bead in section 1250.4(b) of the final rule reads “a various shaped liquid absorbent polymer, composed of materials such as, but not limited to, polyacrylamide and polyacrylate, which expands when soaked in liquid.”

Comment: Emily Threatt contends the scope of the regulation should explicitly cover toys that are not commonly called “water beads,” because water beads are not the only water absorbent polymer toys that are hazardous. Other water absorbent polymer toys pose a hazard as well, specifically, those in a non-uniform shape.

Response: The commenter’s assertion that the definition of “water bead” in the rule does not cover other products that are not commonly called water beads and other water absorbent

polymer toys, such as those in non-uniform shape, is incorrect. As defined in the rule, a water bead is a “various shaped liquid absorbent polymer.” Therefore, the definition does include the examples noted by the commenter, including those with a non-uniform shape.

Comment: Michael Ravnitzky states the definition of water beads could be expanded to include specific examples of polymers and their chemical compositions. This would help in clearly identifying what constitutes a water bead and avoid ambiguity.

Response: The definition of water bead in the rule states that they are an “absorbent polymer, such as, but not limited to, polyacrylamide and polyacrylate...” Therefore, it is unnecessary to include specific examples of other polymers or their chemical compositions because the phrases “such as” and “not limited to” in the definition indicate that various types of polymers and their chemical compositions fall within the definition of water bead and thus are not limited to just polyacrylamide and polyacrylate. Additionally, any such list of specific examples of polymers and their chemical compositions would necessarily be incomplete and only cover certain examples.

Comment: Gel Blaster Inc. suggests the water bead definition should specify polymers to only include polyacrylamides or polyacrylates and to avoid bundling in natural polymers like starch and cellulose. The commenter asserts that there is no evidence that there are currently water beads on the market that are not polyacrylamides or polyacrylates that have been involved in ingestion issues.

Response: While there is currently no incident data involving water beads that are not made of polyacrylamides or polyacrylates, natural polymers such as starch and cellulose expand just like polyacrylamides and polyacrylates, thus presenting the same hazards from expansion as other types of polymers. The use of the term “polymer” in the definition of water bead is inclusive of natural polymers such as starch and cellulose and the language is clear, as it is not intended to include only polyacrylamides or polyacrylates, as noted by the use of “such as” after

“polymer.” Therefore, the Commission declines to explicitly exclude natural polymers such as starch and cellulose from the definition of water bead in the rule.

Comment: Christian Beasley asserts that the term “soaked” is too constrictive for the proposed definition and the amount of fluid necessary for a water bead to expand. Even though “soaked” accurately represents that the water bead expands if it is immersed in water or other water-based fluid, it is too narrow as it implies that the water bead must be immersed in something to expand. The commenter states that the more appropriate term would be “exposed” because, by definition, “exposed” means “open to view, not shielded or protected.” Therefore, the proposed definition should be altered to define a water bead as “various shaped water absorbent polymers, composed of materials such as, but not limited to, polyacrylamides and polyacrylates, which expand when exposed to water or water-based fluid.”

Response: The term “exposed” is an inaccurate word because a water bead will not noticeably expand if only a drop of water is placed on the water bead (*e.g.*, the water bead is exposed to a drop of water). The water bead must be soaked in water for a lengthy period to expand, and thus potentially present a hazard. Therefore, the Commission declines to make the commenters recommended change to replace “soaked in water” with “exposed to water” in the definition of water bead.

Comment: The Toy Association contends the proposed definition of water bead is missing the parameter for expansion that is used for the defined term ‘expanding materials’ in ASTM F963.²⁷ Without reference to the term ‘expanding materials,’ the commenter asserts that the proposed definition conflicts with established and commonly applied definitions for all expanding materials (in addition to the NPR proposal requiring that the water bead does not expand in a manner consistent with expanding materials, which is more than 50 percent its original size).

²⁷ ASTM F963 section 3.1.28: expanded material means “any material used in a toy which expands greater than 50% in any dimension from its as-received state.”

Response: It is unnecessary for the definition of water bead in the rule to reference the definition of “expanding materials” from ASTM F963-23. By removing the 50 percent expansion limit from the final rule, for the reasons described below in the mechanical requirements section, water beads can still be classified as an expanding material because they will grow more than 50 percent of their original size. Finally, the definition and requirements for water beads in this rule will be a subsection to the currently existing general “expanding materials” requirements in section 4.40 of ASTM F963-23.

3. Color of Water Beads

Comment: Elenor Grundberg, Brianna Zimmerman, AAP, Mollie Price, CFA, and the Toy Association do not believe the color of water beads should factor into whether water beads are toys. By contrast, Bindi Naik-Mathuria, Christian Beasley, U.S. Public Interest Research Group (PIRG), and That Water Bead Lady contend the color of water beads should be restricted to neutral or clear colors, so they don’t look like candy or other edible items.

Response: This rule does not regulate the color of water beads. Colorful water beads and non-colorful (*i.e.*, clear) water beads both present the same hazard and thus both are within the scope of the rule. While colorful water beads may be more appealing to children, as noted by commenters, non-colorful water beads may be harder to locate if lost or dropped and later found by a young child and ingested. Non-colorful water beads are also just as likely as colorful water beads to pose a hazard. Therefore, both colorful and non-colorful water beads are subject to the rule.

4. Adhesion

Comment: North American Society for Pediatric Gastroenterology, Hepatology and Nutrition (NASPGHAN) states they are not familiar with water bead products sticking together. However, they suggest there is a likelihood that water beads could aggregate with each other or

with other substances and cause an obstruction. The commenter cited a study by Pasma et al.²⁸ that found 12 cases of care escalation reported when multiple water beads were ingested. That Water Bead Lady indicates that in a case in Pakistan, a child died after ingesting water beads, which upon examination, had turned into a mushy, fragmented mass inside the gastrointestinal tract. That Water Bead Lady also provides a case study by Kim et al., 2020,²⁹ which described water beads that became impacted with food in the small bowel. Brad Bergeron, Sarah Desousa, Anonymous, Marianne L'Abbate, Jane Miller, CFA, and American Academy of Pediatric Surgeons (AAPS) assert that water beads can stick together and that multiple medical professionals have shared anecdotal evidence indicating that is the case.

Response: None of the commenters provide convincing evidence that water beads stick together within the human digestive tract. Staff agrees that, as indicated in the study by Pasma et al. and the case from Pakistan, provided by the commenters, that water beads can be found aggregated together with food and other substances in any area of the intestine where an expanded water bead cannot pass naturally, causing an obstruction. However, CPSC is unaware of any incidents of water beads sticking to each other or clumping together to cause an intestinal obstruction.

Based on further CPSC testing, CPSC has found that water beads can clump together when soaked in whole milk or baby formula, depending on the mixture type. Water beads will partially grow by absorbing the water available within the milk or baby formula, leaving a sticky milky substance consisting of the leftover fats and proteins, which cause instances of clumping. However, once the clumps are immersed in water, the water beads will fully expand and separate. Any clumped mass of milk and water beads ingested or that may form in the stomach will separate in the aqueous environment of the small intestine. Therefore, water beads clumping

²⁸ Pasma EA, Khan MA, Kolasinski NT, Reeves PT. Water bead injuries by children presenting to emergency departments 2013-2023: An expanding issue. *J Pediatr Gastroenterol Nutr.* 2024 Sep;79(3):752-757. doi: 10.1002/jpn3.12333. Epub 2024 Jul 24. PMID: 39045753.

²⁹ <https://pubmed.ncbi.nlm.nih.gov/articles/PMC7808832>.

together in milk or baby formula that have been ingested should not present an obstruction hazard due to clumping or sticking together.

Comment: Brianna Zimmerman, AAPS, and AAP note that while it appears that traditional expanding water beads do not have a strong tendency to stick together, there are similar products that are designed to stick together such as Aquabeads. The product Aquabeads “is a bead toy that magically sticks together with water” according to their website.

Response: Aquabeads are not within scope of this rule because they are not a liquid absorbent polymer and do not expand when soaked in liquid, but rather they are composed of a rigid material that allows them to stick together when exposed to water. In fact, they dissolve when soaked in water for several hours. Thus, Aquabeads do not present the expanding material hazard that water beads do.

5. IDI Issues

Comment: The Toy Association asserts the example presented for water bead aspiration incidents does not support the position taken in the NPR. For the IDI 201130CCC3196, the aspiration occurred after the child vomited water beads that were in the stomach. This hazard potential is not specific to water beads, and relates to any object, including food and other matter, since aspiration from vomiting is a known hazard in any situation.

Response: Staff disagrees with the commenter’s assertion that the aspiration incident does not support the position taken in the NPR. In the IDI referenced by the commenter, there is no evidence that supports the assertion that the child aspirated ingested water beads only after vomiting. Instead, according to the IDI, the victim aspirated water beads in addition to ingesting water beads. In any case, vomiting is a common symptom after water bead ingestion and aspiration of water beads into the airways by any means will result in a water bead in a victim’s airway that may continue to expand. This expansion can lead to injury or death.

Comment: The Toy Association asserts that the IDI 180104CBB1236 listed in the NPR as an example for the hazard pattern for choking relates to a nasal obstruction instead of a choking

hazard. Additionally, the commenter asserts that the NPR outlines the hazard associated with large, expanded water beads without addressing whether these water beads would conform to the existing ASTM F963 requirement.

Response: As stated in the preamble of the NPR (89 FR 73031), staff are aware of one choking incident. In that incident, the size of the water bead is not known. However, a 20.0 mm diameter expanded water bead that meets the current ASTM F963 expanding material requirement, which allows for passage through a 20.0 mm diameter gauge, is still large enough to pose a choking hazard. The 5.0 mm gauge size diameter and expansion limits in the rule address a potential choking hazard. IDI 180104CBB1236 does not describe a choking incident, but it was provided as an example to demonstrate how caregivers commonly place water beads in water within reach of children for prolonged periods of time so the water beads can fully expand in advance of a child's playtime. The expanded water beads may then pose a choking hazard because they are accessible to children.

Comment: The Toy Association states IDI 230613CBB1591 presents a circumstance relating to an intestinal obstruction resulting after water beads were released from a ball, like a stress ball received from a party goodie bag, and which was described by CPSC as being expected to be used as a toy. Without information to confirm whether the product was designed, intended, marketed, and sold as a toy, the commenter asserts that it is not reliable to assume that the product was actually a toy.

Response: The commenter suggests that the product involved in IDI 230613CBB1591 may not have been a toy. While the evidence included in the IDI does not provide information to allow definitive identification regarding whether the product is a toy, it does describe the product as a clear ball containing water beads and pink and blue glitter that was provided in a goodie bag from a birthday party, and therefore, likely a toy. Based on the description of the product in the incident, the description indicates that it was likely a toy stress ball containing water beads that released water beads presenting an ingestion and insertion hazards to children. CPSC is aware of

at least six other incidents involving toy squeeze balls releasing water beads. However, if CPSC determines that a product is properly designed, manufactured or marketed for ages 14+ years old, then the product is outside the scope of this rule.

Comment: The Toy Association notes the basis for the proposed maximum water bead size requirement in the NPR is based on IDI 230707CBB1698. Firstly, the commenter notes this incident did not result in an intestinal obstruction; although an enema was prophylactically applied since the child intentionally ingested a large number of water beads, it is not clear whether the enema was required to pass the water beads. Secondly, the commenter states that in the absence of any scientific basis for determination, staff are applying the smallest recorded size of water bead in a set where all water beads, up to 15 mm diameter, passed through the child's intestinal tract without obstruction. Thirdly, the commenter asserts that since the 9.0 mm diameter is based on the smallest water bead in this set, the value observed could have been any value which can and will depend on the variation in the product assessed versus any other set obtained (*i.e.*, the set could have had water beads down to 10 mm or 11 mm diameter).

Response: The incident referred to by the commenter is IDI 230707CBB1698, which describes a 3-year-old female who ingested approximately 1,200 small water beads (approximately 1 tablespoon before expansion). The child successfully passed all the water beads through her digestive system with the aid of a mineral oil enema. The sizes of those specific expanded water beads were not provided in the IDI. However, samples of the same product purchased and collected by CPSC showed full expansion of water beads after being soaked in deionized water, with expansion ranging between 9.32 mm and 15.20 mm in diameter.

To achieve the highest level of safety feasible, the NPR originally proposed requiring the use of a 9.0 mm diameter test gauge based on the size of the smallest water bead that was known to pass through the body without causing an intestinal obstruction. However, based on further information provided by commenters, as explained below in section B, Mechanical Requirements, the final rule uses a 5.0 mm diameter test gauge.

B. Mechanical Requirements

1. Size Requirement for Water Beads Should be Smaller

Comment: That Water Bead Lady asserts that a 9.0 mm diameter size limit for water beads is too large to ensure safety. Due to the swelling properties of water beads, the risk of impingement within the nasal cavity or ear canal will not be mitigated at this size. Reviewing Sterling et al.'s paper, "Destructive Otologic Foreign Body: Dangers of the Expanding Bead,"³⁰ the commenter indicated that the external auditory canal (EAC) of their patient measured only 5.9 mm in diameter. A water bead as small as 4.5 mm diameter could still enter this space and expand. Additionally, CFA provided a study which included data showing the average diameter of a child's airway varies but it is smaller than the airway of an adult.³¹ This study shows the average diameter of the cricoid cartilage of a 0-1 year old is 6 mm, a 1-2 year old is 7.5 mm, a 2-4 year old is 8.0 mm, and a 4-5 year old is 9.0 mm.

AAPS states the 9.0 mm diameter limit is too big to prevent hazards regarding aspiration. Jared Shelton, Petia Paneff, and Elizabeth Berdan suggest that since the rule is based on limited data, the 9.0 mm diameter performance requirement may not be adequate, and further investigation would be beneficial.

Marianne L'Abbate, Brad Bergeron, Sarah Desousa, Anonymous, Connor Mitchell, AAPS, AAP, and Jame Miller contend that even at 9.0 mm diameter, water beads could obstruct the intestines of small children, especially if they have had previous intestinal surgery and have narrow intestines (stricture) or a medical condition that causes thickened intestines.

Christopher Cochran suggests a size limit of 7.0 mm, instead of 9.0 mm diameter, may better protect safety hazards for infants. AAPS and AAP recommend limiting the size to 2.0 mm or 3.0 mm diameter.

³⁰ <https://jamanetwork.com/journals/jamaotolaryngology/fullarticle/2541395>.

³¹ Iowa Head and Neck Protocols "Pediatric Airway - Cross sectional area." <https://medicine.uiowa.edu/iowaprotocols/pediatric-airway-cross-sectional-area#:~:text=The%20average%20diameter%20of%20the,3%20mm%20to%202%20mm>.

Response: That Water Bead Lady provides incident information involving a young girl having a water bead inserted past her EAC, which measured 5.9 mm in diameter. After the water bead expanded to 9.8 mm diameter, profound sensorineural hearing loss was present on audiogram, and labyrinthitis ossificans of the cochlea and semicircular canals were observed on imaging after surgery. CFA provided an additional study from the Iowa Carver College of Medicine regarding pediatric airways that indicated the average diameter of the cricoid cartilage of a 0-1 year old is 6.0 mm.

While the Sterling et al. paper indicates a young girl having an EAC measuring 5.9 mm diameter, the age of the girl is unclear. Additionally, when revising the gauge size diameter, a safety factor should be included as a buffer to account for additional uncertainties. Based on this information, the gauge size diameter in the final rule is being reduced from 9.0 mm to 5.0 mm diameter to account for the possible variation in EAC sizes due to age and to include a safety factor. Therefore, as a result of the smaller final expansion size limit, the 50 percent expansion limit is no longer necessary and is being removed from the final rule, as explained below in section 2, 50 Percent Expansion Limit.

Regarding potential children having narrow intestines and a higher risk of blockage, the revised gauge size of 5.0 mm diameter should account for more narrow intestines.

While other commenters also provide suggestions on what the gauge size should be, such as 7.0 mm, 3.0 mm or 2.0 mm diameter, those commenters do not provide relevant data or information to support using those specific gauge size diameters to revise the limit in the final rule.

2. 50 Percent Expansion Limit

Comment: Erin Brennan, the Toy Association, and Gel Blaster Inc. assert the new performance requirements for these products essentially regulate water beads out of existence. A 50 percent expansion limit corresponds to an absorption rate of about 3x, while sodium polyacrylate, the super absorbent polymer used in hydrogel projectiles, has a minimum

absorption rate of 10x. Thus, they argue that a 50 percent growth limit would essentially be a ban on water beads as toys. The commenters suggest, based on the proposed 50 percent expansion limit, that a water bead with a 1.0 mm diameter that expands to more than 1.5 mm diameter would fail the proposed rule, but doesn't appear to be a hazardous size. Additionally, Alan Kaufman states the independent 50 percent expansion limit proposed by the agency has no valid supporting rationale. Also, he expressed concern CPSC may have inadvertently increased the likelihood of choking and ear and nose insertions and increased the likelihood of these water beads being lost and later ingested.

Response: Based on comments, as described above, the Commission is removing the 50 percent expansion limit from the final rule and reducing the gauge size to 5.0 mm diameter to reduce the severity of injuries resulting from ear and nose insertions. The Commission agrees with the Toy Association's assertion that a 1.0 mm diameter water bead that can expand to 1.5 mm diameter is unlikely to be hazardous but would still fail to comply with the proposed 50 percent expansion limit. Staff concludes reducing the gauge size diameter from 9.0 mm to 5.0 mm in the final rule will improve the safety of water beads and improve medical and health outcomes versus combining the proposed 50 percent expansion limit with a larger size limit of 9.0 mm diameter. Staff notes removing the 50 percent expansion limit means that super absorbent polymers such as sodium polyacrylate could still be used in water bead toys, as long as the other requirements of this rule are met.

Comment: The Toy Association states the NPR has made a preliminary determination that the current 50 percent expansion limit in EN71-1 (European Toy Safety Standard) is inadequate as a stand-alone requirement for expanding water beads, apparently on the basis that a theoretical water bead that expands less than 50 percent would present an obstruction hazard since it could expand from 9.0 mm to 13.5 mm diameter, and then likely cause a gastrointestinal blockage if a child ingested it, while apparently not considering that the same would be true of any other non-expanding material that has a diameter of 13 mm or greater.

Response: Staff consider the current 50 percent expansion limit in EN71-1 to be inadequate as a stand-alone requirement because a dehydrated water bead of 9.0 mm diameter could expand to 13.5 mm diameter and still comply with the 50 percent expansion limit despite potentially causing an intestinal blockage.

The commenter suggests that non-expanding material with a diameter of 13.0 mm could cause an intestinal blockage. As stated in the preamble of the NPR (89 FR 73028), objects of this size, such as marbles, do not grow after being swallowed. Unlike water beads, marbles and other smooth, solid objects can frequently be located and identified by x-ray due to their density. Once located, marbles can be removed endoscopically if detected early enough, especially if they appear to be too large to pass through the stomach or the remainder of the digestive tract. By contrast, water beads can remain small within the stomach and proximal small intestine, eventually growing larger as they move into the distal small intestine and causing a small bowel obstruction that frequently requires surgery to resolve.

3. Consequence of Reducing Allowable Expanded Size for Water Beads

Comment: Patricia Rowell and Craig Farrow contend that downsizing the size of water beads only makes them more dangerous to children and thus easier to choke on.

Response: The commenters do not provide evidence to support their claim that reducing the expansion size of water beads makes them more dangerous and easier to choke on. However, the physical characteristics of objects that pose a choking hazard include large size, round shape, and smooth texture. For example, an expanded water bead with a diameter of 5.0 mm or less is less likely to present a choking risk to children than a bead with a larger diameter, solely due to the smaller diameter of the water bead.

Comment: Jake Peterson states that reducing the allowable expansion size creates a situation where the lack of enlargement might prevent any detection. So, if a child were to place a water bead in their ear/nose, and it does not enlarge, then it is possible for the water bead to go fully undetected for a long time. The commenter asks: how long could a water bead stay in an

ear canal or nasal cavity without enlarging; if the water bead never enlarges, how long would it stay there before other symptoms develop; and are those symptoms potentially worse than if the water bead did enlarge and was detected relatively quicker.

Response: If a water bead doesn't expand after being inserted into the ear or nose, it could stay undetected for an undetermined amount of time (hours, days, weeks, months). However, if a water bead does not expand within the ear or nose, the physical injuries or health outcomes from an unexpanded water bead would be more like the injuries and health outcomes from insertion of a standard bean, or round toy part, or other bead-like object that a child might insert into their ear or nose. No expansion, or limited expansion, reduces the injury to the ear or nose that CPSC has seen from water beads in incident data where the expanded water bead leads to a more severe injury due to the expansion damaging the tissues of the nose and ears. Larger expanded beads lead to increased nasal and ear injury.

4. Size Requirement for Water Beads Should be Larger

Comment: The Toy Association asserts the NPR misrepresents the basis for the ASTM proposed 12.0 mm diameter gauge by stating the 12.0 mm proposed diameter was based on consideration of one incident. They note that this value is 1.0 mm smaller than the smallest confirmed size (13.0 mm diameter) of a water bead that resulted in an intestinal obstruction based on the incident data provided by CPSC. The basis for the proposed size was also extensively discussed in the ASTM F963 water bead work group meetings. Gel Blaster Inc. and SplatRball support the ASTM F963 water bead work group's proposal of a 12.0 mm diameter restriction for water beads. They support CPSC postponing the development of this final rule to allow the ASTM group to continue refining revisions that can enhance water bead safety.

Response: Regarding the ASTM proposed 12.0 mm diameter threshold, as stated in the preamble of the NPR (89 FR 73038), staff are aware of an incident in which a 13.0 mm diameter expanded water bead caused an intestinal obstruction in a 13-month-old female. However, this incident only confirms that a 13.0 mm diameter water bead can cause an intestinal obstruction.

This incident did not involve slightly smaller water beads, so it does not demonstrate that a slightly smaller water bead, such as 12.0 mm diameter, could safely pass through the intestinal tract of the 13-month-old female. Additionally, neither the incident information nor ASTM's proposed 12.0 mm diameter threshold account for children younger than 13-months-old, who may have smaller intestines than older children.

Instead, the NPR cited IDI 230707CBB1698 to establish an appropriate size to mitigate the hazards associated with water beads. This incident describes a 3-year-old female who successfully passed approximately 1,200 water beads. After purchasing and testing a sample of these water beads, CPSC noted the expanded size ranged from 9.32 mm and 15.20 mm diameter. Therefore, to ensure the highest level of safety feasible, the proposed rule limited the gauge size diameter to 9.0 mm, which was based on the size of the smallest water bead that was known to pass without causing an intestinal obstruction. However, as discussed above, based on the response to comments, the gauge size diameter has been reduced from 9.0 mm to 5.0 mm in the final rule.

Gel Blaster Inc. and SplatRball also request that CPSC postpone the development of this final rule to allow the ASTM group to continue refining revisions that can enhance water bead safety. However, to date, no voluntary standard has been published by ASTM that addresses the hazards presented by water bead toys. Therefore, the Commission is issuing this final rule to address the hazards presented by water bead toys.

5. Further Research Needed on Size Requirement

Comment: Kirksey Croft notes it is crucial to recognize that the 9.0 mm gauge diameter differs significantly from established diameters for testing choking hazards in other children's products. For example, the ASTM F963 Toy Safety Standard uses a small parts cylinder with a 31.7 mm diameter opening. Internationally, the European Toy Safety Standard EN 71-1 covers expanding materials like water beads and specifies a testing diameter of 31.7 mm. Even the current standard for expanding materials such as water beads, section 4.40 *Expanding Materials*

of ASTM F963-23, prescribes a larger 20.0 mm diameter gauge with applied force, which is already significantly smaller than the referenced 31.7 mm diameter.

Response: The commenter correctly cites the ASTM F963 Toy Safety Standard, which uses a small parts cylinder with a 31.7 mm diameter opening. However, this small parts cylinder is used as a gauge to simulate the throat size of a child under 3-years-old and determine what objects or pieces they can potentially choke on. Whereas the 9.0 mm gauge diameter, proposed in the NPR, is based on incident data showing gastrointestinal blockages caused by water bead toys.

The commenter correctly cites the European Toy Safety Standard EN 71-1 as regulating expanding materials such as water beads, but incorrectly claims the standard specifies a testing diameter of 31.7 mm. Instead, EN 71-1 specifies that expanding materials, such as water beads, that when dehydrated fit in the small part cylinder, shall not expand more than 50 percent of its original size, in any dimension.

The commenter also points out “even the current standard for expanding materials such as water beads, section 4.40 *Expanding Materials* of ASTM F963-23, prescribes a larger 20.0 mm diameter gauge with applied force, which is already significantly smaller than the referenced 31.7 mm diameter.” However, this 20.0 mm diameter gauge was developed based on the size of the pyloric sphincter, which leads from the stomach to the small intestine, within the gastrointestinal tract of an 18-month-old child. At the time the expanding materials requirement was created, the pyloric sphincter was thought by the drafters to be the most likely site where gastrointestinal blockages would occur. However, as explained in the preamble of the NPR (89 FR 73034), incident data show water beads successfully passing through the pyloric sphincter before expanding and creating blockages at the ileocecal valve, which leads from the small intestine to the large intestine. Therefore, the 9.0 mm diameter gauge proposed in the NPR was justified based on this incident data, to prevent blockages at the ileocecal valve, which is a more

appropriate anatomical structure on which to base the diameter of the test gauge than the pyloric sphincter.

Lastly, as explained above, additional incident information and studies from commenters have convinced CPSC to modify the gauge size diameter from 9.0 mm to 5.0 mm for the final rule.

6. Mechanical Test Should Mirror Intestines

Comment: Brianna Zimmerman is doubtful that only exposing water beads to gravitational force during the gauge test is replicative of the forces of a child's digestive tract. Typical esophageal peristalsis pressure is variable and dependent on multiple factors. To truly be representative of an ingestion scenario, the gauge test should account for the wide range of pressures that water beads will experience in the gastrointestinal tract.

Response: Although placing the expanded water bead in a gauge and only relying upon the force of gravity to verify if the water bead passes through is not representative of what happens to water beads within the digestive tract, it is the most stringent test and therefore achieves the highest level of safety feasible. Applying other forces to the water bead as described in the comment could assist a water bead in passing through the gauge or by breaking the bead into smaller fragments that pass through the gauge, and if such forces were included in the test, it would not achieve the highest level of safety feasible.

Comment: Savannah Mesel notes the proposed gauge test for water beads to be expanded in deionized water prior to the water beads being tested, but the commenter contends deionized water is vastly different from the harsh environment of the stomach and intestines. Additionally, Brianna Zimmerman states that distilled water is used for testing, which is vastly different from the harsh environment of the stomach and intestines.

Response: Deionized water is being used for the gauge test to be consistent with the test methods specified in section 4.40 *Expanding Materials* of ASTM F963-23. As noted in the preamble of the NPR (89 FR 73037), the largest expansion occurs in deionized water. Distilled

water is not used in testing. Additionally, the stomach is a more acidic environment, in which water beads will not expand to their full potential. In contrast, the small intestine is a more neutral environment (similar to water) in which water beads will expand to their full potential. Water beads spend more time in the small intestine than in the stomach, and so grow in a more neutral environment, compared to the stomach.

7. Caliper Measurements

Comment: Brianna Zimmerman asserts the proposed rule does not state with specificity how the standardized caliper measurements are to be taken to determine the size increase between the dehydrated and hydrated form. The commenter asserts that instructions in the proposed rule are not sufficiently specific to ensure all operators are measuring water beads using the same method.

Response: The issue raised by the commenter concerning caliper measurements in the proposed rule is now moot because of the removal of the 50 percent expansion limit from the final rule and the test method will no longer include a step requiring the use of calipers to measure and calculate expansion amount. Instead, the expanded water bead will be tested using the 5.0 mm diameter gauge after full expansion has been achieved.

8. Accessibility Test Questions

Comment: Intertek Shenzhen asks what the rule means by “water beads removed from a toy.” Does it mean to apply the 16 CFR 1500.50-53 use and abuse tests of toys which tests for accessibility.

Response: Use and abuse testing under 16 CFR 1500.50-53, which is used to determine accessibility, is also required by ASTM F963-23, and includes various impact, tension and torque tests to determine accessibility of toy components. However, this use and abuse testing does not apply to this rule. This rule applies to all water bead toys and other toys that contain water beads, regardless of accessibility of the water beads. The rule is more stringent than mandating use and abuse testing for accessibility because the rule requires any water beads

contained within a toy to be removed from the toy to test and measure expansion per the requirements in the rule.

Comment: The Toy Association asserts the NPR would require that all water beads, even those contained within a toy, to meet the performance requirements, but existing CPSC standards for products that pose similar hazards rely on ensuring inaccessibility as a primary safeguard. The commenter asserts that CPSC has not provided any reason why maintaining inaccessibility cannot be an effective requirement here. Similar to water beads, high-powered magnets and button cell batteries pose specific hazards if ingested. In both of those cases, if they are contained within a toy, standards apply to test for accessibility. The NPR contends that water beads contained within toys may become accessible by a child biting into the product and liberating the water beads. The commenter states that there is no explanation as to why this risk is any different from that posed by a high-powered magnet or a button cell battery.

Response: The commenter suggests that there should be an accessibility test performed before subjecting water beads contained within a toy to the proposed requirements. However, CPSC is aware of multiple incident reports stating that toy squeeze and stress balls have had their internal water beads pop out over time and other incident reports of children biting into the toy ball and ingesting water beads. These incidents could potentially be addressed through test procedures to represent long-term cyclic squeezing and tests to represent biting of these toy squeeze and stress balls. However, ASTM F963-23 currently has only impact, tension and torque test procedures for toys to determine accessibility, but it does not currently have test procedures to adequately address the long-term cyclic squeezing and occasional biting of toy squeeze and stress balls. Rather than creating additional use and abuse testing requirements, the rule applies a uniform test for water beads that ensures that water beads in a toy are not hazardous. Therefore, the rule requires that water beads contained within a toy, such as a squeeze or stress ball, be subject to the rule to achieve the highest level of safety feasible.

C. Acrylamide Requirements

1. Acrylamide Limit Should be Higher or Removed

Comment: Alan Kaufman and the Toy Association assert that CPSC has mistakenly adopted the Agency for Toxic Substances and Disease Registry's (ATSDR) acute-duration exposure limit of 0.01 mg/kg-day, which calculates to 65 µg based on the body weight of a small 6-to 8-month-old female. Alan Kaufman and the Toy Association state there are numerous issues with the ATSDR exposure limit, as noted below:

1. The commenters both state that it appears that ATSDR relied almost entirely on data from one study to derive the minimal risk level (MRL), Sublet, et al. (1989). These data were derived from feeding male rats acrylamide in distilled water for five days at varying doses in two separate experimental runs. These males were then allowed to mate with untreated females, which were sacrificed at 15 days post-mating and the fetuses examined for developmental and implantation anomalies, a toxic endpoint that has limited applicability to children. These raw data were fed into a Physiologically Based Pharmacokinetic (PBPK) model developed by Sweeney, et al. (2010) to estimate blood levels. This derivation utilized uncertainty factors of three for extrapolation from animals to humans with dosimetric adjustment and 10 for human variability, which collectively have the effect of arbitrarily reducing the MRL by a factor of 30.
2. The commenters both state CPSC is mistakenly using ATSDR's derived acute-duration exposure limit of 0.01 mg/kg-day; ATSDR defines acute-duration oral exposure as daily or continuous dosing for up to 14 days. However, several studies have dosed humans at up to 3 mg/kg as a single oral dose with no ill effects. The commenters state that one single oral exposure is what needs to be addressed for risk of ingestion by a child. A level approximating 3 mg/day, or more, is a more appropriate limit (reference: Fennell and Friedman, 2005).

3. The commenters both state that ATSDR's exposure limit is based on rodent studies, and that acrylamide metabolism differs significantly between rodents and humans. Rodents metabolize acrylamide largely via the CYP 2E1 oxidation pathway to glycidamide, and humans metabolize acrylamide via conjugation with glutathione to a much greater extent.
4. The commenters both explain that acrylamide is also known to occur in many foods at levels that can create higher exposures than the proposed acrylamide limit in water beads. Both commenters provided several examples of acrylamide in food, with potato chips having up to 8440 ppb acrylamide per U.S. FDA or up to 9670 ppm per ATSDR. Alan Kaufman also noted that vegetarians and vegans have much higher blood levels of metabolites due to their plant-based diets.
5. In addition, both commenters assert that there is evidence that a significant amount of acrylamide is produced by the body itself. The German Federal Institute for Risk Assessment (BfR) has studied this issue and found that up to 48 percent (blood) and 25 percent (urine) of C13-labeled acrylamide metabolites are generated by the body itself (reference: Monien, et al., 2024).

The commenters contend that the above points indicate that CPSC's proposed acrylamide limit is several orders of magnitude too low. The commenters also assert it is clear that ingestion and endogenous production of significant amounts acrylamide is a daily event for most humans, and the human body has evolved mechanisms to rapidly metabolize and excrete acrylamide without apparent adverse health effects.

Response: The responses below are presented in the same order as the issues raised in the comment above.

1. The commenters' description of the derivation of the ATSDR acute exposure MRL of acrylamide appears to be accurate. Their concern about the reproductive toxicity endpoint not being relevant to children is noted. However, the "no observed adverse effect level" (NOAEL)

in the Sublet et al. (1989) study was 5 mg/kg-day. Other acute or short-term studies described in the ATSDR Toxicological Profile of Acrylamide included Burek et al. (1980) and Tyl et al. (2000b), and both of these studies reported dose-dependent health effects in acrylamide-treated animals as low as the 15 to 20 mg/kg-day range with NOAELs of 5 mg/kg-day, the same as NOAEL in the Sublet study. The Burek et al. (1980) study reported behavioral and histological signs of neurotoxicity in dose groups above 5 mg/kg-day. The Tyl et al. (2002b) study reported reduced body weight in animals given 15 mg/kg/day acrylamide for 5 consecutive days, which could be related to neurological effects. Staff notes that these studies with neurological effects have the same NOAEL value as the critical Sublet et al. (1989) study. ATSDR applied PBPK and benchmark dose modeling to data from the Sublet et al. (1989) study to derive the acute-duration oral exposure MRL, using more advance techniques than a traditional point of departure and uncertainty factors approach. Staff do not currently have the resources to perform PBPK modeling, and the Burek et al. (1980) and Tyl et al. (2000b) study reports did not provide enough quantitative data for staff to apply benchmark dose methods. Therefore, applying a traditional approach, staff derived an acute oral acceptable daily intake (ADI) for acrylamide by using the 5 mg/kg-day NOAEL from Burek et al. (1980) and Tyl et al. (2000b) and an uncertainty factor of 10x for interspecies variability and 10x for within species variability. The resulting acute oral ADI is 0.050 mg/kg-day or 50 µg/kg-day. This value is five times the MRL used in the originally proposed acrylamide extraction limit, which was 0.01 mg/kg-day. Adjusting for the chosen body weight of 6.5 kg, the revised acrylamide extraction limit for the final rule is 325 µg (50 µg/kg-day x 6.5 kg = 325 µg/day). Staff understand the commenters' concerns that reproductive toxicity as the critical effect in the Sublet et al. (1989) study may be of limited relevance to young children ingesting water beads. The acrylamide limit for the final rule is based on neurotoxicity endpoints for which relevance to children is more apparent.

2. While the commenters suggest that there are several human studies of acute high-dose exposure to acrylamide, they only cited one study. The Fennell and Friedman (2005) paper cited

was a toxicokinetics study conducted in adult male subjects and did not measure the sensitive health effects that could affect children. Although it is CPSC's policy to favor quality human data over animal studies in evaluating dose-response and risk, the available human data for acute acrylamide exposure does not address the exposure and hazard scenario for acrylamide in water beads.

3. The commenters are correct that there are differences in the dominant pathways by which humans and rats metabolize acrylamide. The CYP2E1 pathway converts acrylamide into the active metabolite glycidamide, which is the active component in many of the toxic effects of acrylamide. The enzyme glutathione S-transferase (GST) conjugates acrylamide to detoxify and promote urinary excretion. Rats and humans have both pathways, and GST is the primary pathway in adult humans. However, young children have lower GST activity than adults, and staff do not have enough data to compare the relative GST and CYP2E1 activity levels between toddler-age human children versus adult rats. ATSDR stated, "It is not known whether children are more susceptible than adults to the effects of acrylamide." Given the uncertainty in the limited available data, staff errs on the side of caution and consider the rat studies appropriate for assessing the risk of acute acrylamide exposure to children.

4. Staff are aware of food as a chronic exposure source for acrylamide. CPSC's objective in the rule is to limit the additional acute exposure to acrylamide (above baseline daily exposures from other sources) to children who ingest water beads. The animals used in the toxicity studies were likely exposed to dietary acrylamide in their commercially produced rodent feed, which is typically made of grains that are dehydrated by exposure to heat (conditions that produce acrylamide). Because of this, the animal study already accounts for dietary acrylamide exposure, although staff concedes that the amount of daily dietary acrylamide exposure may be variable in both humans and lab animals. Staff have taken note of Alan Kaufman's statement about plant-based diets leading to greater acrylamide exposure than mixed (omnivorous) diets in

one study, but this information of different diet types is not relevant to setting the limit for acrylamide in water beads for this rule.

5. After staff's review of recent literature on endogenous acrylamide (e.g., Goempel, et al., 2017), including the Monien et al. (2024) and BfR (2024) reports cited by the commenter, it appears that the endogenous production of acrylamide metabolites is a proposed hypothesis with no known or confirmed biochemical process or pathway. The Monien et al. (2024) and BfR (2024) reports described potential confounding exogenous sources of acrylamide in the "raw food" subject meant to represent an acrylamide-free diet. Monien et al. (2024) reported that the estimated amounts of endogenously produced acrylamide corresponded to dietary acrylamide doses of 0.2 to 0.4 $\mu\text{g}/\text{kg}\text{-day}$, which is less than 1 percent of the 50 $\mu\text{g}/\text{kg}\text{-day}$ acute oral ADI used to derive the acrylamide limit in the final rule.

Comment: The Toy Association contends that the NPR is misleading in stating that "ASTM F963 does not specifically mandate testing for hazardous chemicals," and then stating an acrylamide testing mandate is required. While the Federal Hazardous Substances Act (FHSA) does not mandate acrylamide testing specifically, FHSA does mandate that materials must comply with the requirements of FHSA, as is required in section 4.3.1 *Hazardous Substances* of ASTM F963-23. As such, the commenter asserts that the statement that an acrylamide test mandate is missing is not a basis for arguing a need for the proposed acrylamide test.

Response: As noted in the preamble of the NPR (89 FR 73034), under section 4.3 of ASTM F963-23, there is a general FHSA toxicity and hazardous substances compliance requirement for all toys. However, specific levels of compliance are not identified in section 4.3. Also, as noted in the preamble of the NPR (89 FR 73034), ASTM F963-23 does not have any test methods or limits for acrylamide monomer in water beads. Therefore, the current ASTM standard is inadequate to provide the highest level of safety feasible to ensure that the chemicals in water beads are non-toxic. While CPSC does not have incident data reflecting acute acrylamide poisoning from water beads, the presence of acrylamide in several water bead

products that CPSC tested demonstrates a potential chemical hazard. For example, in March 2024 CPSC announced unilateral warnings^{32,33} for two water bead toy products that contained levels of acrylamide in violation of the FHSA. If those water beads were ingested, it does pose a risk of acute toxicity to children from acrylamide exposure.

Comment: The Toy Association and China World Trade Organization (WTO) / Technical Barriers to Trade (TBT) National Notification & Enquiry Center notes that the only water beads that were deemed as having dangerous levels of acrylamide by CPSC are those sizes that would not comply with the proposed rule's size limits. This is the case using either the 9.0 mm diameter limit proposed in the NPR or the 12.0 mm diameter limit proposed in the ballot by the ASTM F963 water beads working group. The commenters state that these large water beads, having high levels of acrylamide, would be removed from consideration because they would not meet either of the proposed size requirements. Therefore, they assert that the test data does not support the assertion that an acrylamide test for all water beads is necessary.

Response: CPSC is not aware of any data that supports the commenters assertion that all water beads in compliance with the size requirement would also necessarily comply with the acrylamide limit, making the acrylamide test unnecessary. While CPSC found hazardous levels of acrylamide in two water bead toy products that would not meet the proposed size limits, there is no evidence to suggest that smaller water beads could not possess toxic levels of acrylamide. Therefore, because CPSC is aware of hazardous levels of acrylamide in water bead toys, the acrylamide requirement in the rule is necessary to address the hazard and achieve the highest level of safety feasible.

2. Acrylamide Limit Should be Lower

³² <https://www.cpsc.gov/Newsroom/News-Releases/2024/CPSC-Warns-Consumers-to-Immediately-Stop-Using-Jangostor-Water-Beads-Due-to-Chemical-Toxicity-Hazard-Violation-of-Federal-Ban-of-Hazardous-Substances-Sold-on-Amazon-com>.

³³ <https://www.cpsc.gov/Newsroom/News-Releases/2024/CPSC-Warns-Consumers-to-Immediately-Stop-Using-Tuladuo-Water-Bead-Sets-Due-to-Chemical-Toxicity-Hazard-Violation-of-Federal-Ban-of-Hazardous-Substances-Sold-on-Amazon-com>.

Comment: That Water Bead Lady, Petia Paneff, Sara Desousa, and Jane Miller state the minimal risk level (MRL), cited in the rule for the acrylamide limit, is based on fertility testing conducted on male Long Evans hooded rats in a 1989 study. The commenters note, use of that study is highly questionable when applied to the exposure levels expected in infants and toddlers. Additionally, CFA notes that the ATSDR describes in its toxicological profile of acrylamide: “children are not small adults. They differ from adults in their exposures and may differ in their susceptibility to hazardous chemicals.” The commenters recommend that CPSC consider adopting the more stringent intermediate/chronic oral MRL of 0.001 mg/kg-day instead of the acute oral MRL of 0.01 mg/kg-day. The commenters assert that the intermediate/chronic exposure model will better account for the fact that many cases of consumption of water beads remain unnoticed and may continue beyond acute exposure.

Response: As noted in the preamble of the NPR (89 FR 73038), “children’s possible exposure to acrylamide after ingesting water beads would likely be a single, infrequent event (possibly including multiple water beads in a single event). Therefore, the appropriate exposure scenario would be acute rather than intermediate/chronic.” Additionally, the original proposed acrylamide limit of 65 µg was based on an acute-duration MRL of 0.01 mg/kg-day. However, due to information provided by other commenters and as explained above, the updated acrylamide limit in the final rule is set at 325 µg which is based on an acute oral acceptable daily intake (ADI) of 0.05 mg/kg-day.

3. Justification for Acrylamide Requirements

Comment: The Toy Association notes superabsorbent polymers are usually made of either polyacrylate, polyacrylamide, or a combination of the two. The Toy Association states that there is no mention in the NPR that unreacted monomers present a small percentage of the resulting polymer, which is bound within the polymer matrix. Furthermore, they state that while polyacrylate is a common material for water beads, its polymerization process does not utilize acrylamide monomer. The Toy Association asserts that a significant proportion of water beads

either do not have acrylamide monomer present as a contaminant at all, or have it present in very low amounts. Gel Blaster Inc. also asserts that acrylamide, if present at all, would be present well below the proposed acrylamide limit.

Response: CPSC recognizes that not all water bead products are manufactured using acrylamide. However, CPSC has found extractable acrylamide at hazardous levels in two water bead samples, necessitating acrylamide testing for all water bead products, regardless of manufacturing, in order to ensure product compliance with the guidelines described in this final rule. Any water bead toys that do not contain acrylamide or that contain extractable acrylamide less than 325 µg per one large water bead or per 100 small water beads, meet the acrylamide limit requirement in the rule.

Comment: China WTO/TBT National Notification & Enquiry Center notes that separating water beads into small and large sizes and testing 100 small water beads or one large water bead, and the general test method, are different than the European Toy Safety Standard EN 71-9. The commenter states, the U.S. is required, by the principle of transparency, to provide scientific evidence of the sampling method and experimental approach.

Response: The NPR was transparent and provided incident information and support for the separation of small and large water beads in the test method. As noted in the preamble of the NPR (89 FR 73038), the quantities of small and large water bead toys assumed to be ingested are based on water bead toy ingestion incidents and published case reports. Incident data indicate that children tend to ingest only one or two large water beads, while there is evidence of children ingesting hundreds of small water beads.³⁴

Regarding the 4.0 mm dimension cut-off between “small” and “large” water beads, CPSC found that water beads tested by staff, and water beads noted in incident data, tend to fall into two size ranges: either from 1.5 mm to 3.0 mm diameter, or from 5.0 mm to 8.0 mm diameter.

³⁴ Jackson J, Randell KA, Knapp JF. Two-Year-Old With Water Bead Ingestion. *Pediatr Emerg Care*. 2015 Aug;31(8):605-7. doi: 10.1097/PEC.0000000000000520. PMID: 26241717.

This was the basis for staff defining any water bead less than 4 mm in all dimensions as a “small water bead” and any water bead having any dimension of 4 mm or greater as a “large water bead.” Therefore, the test method covers testing for both scenarios.

Finally, the acrylamide limits from the European Toy Safety Standard EN 71-9 were developed to address acrylamide exposure following long-term licking, sucking, and chewing of toys that are intended to be mouthed for a significant amount of time. In contrast, water bead toys have not been found to be mouthed, sucked, or chewed for long periods of time, and are also not intended to be. Therefore, the rule does not adopt the acrylamide testing procedures and limits of EN 71-9.

Comment: Emily Threatt contends that due to the high number of ingestion incidents and the hazards of long-term acrylamide exposure, the more stringent standard for acrylamide requirements of the European Toy Safety Standard EN 71-9 should be adopted. The NPR states that EN 71-9 is not appropriate because it was designed to address acrylamide exposure following the long-term licking, sucking, and chewing of toys intended to be mouthed. The NPR also states water beads are not likely to be mouthed for a significant amount of time. The commenter states, although water beads are not intended to be mouthed, they are mouthed, and the water bead regulation should reflect this reality.

Response: As stated in the preamble of the NPR (89 FR 73033), the European Toy Safety Standard EN 71-9 acrylamide concentration limit has been calculated based on long-term licking, sucking, and chewing of toys that are intended or likely to be mouthed for a significant amount of time. Examples of such products that are mouthed for a significant amount of time are teething rings, rattles, and other hand-held soft plastic toys for young children. In contrast, water bead toys are not intended to be mouthed, nor are they likely to be mouthed for a significant amount of time. According to incident information, water beads are typically ingested relatively quickly and are not mouthed for a significant amount of time; thus, EN 71-9 is not appropriate to use for the acrylamide requirements in the rule.

4. Acrylamide Test Recommendations and Questions

Comment: The Toy Association contends that it is highly unlikely for younger children, such as 6-8 months of age, which was used to estimate the body weight and determine the acrylamide limit, to be physically or developmentally able to obtain 100 small water beads in one instance. The Toy Association states that the 100 small water bead value relates to older children. The Toy Association asserts that it is not appropriate to use a chosen test value of 100 small water beads while also using the selected body weight.

Response: The Commission agrees that children 6-to 8-months of age are less likely than older children to obtain and consume 100 small water beads in a single incident. However, the number of 100 small water beads used in the rule is within the range of documented ingestion incidents, and because of the extremely small size of some dehydrated water bead toys, it is foreseeable that some children in the 6-to 8-month age range who have repeated access to small water beads could consume this many over multiple exposures during the course of a day. Additionally, this value includes a safety factor as a buffer to account for additional uncertainties. Therefore, the number of 100 small water beads used in the test method for small water beads is a more stringent standard for the testing quantity that would further reduce the risk of injury from acute acrylamide exposure in water bead toys to achieve the highest level of safety feasible for water bead toys.

Comment: Max Williams asserts that the test procedure for acrylamide testing proposed in the NPR, which involves a pH neutral solution, does not account for the variations in pH levels that might be present in the stomach or the small intestine.

Response: Although the test method in the rule does not account for pH variation, data gathered by CPSC supports the use of a simplified extraction solution with one pH level as opposed to a testing protocol involving solutions with different pH levels. CPSC previously performed testing designed to simulate water beads traveling through the human digestive tract. Water beads were extracted in a pH-neutral solution to mimic the pH of saliva, followed by a

0.07 N hydrochloric acid solution to mimic the pH of stomach acid, and finally followed by a slightly basic solution to mimic the pH of small intestinal fluid. During this testing, it was noted that of the total amount of acrylamide that was extracted, most leached within the first 24 hours of testing. For simplicity, CPSC tested a 24-hour extraction of water beads in deionized water and observed acrylamide extraction on the same order of magnitude as the multi-day extractions performed across various pH levels. Based on this testing, staff determined that a 24-hour extraction in deionized water is sufficient to estimate acrylamide exposure.

Comment: Petia Paneff and Austin Woods assert a 0.1 mm difference in the diameter of a water bead is unlikely to have any meaningful impact on the potential consumption of the number of water beads. They argue that a child would be just as likely to ingest a handful of 4.0 mm diameter water beads as they would 3.9 mm diameter water beads, potentially resulting in a significant increase in acrylamide exposure. Austin Woods suggests creating additional size designations with different numbers of water beads tested in each designation, while Petia Paneff recommends that acrylamide content in water beads should be evaluated based on the dehydrated weight of the beads.

Response: The commenters are correct that a 0.1 mm difference in the diameter of a water bead is unlikely to have any meaningful impact on the potential consumption of the number of water beads and are calling into question the reasoning of the 4.0 mm diameter size cutoff between testing one large water bead (4.0 mm diameter or greater) and 100 small water beads (less than 4.0 mm diameter). Based on the products tested by CPSC, staff observed that size differences between “small” and “large” water beads of water bead toys currently on the market were distinct enough that the size categorization could be rationally made. All small water beads tested measured, at or below, 3.0 mm diameter (prior to hydration), while all large water beads tested measured well over 4.0 mm in diameter (prior to hydration). The cutoff size of 4.0 mm diameter was chosen because all small water beads were well below this size, while all large water beads were well above it. Practically speaking, it is very unlikely there will be

many 3.9 mm diameter water beads, which are on the edge of 4.0 mm diameter small vs large water bead threshold, because virtually all of the water beads are significantly over or under the 4.0 mm. The decision to test a certain number of water beads was based on incident data, which found that children would typically only swallow one or two large water beads, while small water beads could be ingested in much larger numbers. Regarding the suggestion to test water beads based on dehydrated weight, determining the amount of water beads that a child can grasp is more appropriately based on volume and not dehydrated weight because the smaller water beads have a very low mass, and weight is not a limiting factor on the number of water beads that can be grasped by a child. Basing the extraction parameters on incident data allowed staff to better model and determine the possible acrylamide hazard presented by a product.

Additionally, because not all water beads are spherical when dehydrated and can be different shapes such as cubes and stars, as explained in section VI.C of this preamble, section 1250.4(c).2 of the final rule has been revised to define a small water bead as a water bead being “less than 4 mm in all dimensions prior to hydration” and define a large water bead as a water bead being “greater than or equal to 4 mm in any dimension prior to hydration.”

Comment: That Water Bead Lady and CFA state CPSC should investigate whether water beads break apart within the digestive tract releasing additional acrylamide. Max Williams and AAP also suggest investigating how much acrylamide is released when water beads are chewed and break apart before ingestion.

Response: CPSC has investigated whether water beads break apart within the digestive tract. According to incident data reviewed by staff, and as discussed in the preamble of the NPR (89 FR 73033), ingested water beads do not break apart in the stomach or small intestine but instead remain whole when successfully passing through the digestive tract or when creating a blockage. CPSC has not found evidence of children chewing water beads before or after expansion.

Comment: That Water Bead Lady states CPSC should investigate the effects of acrylamide on the enteric nervous system, mucosa, gut flora, bacteria, and gastrointestinal tissue under simulated conditions of both non-obstruction and obstruction.

Response: The acrylamide limit requirement in the rule is intended to limit the amount of acrylamide intake due to acute acrylamide exposure when water bead toys are ingested. By preventing this exposure in the first instance, it is unnecessary to further research the effects of acrylamide on the enteric nervous system, mucosa, gut flora, bacteria, and gastrointestinal tissue. The Commission considers the acrylamide limit requirement in this rule adequate to address the hazards associated with acute exposure from acrylamide in water bead toys without a need for the type of study suggested by the commenter, which could take years to complete while injuries and death continue to occur.

Comment: SGS seeks clarification on the following language in the NPR: “Following the extraction period, determine the volume of remaining water for each trial, then analyze the water to determine the mass of acrylamide present using an instrument that is able to quantitate acrylamide at levels equal to or less than the proposed limit.” The commenter asks if the volume of remaining water means “the volume of water remaining after the water beads absorb water” or if it means “the water volume added to the dehydrated water beads before the water extraction.” The commenter also asks if the volume of remaining water is used as the final volume in the calculation of acrylamide content, or if the volume of water added to the dehydrated water beads, before the water extraction, is used as the final volume in the calculation.

Response: The “volume of remaining water” refers to the volume of water that remains in the container after the water beads have absorbed water during the 24-hour extraction period. It does not refer to the volume of water initially added to the dehydrated water beads. The “volume of remaining water” is used in the final calculation. It is measured and then multiplied by the measured acrylamide concentration, given by the analytical instrument used to measure

acrylamide concentration, to determine the mass of acrylamide extracted. The volume of water originally added to the dehydrated water beads is not used in the calculation of extracted acrylamide.

Comment: SGS inquires if CPSC has official guidelines on how to completely separate water beads after absorbing water from the remaining water.

Response: While there are no official guidelines regarding the separation of the water beads from the remaining water following the extraction, any means may be used so long as the full volume of remaining water can be separated and measured, and so long as the method used for separation would not add or remove acrylamide from the water to be analyzed. Care should be taken to avoid any losses of the remaining water during separation, as an accurate volume measurement is crucial for calculating an accurate mass of extracted acrylamide.

Comment: SGS asks a question regarding the following language in the NPR: “Because water beads absorb different volumes of water depending on their size, conduct additional tests before performing final acrylamide extractions, to determine what volume of water best allows for full water bead growth without unnecessarily diluting the concentration of extracted acrylamide.” The commenter asks if CPSC has any official guidelines on how to determine the volume as the water volume may affect the result of the acrylamide extraction.

Response: Due to large variations in water bead type, size, and growth potential, CPSC does not have official guidelines on the volume of water to use for extractions, as there is no volume of water that will be appropriate for all water bead toys. Staff recommend first performing a test trial for each type of water bead from each product to determine an appropriate volume of water to use for those water bead extractions. However, these test trials would not be used for the analysis of acrylamide but rather are used to determine the appropriate volume of water that will allow for full growth of the water beads while ensuring that they remain fully submerged in water during the entire 24-hour extraction period. Care should be taken to choose an appropriate volume when using this approach while also minimizing unnecessary dilution of

any acrylamide that may be extracted. Test trials should be conducted under the same extraction conditions required in the rule (water bath at 37 °C, 30 revolutions per minute, 24 hours) which are unchanged from the NPR.

D. Marking, Labeling, and Instructional Literature Requirements

1. Warning Content: Hazard and Consequences

a. Clarifications about water bead growth

Comment: Ayden White, Christian Beasley, Mollie Price, Albert Tacornal, Austin Watson, Zach Gilbert, AAP, and U.S. PIRG suggest revisions to the warning to clarify or add details about the growth of water beads. Ayden White, Mollie Price, Albert Tacornal, Zach Gilbert, AAP, and U.S. PIRG suggest that the warning state more explicitly that water beads can expand over time or can grow after ingestion. Some commenters, such as U.S. PIRG, suggest adding descriptions of the amount of growth by stating how large water beads can get, while Zach Gilbert suggests adding statistics to describe how the beads can expand to multiple times their original size (*e.g.*, percentage increase). Christian Beasley and Austin Watson suggest that the warning include language explaining that products can grow by absorbing water, other liquids, or body moisture, with one commenter, Austin Watson, stating that consumers might not recognize the potential for expansion after ear insertions, relative to ingestions, because the ear environment is seemingly dryer. Three commenters offer specific revisions to the initial sentence of the warning to address one or more of these growth-related issues. Christian Beasley suggests, “This product contains water beads that can grow larger when exposed to water or water-based fluids.” Mollie Price suggests, “This product contains water beads that [can] grow larger within the [human] body.” AAP suggests, “This product contains water beads that can grow much, much larger when the[*sic*] absorb water or any liquid. This includes bodily fluids if the beads are swallowed or placed in the nose or ears.”

Response: The Commission agrees that the first sentence of the warning labels in the proposed rule (Figures 3 and 4), which describe the growth of water beads, should be revised to

clarify that the expansion of these beads can occur within the body, specifically, after ingestion or insertion. To address the comments related to this concern, the final rule has revised this sentence in Figures 4 and 5 (renumbered) from “This product contains water beads that grow larger,” to, “Contains water beads that can grow larger when swallowed or inserted in the ear or nose.” The Commission does not agree that specifying the precise amount by which the beads can grow is necessary, given that the subsequent sentence already communicates this information qualitatively by stating that they have blocked intestines. The Commission also concludes that specifying that growth can occur when exposed to liquids other than pure water or to body moisture is unnecessary, because the warning labels’ revised language now explicitly states that growth can occur “when ... inserted in the ear or nose.” The lack of this information in the NPR warnings was the basis for the commenters’ suggestions for including information about other bodily fluids. By adding ear and nose insertions to the hazard identification sentence, the Commission also addresses concerns from commenters that references to ear and nasal insertions were not sufficiently prominent by being mentioned only at the end of the warning labels.

b. References to death

Comment: Max Williams, Ryan Jernigan, Kirksey Croft, and one anonymous commenter express concerns about the warning labels’ reference to death and use of the phrase, “Your child can die too.” Max Williams and Kirksey Croft suggest that emphasizing deaths in the warnings is inappropriate, especially in comparison to warnings for other hazards, such as choking, that are associated with more fatalities but do not explicitly refer to death. Max Williams also notes that deaths are very rare, with only one known death involving water beads. Max Williams and Ryan Jernigan describe the phrase, “Your child can die too,” using terms such as paternalistic, inflammatory, alarmist, and fearmongering, and claim that this phrase could lead consumers to either ignore the statement or to no longer take warnings seriously. An anonymous commenter states that the phrase, “Your child can die too,” is redundant with the preceding sentence, which already addresses the potential for death. Generally, commenters on the phrase, “Your child can

die too,” recommend its removal. However, Eleanor Grundberg refers to this phrase in more positive terms, stating that it will likely grab the attention of consumers, and Daniel Mendoza suggests that this phrase “emphasizes the urgency of the hazard and is likely to resonate with caregivers.”

Response: The warning labels’ reference to death is appropriate given the known potential consequences of ingesting water beads. However, the use of the phrase, “Your child can die too,” is unnecessary given the already-explicit reference to death in the warnings and the relative rarity of fatalities, which presumably will become even more rare as the performance requirements of the rule go into effect. The phrase, “Children have DIED,” already emphasizes the urgency of the hazard and is likely to motivate consumers to act. Thus, the phrase, “Your child can die too,” has been removed from the warnings shown in Figures 4 and 5 of the final rule. Additionally, the sentence describing how children have died has been revised in Figures 4 and 5 to be more concise by changing the phrase, “after swallowing water beads because the beads blocked,” to “when the beads blocked,” because the initial sentence of the final rule’s warnings already identify swallowing explicitly.

c. Additional ingestion-related information

Comment: Eleanor Grundberg, Ryan Jernigan, Zach Gilbert, and U.S. PIRG suggest that the warning include additional details related to the ingestion hazard. Ryan Jernigan, Zach Gilbert, and U.S. PIRG suggest that the warning refer to hospital-related treatments, such as hospitalization statistics or the potential for emergency surgery. Eleanor Grundberg suggests that the warning include the following language about the symptoms of intestinal blockages, to reduce the potential for misdiagnosis by parents: “This product may cause lethargy, distress, dehydration, loss of appetite, fever, fatigue, and abdominal pain when an expanded water bead blocks the small intestine.” Jacob Lowe suggests that all toys that have acrylamide should have a warning label.

Response: We disagree with commenters suggesting that the warnings refer to hospital-related treatments resulting from ingestions. Although ingestion-related hospitalizations and other non-fatal consequences are more common than fatalities, the potential for death from ingestions is likely to be a stronger motivator for consumers and is highlighted in the warning labels. However, we agree that there would be value in addressing the potential for hospital-related treatments in the context of ear and nose insertions, and this is discussed below in response to comments about non-ingestion hazards.

The Commission appreciates the comments about adding language regarding the symptoms of intestinal blockages but concludes that adding this information to the warning is not appropriate at this time. The intent of the warning labels is to identify the ingestion and insertion hazards and to instruct consumers about how to avoid them. Prioritizing and limiting the information to be included on a warning label is important to hold, or maintain, a consumer's attention after the warning has been noticed, and the symptoms of intestinal blockages are not especially diagnostic, in that they do not point consumers to a single, unambiguous cause (*i.e.*, ingested water beads). Thus, although additional information about potential symptoms could be useful, this information would be more appropriate for manufacturers to consider including within the instructional literature rather than on the warning labels. Finally, regarding Jacob Lowe's suggestion of applying warning labels to all toys containing acrylamide, this comment is outside of the scope of the rulemaking. However, if the Commission finds evidence of hazards presented by acrylamide in toys other than water beads in the future, then regulatory activity may be considered.

d. Non-ingestion hazards

Comments: Kayla O'Connor, Caitlin Slusarski, Kayla O'Connor, Christian Beasley, Jake Peterson, John Oldham, Albert Tacornal, Austin Watson, Zach Gilbert, Consumer Reports, and four anonymous commenters suggest not limiting the hazard and consequence information in the warnings to the ingestion hazard, and to include information related to other water-bead hazards.

Many comments emphasize the need for information on ear and nose insertions and on inhalations or aspirations. Mollie Price and Austin Watson identify particular consequences of interest related to insertions, including deafness or permanent hearing loss, invasive surgery, and seizures. Another commenter, John Oldham, suggests the following language about the insertion and inhalation hazards: “If inhaled into the lung, this product can cause unconsciousness and the inability to deliver oxygen to the brain; if inserted into the ear, this product can damage ear structure or hearing loss; and if inserted into the nose, this product can cause bleeding, fever, or nasal swelling.” Caitlin Slusarski, Austin Watson and Zach Gilbert suggest that the warnings address other hazards such as the choking hazard and the toxicity of water beads. An anonymous commenter suggests adding language to describe the water beads’ carcinogenic properties or the potential for acrylamide toxicity. Christian Beasley also suggests the following warning: “Water beads are composed of absorbent polymers, which can contain acrylamide monomer—a chemical that can be hazardous when ingested.” Consumer Reports suggests restricting the ability of manufacturers to use the term “non-toxic” in their labeling.

Response: The Commission agrees with commenters that the hazard description in the warnings for water beads should not be limited to the ingestion hazard, given the frequency and potential severity of the insertion hazard. As discussed earlier, the final rule has revised the initial sentence of the warnings in Figures 4 and 5 (renumbered from Figures 3 and 4 in the proposed rule) to state that beads also can grow when “inserted in the ear or nose.” In addition, the warnings in the final rule add information describing the potential consequences of the insertion hazard. Specifically, after the sentence describing the potential for death from ingestions, the warnings in Figures 4 and 5 of the final rule add the sentence, “Inserted beads have resulted in surgeries.” This addition is consistent with commenters’ request for information pertaining to the other primary hazards and is broad enough to encompass different types of insertions without adding unnecessarily lengthy text. As noted previously, prioritizing and limiting the information presented on a warning label is important to improve the likelihood that

consumers will fully read and attend to the most important safety information in the warning. The Commission assesses that including information about aspirations would be more appropriate to include in the instructions, rather than in the warning labels. The Commission also finds it unnecessary to add language about the beads' carcinogenic properties or the potential for acrylamide toxicity because of the limit in the rule on the amount of allowable acrylamide in water bead toys—a limit that is intended to address the toxicity hazard directly.

e. X-ray visibility

Comment: Elizabeth Berdan, CFA, That Water Bead Lady, and one anonymous commenter suggest adding language to the warning labels stating that water beads often do not appear on an x-ray. Elizabeth Berdan recommends the following specific language: “This product is not visible on x-rays, which may delay diagnosis and treatment.” As noted later, in the summary and response to comments related to instructional literature, That Water Bead Lady and NASPGHAN suggest that the package insert, or instructional literature, include information about water beads not appearing on an x-ray.

Response: The Commission acknowledges that it might be helpful for consumers who suspect that their child has ingested water beads to know that water beads are not easily visible on x-rays. However, the Commission disagrees with adding this information to the warning labels in the final rule. This information, like the information on ingestion symptoms described earlier, would be more appropriate provided within the instructional literature. This approach allows the warning labels to focus on and highlight the most critical safety information about water beads, increasing the likelihood that consumers will fully read and understand this warning information.

2. Additional Hazard-Related Revisions

Comment: Three commenters offered the following specific revisions to the initial sentences that describe the hazard and consequences. Elizabeth Berdan suggests:

“DANGEROUS IF SWALLOWED. This product contains water beads that can cause life-

threatening bowel obstructions, especially at narrow points like the ileocecal valve.” Albert Tacornal suggests: “This product uses water beads, a known hazard. Water beads expand and, if ingested, can cause serious injury or death.” Ryan Jernigan suggests: “Water Beads Expand When Ingested and May Shatter—Potentially Fatal.”

Response: As discussed earlier, the Commission has revised the warning language in Figures 4 and 5 of the final rule to clarify the hazards and consequences associated with water bead products. These revisions address most of the commenters’ specific suggestions and concerns about water beads expanding within the body and the potential for death. The Commission disagrees with adding language that explicitly identifies the “ileocecal valve,” as this term is unlikely to be understood by the general population and is not necessary for consumers to understand the ingestion hazard. In response to the comment suggesting warning language about water beads shattering, there is no evidence that the hazard associated with water beads stems from the beads breaking down or “shattering” within the body. Rather, consistent with the final rule warnings, the primary hazard involves intact, expanded water beads being unable to pass naturally through the gastrointestinal tract and causing an obstruction.

3. Warning Content: Hazard Avoidance

a. Discard statement

Comment: Jared Shelton, Briana Zimmerman, Eleanor Grundberg, Christian Beasley, Albert Tacornal, Austin Watson, AAP, and CFA express concerns about, or proposed clarifying revisions to, the warning statement to discard the product if the water beads are coming out. Jared Shelton, Eleanor Grundberg, Christian Beasley, AAP, and CFA assert that the current statement is vague, open to interpretation, or confusing, and requires clarification. Jared Shelton, Eleanor Grundberg, and Christian Beasley focus on the phrase “coming out,” stating that it is unclear how many beads need to have exited, whether the beads must be continually leaving or flowing out of the product, or whether the beads are coming out of the product or the child. Christian Beasley suggests changing the phrase “coming out” to “exposed,” which purportedly

emphasizes that the beads are unshielded or unprotected. Other commenters offer the following specific revisions to the discard statement. Jared Shelton suggests: “If internal beads become accessible for any reason discard the product immediately.” Briana Zimmerman suggests: “Discard if beads become separated from the body of the toy,” or “Discard if beads are no longer within the toy cavity.” AAP suggests: “Discard if the beads are leaking out of this product”; alternatively, “leaking out” could be replaced with “exposed,” “visible,” “dislodged,” or “accessible.” CFA suggests: “Discard if the beads are or become accessible.”

Albert Tacornal and Austin Watson suggest that in addition to discarding the product, consumers should be told to search for loose water beads that children could ingest. Albert Tacornal suggests the following language in their comment: “... ensure no loose beads can be picked up and swallowed by children.”

Response: The Commission agrees with commenters that the statement, “Discard if beads are coming out,” in Figure 4 of the proposed rule, is open to interpretation and potentially confusing. For improved clarity, the Commission has revised this statement in Figure 5 (renumbered from Figure 4) of the final rule to say, “Discard product if beads start to come out.” This revision clarifies that the statement is referring to the beads coming out of the product—thus, the need to discard the product, not just the beads—and that the product should be discarded as soon as any beads start to come out, rather than the beads having to be flowing out of the product. The Commission concludes that adding language that instructs consumers to seek out loose water beads is not needed, as this would increase the length of the warning, without presenting a clear additional benefit. Calling attention to beads coming out of the product, combined with the earlier information in the warning about the hazardousness of the beads and the potential for death, should be sufficient to motivate consumers to look for loose beads in the environment.

b. Minimum age

Comment: Elizabeth Berdan, Porter Spell, Han Lemberg and Caroline Divver suggest adding more specific age-related information to the warnings, either in terms of what ages should be prohibited from playing with these products or the age at which play with these products would be appropriate, but the recommendations varied. For example, Elizabeth Berdan suggests, “DO NOT ALLOW CHILDREN UNDER 9 YEARS TO HAVE ACCESS TO THIS PRODUCT.” Han Lemberg suggests, “Children ages 0-3 should never play with water bead toys.” Caroline Divver suggests that the warnings state that children under 3 should never be permitted to play with water bead toys.

Response: The warning labels in Figures 4 and 5 of the final rule already include qualitative age-related information in the form of the statement, “Keep away from babies and toddlers,” to highlight those children most at risk. The commenters have not provided a basis for more specific numeric age recommendations, and there appears to be no consensus among these commenters about the appropriate age. Thus, the Commission declines to add more specific age-related information to the warning labels in the final rule.

c. Sensory toys

Comment: Briana Zimmerman and Max Williams express concern about the NPR warning’s reference to sensory toys, stating that it is unclear what constitutes, or what uses would classify a product as, a “sensory toy,” or that the reference to sensory toys could confuse or mislead consumers. Briana Zimmerman states that the common use of sensory toys by neurodivergent children, and the marketing of these products for these children, could lead consumers to conclude that water beads do not pose a danger to neurotypical children. Max Williams suggests the following possible revisions to the warning statement about sensory toys: “Do not use in sensory toys for children under 5 years of age,” or “Not for use in sensory toys that are put in the mouth.”

Response: The Commission shares commenters’ concerns about potential confusion surrounding what constitutes a sensory toy. In addition, staff’s concerns about the use of water

beads as sensory toys or bath toys were based on such uses being common among young children. The warning labels in the rule already explicitly warn to keep water beads away from babies and toddlers, making the precaution against the use of these products as sensory or bath toys redundant. Thus, to improve the likelihood of consumers reading the full warning content by further limiting the length of the warnings and the amount of potentially unnecessary content that could distract from the most important safety information, the final rule removes the bullet statement, “Never use as a sensory toy or bath toy,” from the warning labels in Figures 4 and 5.

d. Supervision

Comment: Daniel Mendoza, Max Williams, Mollie Price, and Austin Watson suggest adding content about monitoring or supervising the child during play with or while in the presence of water beads, with Max Williams adding that supervision is especially important for children who are on the cusp of toddlerhood.

Response: Supervision is one method of preventing childhood injuries. However, there is agreement in the literature³⁵ that caregivers cannot be perfectly attentive during their child’s entire awake time, particularly if multiple children are present. Ingestion and insertion incidents can happen in a matter of seconds, meaning consumers might be unaware that an incident has occurred. Consumers also might witness an ingestion and not act, believing that the water bead will simply pass through the digestive tract. Thus, the Commission assesses that adding supervision to the warning label is unlikely to be very effective at preventing incidents.

Nevertheless, the Commission agrees that there is value in adding a brief statement about supervision, given its important role in injury prevention. Thus, the warning labels in Figures 4 and 5 of the final rule add the new statement, “Watch older children during use,” immediately after the statement, “Keep away from babies and toddlers,” a phrase that already identifies a

³⁵ Morrongiello, B. A., Corbett, M., McCourt, M., & Johnston, N. (2006). Understanding unintentional injury-risk in young children I. The nature and scope of caregiver supervision of children at home. *Journal of Pediatric Psychology*, 31(6): 529–539; Morrongiello, B. A., Corbett, M., McCourt, M., & Johnston, N. (2006). Understanding unintentional injury-risk in young children II. The contribution of caregiver supervision, child attributes, and parent attributes. *Journal of Pediatric Psychology*, 31(6): 540–551; Wickens, C. D., & Hollands, J. G. (2000). *Engineering Psychology and Human Performance* (3rd Ed.). Upper Saddle River, NJ: Prentice Hall (pp. 714-715).

vulnerable population and implies that careful attention is warranted. The additional statement, “Watch older children during use,” not only emphasizes the importance of monitoring children’s use of water beads, but the reference to older children avoids the potential for consumers to conclude that only infants and toddlers are at risk.

e. Limiting access

Comment: Ayden White and Daniel Mendoza suggest adding information related to limiting children’s access to water beads. Ayden White suggests adding instructions for proper water bead storage. Daniel Mendoza suggests that the warning could instruct consumers to keep water beads out of children’s reach.

Response: The Commission agrees with limiting young children’s access to water beads. However, the warning statement, “Keep away from babies and toddlers,” in Figures 4 and 5 of the rule, already clearly communicates this information. Adding information about storage and the use of child-proof containers to the warning label would potentially distract consumers from the most critical safety information about water beads, thereby reducing the likelihood that consumers will fully read and understand the warnings, and is not appropriate, as consumers are unlikely to have child-resistant containers readily available for this use.

f. Teach not to mouth

Comment: Daniel Mendoza suggests adding an instruction to the warnings that directs consumers to teach children not to place objects in their mouths.

Response: Children place non-food items into their mouths for several developmentally appropriate reasons. For example, young children learn about texture, shape, and taste through mouthing, and during teething, children naturally attempt to soothe the discomfort of tooth eruption by mouthing objects. Mouthing objects is a form of childhood education by teaching children what is safe to place in the mouth, and it is a natural part of a child’s curiosity and imitation play. Through mouthing, children learn what items they can or cannot eat. In light of this, it is unrealistic to expect warning language that instructs caregivers to teach children not to

put objects into their mouths to be effective in preventing water bead ingestions. Therefore, the Commission declines to add such an instruction to the warnings.

4. Warning Content: Pictograms or Graphics

Comments: Michael Ravnitzky, Han Lemberg, Christian Beasley, Caroline Divver, Christopher Cochran, and Zach Gilbert suggest adding pictograms, icons, or similar graphical elements to the warning to convey the hazard. The commenters suggest that these graphics would help to capture attention and would improve understanding of the hazard among non-English-speaking households or those who cannot read, including children. Christopher Cochran suggests that ANSI Z535.4 emphasizes the use of such graphics, paired with text. Han Lemberg specifically recommends adding a graphic depicting the ingestion risk. Zach Gilbert suggests the use of a visual representation of a water bead growing and obstructing the intestines.

Response: The use of pictograms and icons is one common method of communicating safety information and enhancing attention to warnings, and the Commission acknowledges that, in principle, the use of such graphics could help those not capable of reading English. However, staff are not aware of any pictograms or similar graphics that accurately and effectively portray the hazards associated with water beads. Designing effective graphics to address a specific hazard can be challenging. Even seemingly obvious or intuitive graphics may be misunderstood and lead to misinterpretation, including the possibility of interpretations that are the opposite of the intended meaning. To minimize confusion, warning pictograms should be developed based on empirical research and thoroughly tested with the intended audience. Based on the above, the Commission declines to add pictograms to the warning labels in the final rule.

5. Warning Content: Multilingual Labels

Comment: Han Lemberg asserts that warnings should be provided in both English and Spanish to ensure that the largest number of consumers can understand the warning.

Response: The warnings on products sold in the United States must be written in English. There are no mandatory requirements for warnings and packaging information to be presented in

multiple languages, but the Commission acknowledges that this is a common practice within the industry. The Commission recognizes the potential usefulness of providing warnings in multiple languages and does not discourage their use if the language is first presented in English.

However, the Commission will not impose a mandatory requirement that departs from the traditional approach of only requiring warnings in the English language.

However, consistent with the commenter's expressed goal of ensuring that the largest number of consumers can understand the warnings, several changes to the warning language for the final rule that have been discussed previously (*e.g.*, changes to the hazard descriptions and consequences, changes to the "discard" statement) have simplified and clarified the content of the warning language. To further improve the likelihood that most consumers, including those with limited English literacy, will be capable of understanding and acting on the warnings, the warning labels in Figures 4 and 5 of the final rule revise the phrase, "Seek immediate medical attention," to the simpler and more plain-language wording, "Get medical help right away." This change should assist in ensuring that the largest number of consumers can understand the warning.

6. Warning Format

a. Highlighting specific text

Comment: Kayla O'Connor, Jake Peterson, Caroline Divver, and Austin Watson suggest formatting changes to highlight certain text in the warning. Kayla O'Connor and Jake Peterson suggest using boldface text to highlight references to ear insertion, nasal insertion, and aspiration. Caroline Divver suggests using boldface text for the statement "seek immediate medical attention." Jake Peterson and Austin Watson suggest moving certain text, with Jake Peterson suggesting moving the bullet item about insertions and aspirations earlier, and Austin Watson suggesting moving the statement about discarding products with water beads into the bullet list. The latter commenter states that this change was needed because the statement is a

hazard-avoidance statement, and its current placement, in non-boldface text, interrupts the descriptions of the hazard and its consequences, making it less likely to be read.

Response: The Commission agrees with commenters about the importance of highlighting key information in warnings and has formatted select text in Figures 4 and 5 of the final rule, such as the phrases, “Discard product” (Figure 5 only), and “Get medical help right away” (both figures) in boldface. As discussed earlier, the Commission has relocated information about the hazards associated with ear and nose insertions to earlier in the warning. The statement about discarding water beads has been moved into the bullet list of the warning label shown in Figure 5 of the final rule, with other preventative, or hazard-avoidance, behaviors.

b. Size of label elements

Comment: Zach Gilbert suggests increasing the overall size of the label, enlarging the type sizes, and increasing the size of the “warning marker,” which the Commission interprets as meaning the signal word panel, to better capture consumer attention.

Response: The warning labels in the final rule are designed to be consistent with ANSI Z535.4, the primary U.S. voluntary standard for the design of product safety signs and labels, to attract consumers’ attention using features such as color, a safety alert symbol and signal word “WARNING,” a surrounding border, and key information highlighted in boldface type. The size of the signal word panel follows requirements outlined in section 5.3 of ASTM F963 and is consistent with other toy warning labels. Thus, the warnings’ visual elements should be readily visible and noticeable to consumers, particularly given the requirement for the warnings to be located on the principal display panel of the product package. The Commission declines to make changes to the size of the warnings or their individual elements in the final rule based on this comment.

7. Warning Placement

Comment: Christian Beasley and Jake Peterson assert that the warning should appear in a prominent location on the front of the package, while Jake Peterson contends that the warnings

also should be available online where the products are purchased. Albert Tacornal recommends that warnings appear on containers of water beads, not on products that use water beads, because the containers are the source of the risk and the products that use them will likely be discarded without the warning being read.

Response: The final rule requires warning labels to be on the principal display panel of the toy packaging, where it is most likely to be seen by consumers. If the water beads are packaged in a separate container, the warning label is required on its principal display panel. Additionally, if there is not enough space available on the packaging, or there is no packaging, manufacturers can use a hangtag containing the required warning label as permitted in section 1250.4(d)(1)(iii) of the rule. Regarding online warning labels, section 105 of the CPSIA requires cautionary statements for small parts, balloons, marbles and small balls on any advertisements including internet websites, catalogs, or other printed material where a toy is offered for purchase. CPSC supports online warning labels generally for toys but is not requiring them in this rule because a holistic approach to developing online warning label requirements for toys would be more efficient than just addressing the issue in this rule. Therefore, staff plans to recommend that the ASTM F15.22 Subcommittee's Emerging Hazards Task Group consider the development of general requirements for online warning labels for toys for inclusion in ASTM F963.

8. Warning Effectiveness

Comment: Eleanor Grundberg notes that the NPR acknowledges the lesser effectiveness of warnings compared to designing out a hazard or guarding consumers from a hazard. The Toy Association asserts that warnings for water bead toy products are neither appropriate nor required because the performance requirements address the potential for intestinal obstruction. Albert Tacornal argues that warnings are unlikely to be effective in dissuading consumers from purchasing these products and are unlikely to increase supervision, and that previously issued warnings about these products appear to be ineffective because incidents continue. Albert

Tacornal also states consumers may be indifferent to yet another warning because they are already inundated with warnings. Savannah Mesel asserts that warnings are not effective in preventing accidents among young children who lack the ability to understand the danger. This commenter further explains that although warnings can help parents or caregivers understand, they cannot prevent child exposure, even with supervision, as demonstrated by current supervision practices in the incident data and research that shows toddlers are often out of sight for brief periods during play. The commenter also notes that caregivers also may underestimate the danger, particularly if the products are marketed as safe for children's sensory play. Eleanor Grundberg states that the proposed warnings may offer a benefit by reducing the time between ingestion and treatment.

Response: The Commission agrees that providing warnings and instructions about hazards is less effective at eliminating or reducing exposure to hazards than either designing the hazard out of a product or guarding the consumer from the hazard. This is the basis for the performance requirements in the final rule that are intended to reduce the likelihood of intestinal obstructions if water beads are ingested. Nevertheless, the Commission recognizes that the performance requirements alone may not fully address the potential for intestinal blockages after ingestion, given anatomical variations among children and the likelihood of variance in water bead sizes during manufacturing. The rule's performance requirements are engineered to minimize injury associated with water beads being inserted in the ears, nose, or other parts of the body. By contrast, the warning labels and instructions are intended to supplement the performance requirements by increasing consumer awareness of the hazards associated with water beads and potentially reducing young children's exposure to these products. Therefore, performance requirements and warning labels and instructions are complementary, not an exclusive way to address a hazard.

9. Instructional Literature

Comment: Consumer Reports and one anonymous commenter express support for the proposed instructional literature requirements, with one of the anonymous commenters stating that they are adequate and efficient. Daniel Mendoza suggests that the instructional materials follow ANSI Z535.4. Other commenters suggest that various information be included in packaging inserts, or instructional literature. Specifically, NASPGHAN and That Water Bead Lady suggest including information stating that ingested water beads will not appear on x-rays, which will enable consumers to convey this information to health care providers. Caitlin Slusarski suggests including information about all the hazards associated with water beads. An anonymous commenter suggests including information about the use and storage of water beads. An anonymous commenter suggests including information about what to do if water beads are accidentally ingested. Mollie Price suggests including information about supervision, if not included in the warning itself. The Toy Association suggests including cautionary information about ear and nose insertions.

Response: The rule requires the instructional literature, when provided, to include the same warnings that must appear on the product packaging, which is required to be formatted consistent with certain sections of ANSI Z535.4-2023, with modifications. Instructional literature is required to meet those same formatting requirements, but without the use of color, provided the warnings contrast with the background of the instructional literature. The revised warning labels in the final rule include more comprehensive and explicit information about the ingestion and insertion hazards, so the instructional literature will include this more detailed information. As suggested by commenters and mentioned previously, the instructions are an appropriate place to add additional product safety information, such as water beads not being easily visible on x-rays, ear insertions leading to hearing loss, nose insertions leading to surgical extraction, and storage instructions. For reasons discussed previously, the Commission is not requiring such information to be required on the warning label in the final rule. However,

manufacturers may choose to include such information, if desired. Additionally, the Commission notes the warning label in the final rule already includes some of the information being sought by commenters, such as information about supervision and the need to “[s]eek medical attention” if water beads are ingested, and as noted earlier, this information is required to be in the instructional literature that accompanies these products.

10. Labeling Exemption

Comment: Intertek Shenzhen asks if the size of the toy is too small, could the labeling requirement on toy be exempted.

Response: As noted in the preamble of the NPR (89 FR 73049) and § 1250.4(d)(1)(iii) of the rule, if there is not enough space available on the packaging, or there is no packaging, manufacturers can use a hangtag containing the required warning label.

E. Other Recommendations

1. Proposed Language Changes to Codified Text

Comment: Michael Ravnitzky contends there are several areas where the rule could be improved or clarified by increasing the use of plain language. He notes, in the NPR §1250.4(a) says: “This section establishes performance and labeling requirements for water bead toys and toys containing water beads to minimize the risk of children ingesting, inserting, aspirating, and choking on water beads.” The commenter suggests instead: “This section sets performance and labeling rules for water bead toys to reduce the risk of children swallowing, inhaling, or choking on water beads.” The commenter also makes several other suggested modifications to definitions, where modifying language would improve clarity.

Regarding aspiration hazard, the NPR proposes: “Aspiration hazard means a hazard caused by a child inhaling a water bead whereby the water bead can become lodged in the respiratory tract and can potentially cause death or injury.” The commenter suggests instead: “Aspiration hazard: This occurs when a child inhales a water bead. The bead can get stuck in the respiratory tract, causing injury or death.”

Regarding choking hazard, the NPR proposes: “Choking hazard means a hazard caused by a child attempting to swallow a water bead whereby the water bead can become lodged in the throat and can potentially cause death or injury.” The commenter suggests instead: “Choking hazard: This occurs when a child tries to swallow a water bead. The bead can get stuck in the throat, causing injury or death.”

Regarding ingestion hazard, the NPR proposes: “Ingestion hazard means a hazard caused by a child swallowing a water bead whereby the water bead can become lodged in the digestive tract and can potentially cause death or injury.” The commenter suggests instead: “Ingestion hazard: This occurs when a child swallows a water bead. The bead can get stuck in the digestive tract, causing injury or death.”

Regarding insertion hazard, the NPR proposes: “Insertion hazard means a hazard caused by a child putting a water bead in the ear canal or nasal passage of the body and can potentially cause injury or death.” The commenter suggests instead: “Insertion hazard: This occurs when a child puts a water bead in the ear or nose. The bead can cause injury or death.”

Response: None of the commenter’s suggestions improve clarity. Instead, these suggestions only repeat the proposed language, but with reduced and synonymous language. Therefore, the Commission is not modifying the language in the final rule based on the comment.

2. Bitterants

Comment: Bindi Naik-Mathuria, Porter Spell, Brianna Zimmerman, John Oldham, Ryan Jernigan, Connor Mitchell, AAPS, and That Water Bead Lady suggest requiring water beads be made unpalatable, with the use of a bitterant. The commenters assert that although adding a bitterant would not prevent children from putting the water beads in their mouth initially, it may prompt them to reject the water bead.

Response: The Commission declines to add a bitterant requirement to the final rule. The Commission concludes that bitterants generally are not effective in deterring ingestions. Real

world investigations have not demonstrated that bitterants are effective at preventing ingestions.³⁶ Bitterants do not deter initial ingestion because the user has not yet tasted the bitterant. This makes bitterants ineffective at protecting users from harm that can result from a single ingestion. A single water bead can result in an intestinal obstruction that requires medical intervention to resolve. Researchers also found that in adults, between 15 percent to 30 percent do not detect the taste of bitter compounds.^{37,38,39} Additionally, bitterants would not prevent ear and nose insertions.

3. BPA Limits

Comment: Consumer Reports states that CPSC should consider whether limits for bisphenol A (BPA), a known endocrine disruptor that has been linked to certain cancers and fertility issues, should be included in the final rule. The violative level would have to be determined to be included. In 2023, Consumer Reports tested several brands of water beads for known toxic chemicals, including lead, phthalates, and BPA, and found BPA in six brands of water beads.

Response: A BPA limit was not proposed in the NPR and is not included in the final rule. Proposing a limit on BPA would not be warranted at this time for the following reasons: (1) CPSC is not aware of any incidents involving or alleging BPA as an acute health hazard in water beads; (2) staff have no information on the levels of BPA found in the 2023 Consumer Reports study or the methods that were used to measure BPA; (3) staff have not established a method for measuring extractable BPA from water beads; (4) the toxicity concerns for BPA are associated with long-term, repeated or continuous exposure, which is not how incident data indicates children are exposed to water beads; (5) the acute toxicity of BPA appears to be relatively low; and (6) currently no federal agency has established an acute toxicity reference value for BPA.

³⁶ (CPSC, 1992). CPSC (1992) Final Report Study of Aversive Agents.

³⁷ *Id.*

³⁸ (NIDCD, 2010). Global Variation in Sensitivity to Bitter-Tasting Substances (PTC or PROP) | NIDCD (nih.gov).

³⁹ (NIDCD, 2019). Quick Statistics About Taste and Smell | NIDCD (nih.gov).

Additionally, CPSC has not committed resources to research and derive an acute acceptable daily intake for BPA. If staff find evidence of hazards presented by BPA contained in water beads in the future, then regulatory activity may be considered.

4. Child Resistant Packaging

Comment: Elizabeth Berdan and John Oldham recommend that toy manufacturers should be required to use child-resistant packaging to minimize the risk of accidental ingestion by young children.

Response: Staff does not expect child-resistant packaging requirements to be an effective deterrent because the hazard pattern for water beads shows they can be lost and picked up off the ground and ingested at a later time. Additionally, once water beads are expanded, it is unlikely that adults would reuse the same child-resistant package because the expanded water beads would no longer fit in the child-resistant package. Before expanded water beads would fit in the child-resistant package, they would need several hours to dehydrate and shrink back to their original size.

5. Regulate Marketing

Comment: Elizabeth Berdan and U.S. PIRG suggest prohibiting the marketing of expanding water beads for children's use. Consumer Reports urges the agency to monitor how water bead products are marketed as they expect manufacturers to repurpose and remarket water bead products as non-toys. Porter Spell and Jannah Hancock recommend a minimum age be set for any item containing water beads.

Response: This rulemaking is being conducted pursuant to CPSIA section 106, and CPSC does not have the authority to prohibit the specific marketing of water beads to children or to enforce minimum age requirements. However, if CPSC finds non-toy water bead products that are designed, manufactured or marketed for children under age 14 years old, then the water bead product will be considered a toy and within scope of this rule, and thus subject to its requirements.

6. Ship Water Beads Fully Saturated

Comment: Ryan Jernigan asserts that the Commission should mandate manufacturers fully saturate water beads during production. While the Commission proposes implementing standards that limit the ability of water beads to expand, saturating the water beads fully before they reach the market may prove to be a simpler and more effective solution.

Response: The commenter's suggestion would not be effective. Over time, when not immersed in water, water beads shrink back to their original size. If manufacturers ship the water bead toys fully saturated, so the water beads arrive fully expanded, the consumer will likely take the water beads out for play and the water beads will eventually dehydrate and shrink. The shrunken water beads would then pose a hazard to a child if a child were to swallow one of the shrunken water beads. There is no guarantee that the water beads would be placed back in water, to keep them expanded, when not in use. Thus, the commenter's recommendation would not be effective in mitigating the hazards that water beads pose to children.

7. Make Ingested Water Beads Detectable

Comment: Porter Spell and Christopher Cochran suggest making water beads detectable by doctors such as making water beads able to show up on x-ray technology or other imaging techniques.

Response: Staff are unaware of methods of making water beads detectable through x-ray scans due to their composition. As stated in the preamble of the NPR (89 FR 73029), water beads are not easily identified using routine x-ray radiography because they are not dense, appearing dark or black and almost entirely transparent when the x-ray beam passes through the water bead. Incident data and medical literature report children requiring serial x-rays, computer tomography (CT) scans, and ultrasounds to diagnose a water bead bowel obstruction.

8. Durability Testing

Comment: Christopher Cochran and Emily Threatt suggest the Commission should consider including stricter tests for durability. Stricter durability testing would likely ensure that

water beads do not break into smaller, more ingestible pieces. Ryan Jernigan recommends a reevaluation of materials used in making water beads, if water beads shatter upon compression.

Response: The ingestion hazard pattern presented by water beads is children ingesting whole water beads, not water beads breaking up and then children ingesting those pieces. Additionally, if fully expanded water beads were to break into pieces, those pieces do not have the potential to grow any further. In other words, testing the whole, fully grown water bead is the most stringent test, so testing the expansion of detachable pieces is not necessary. Therefore, durability testing is not necessary.

9. Information and Education Campaigns

Comment: Ryan Jernigan and Medical Toxicology LLC suggest that CPSC should explore or engage in educational campaigns about the dangers of water beads to increase awareness and allow consumers to make informed decisions. Ryan Jernigan opines that public education can complement regulatory efforts by informing parents about the risks involved with these toys and encouraging vigilant supervision. Consumer Reports notes that such campaigns may help to educate consumers but are not enough.

Response: The Commission supports information and education campaigns about the dangers of water beads and agrees that such campaigns are important and useful. However, CPSC has provided public service announcements regarding the hazard presented by this product

and has issued unilateral warnings^{40,41}, safety warnings⁴², public safety bulletins^{43,44,45} and social media graphics.^{46,47} CPSC Commissioners have issued statements related to the topic.^{48,49,50} In addition, several health organizations and social media advocates have brought attention to the issue. Despite such campaigns, incidents continue, demonstrating that such campaigns are not sufficient on their own. The Commission agrees with Ryan Jernigan that information and education campaigns can complement regulatory efforts that include performance and labeling requirements to reduce the incidence of ingestion and insertion incidents with water beads.

10. Collaboration With Manufacturers

Comment: Ryan Jernigan and Daniel Mendoza opine that it might be beneficial for CPSC to consider a collaborative approach with manufacturers to develop safer alternatives to water beads. CPSC could also establish workshops or webinars that provide practical guidance on compliance strategies, product redesign, and best practices for ensuring safety while maintaining product integrity. Encouraging innovation in toy design could lead to the creation of expanding

⁴⁰ <https://www.cpsc.gov/Newsroom/News-Releases/2024/CPSC-Warns-Consumers-to-Immediately-Stop-Using-Jangostor-Water-Beads-Due-to-Chemical-Toxicity-Hazard-Violation-of-Federal-Ban-of-Hazardous-Substances-Sold-on-Amazon-com>.

⁴¹ <https://www.cpsc.gov/Newsroom/News-Releases/2024/CPSC-Warns-Consumers-to-Immediately-Stop-Using-Tuladuo-Water-Bead-Sets-Due-to-Chemical-Toxicity-Hazard-Violation-of-Federal-Ban-of-Hazardous-Substances-Sold-on-Amazon-com>.

⁴² CPSC Warns that Narcotics and Water Beads Are Growing Risks Facing Young Children (March 19, 2024) <https://www.cpsc.gov/Newsroom/News-Releases/2024/CPSC-Warns-that-Narcotics-and-Water-Beads-Are-Growing-Risks-Facing-Young-Children>.

⁴³ Water Bead Safety Education Page <https://www.cpsc.gov/Safety-Education/Safety-Education-Centers/Water-Beads-Information-Center>.

⁴⁴ Water Beads: A Danger to Young Children & Can Be Deadly if Swallowed Graphic <https://www.cpsc.gov/Safety-Education/Safety-Guides/Toys-Crafts-Water-Beads/Water-Beads-A-Danger-to-Young-Children-Can-Be-Deadly-if-Swallowed>.

⁴⁵ Water Beads Can Be Deadly If Swallowed Graphic <https://www.cpsc.gov/Safety-Education/Safety-Guides/Toys-Crafts-Water-Beads/Water-Beads-Can-Be-Deadly-If-Swallowed>.

⁴⁶ Instagram @USCPSC https://www.instagram.com/p/C4rVCGANJyS/?utm_source=ig_web_button_share_sheet.

⁴⁷ X.com @USCPSC <https://x.com/USCPSC/status/1702341499604648310>.

⁴⁸ Water Beads Can Cause Intestinal Obstruction and Lead to Death: Get Them Out of Your Home (Sept 13 2023) <https://www.cpsc.gov/About-CPSC/Commissioner/Richard-Trumka/Statement/Water-Beads-Can-Cause-Intestinal-Obstruction-and-Lead-to-Death-Get-Them-Out-of-Your-Home>.

⁴⁹ Chair Hoehn-Saric Statement on the Dangers that Water Beads Pose to Young Children (Sept 14 2023) <https://www.cpsc.gov/About-CPSC/Chairman/Alexander-Hoehn-Saric/Statement/Chair-Hoehn-Saric-Statement-on-the-Dangers-that-Water-Beads-Pose-to-Young-Children>.

⁵⁰ Statement of Commissioner Peter A. Feldman on Buffalo Games, LLC, Water Beads Recall (Sept 14 2023) <https://www.cpsc.gov/About-CPSC/Commissioner/Peter-A-Feldman/Statement/Statement-of-Commissioner-Peter-A-Feldman-on-Buffalo-Games-LLC-Water-Beads-Recall>.

materials that do not pose similar risks, thereby maintaining consumer interest while prioritizing safety.

Response: CPSC has been collaborating with manufacturers and other members of the public in a voluntary standard development setting for years to address the hazards of water bead toys. As stated in the preamble of the NPR (89 FR 73025), since 2009, CPSC has worked with the ASTM F15.22 Subcommittee Emerging Hazards Task Group to update the toy standard to address the hazards of water bead toys. The task group has discussed specific incident data and potential expansion limits for water bead toys, as well as the issue of acrylamide toxicity and water bead toys potentially containing high levels of acrylamide. The subcommittee has not, to date, published a standard that addresses the hazards presented by water bead toys. This includes the hazards presented due to expansion and acrylamide exposure.

11. Ban Water Beads Bills

Comment: Jake Peterson and NASPGHAN note that two bills have been introduced to Congress: H.R. 6468 (Ban Water Beads Act)⁵¹ and S. 4298 (Esther's Law)⁵² and that these are the best course of action to ensure children's safety.

Response: To date, neither of the two bills referenced by the commenters have been enacted into law. Therefore, as indicated by incident data, this rule is necessary in order to protect children from the risks of injuries from water bead toys.

F. Environmental Impact

Comment: Connor Mitchell asks whether CPSC is concerned that non-compliant water beads might be thrown away, further exacerbating the issues that plastic causes in our environment.

Response: As stated in the preamble of the NPR (89 FR 73045), there is little to no potential for affecting the human environment from the rule, and therefore, no environmental

⁵¹ <https://www.congress.gov/bill/118th-congress/house-bill/6468/text>.

⁵² <https://www.congress.gov/bill/118th-congress/senate-bill/4298/text>.

impact assessment is required for this rule. Additionally, non-compliant water beads do not have to be thrown away. Manufacturers and sellers can repack water bead toys to be sold for various non-toy purposes such as decorative purposes, air freshener products or deodorizers for cat litter, and in first-aid cold packs.

G. Data

Comment: Erin Brennan notes that the NPR suggests that there were 6,300 water bead related injuries seen in emergency departments from 2017 through 2022, but this number fails to differentiate between cases where actual harm to the child was recorded and visits that were merely precautionary, where no medical intervention was even necessary. The commenter asserts that if there were 6,300 cases of death or serious injury from these beads, then regulation may be necessary, but this is certainly not the case. Considering the actual risks involved in allowing children to play with water beads, the proposed regulations of these water beads are not justified.

Response: As stated in the preamble of the NPR (89 FR 73031), based on NEISS data, CPSC estimates 6,300 injuries related to water beads were treated in U.S. hospital emergency departments over the six-year period from 2017 through 2022. The disposition of those visits were as follows: 95 percent treated by a medical professional and released; 2 percent admitted for hospitalization; 3 percent held for observation; and less than 1 percent left without being seen. Given that 95 percent of these visits are categorized as being treated and released, staff cannot assume that these were all merely precautionary, where no medical intervention was necessary, as suggested by the commenter. Treatment could include multiple types of treatment depending on level of severity, including the administration of a scope or laxative.

H. Economic Impact

Comment: Corey Lee proposes the Commission reevaluate the per unit cost of the new packaging and labeling requirements. In his estimation, the unit cost seems to be arbitrarily set. The commenter asserts that no formula or methodology was presented as to how the Commission

came to the figure. He states that one can assume the Commission is relying on older data and may be unaware of the complexities in the graphic production process. He states that the new label could require a new graphics plate which can cost up to \$1,000. More costing data needs to be assessed from various packaging and labeling suppliers. Also, the estimation needs to include discussions about the potential production consequences and potential financial risks posed by the new labeling requirement.

Response: As stated in the NPR, firms might incur a small one-time additional cost from updating existing labels and/or adding labels. The preamble of the NPR (89 FR 73044) stated that costs associated with modifying or adding warning labels are low on a per unit basis because all manufacturers of children's products are already required to provide labels with their product pursuant to section 14(a)(5) of the CPSA. In the preamble of the NPR (89 FR 73044) staff estimated that the additional costs related to updating labels are less than \$0.01 per unit of product sold, which is a typical industry assumption with minor changes to labeling. However, staff did consider the commenter's high-end cost estimate for \$1,000 for a new graphics plate in its updated economic feasibility assessment for the final rule given the complexity for moisture resistant packaging with this product that the commenter described. Therefore, the main conclusion of economic feasibility assessment remains that the final rule is economically feasible but could incur significant costs to small businesses that may either drop out of the market or stop marketing their products as toys.

Comment: The Toy Association contends that the assertion that firms might incur a small, one-time additional cost from updating existing labels and/or adding labels is incorrect. While the incremental cost estimated in the NPR for an over label (separately applied stick-on label) might be at or close to the estimated cost for the application only, staff's estimates do not take into account the real costs associated with having to redesign the packaging to accommodate the additional label footprint, as well as the scrap costs for packaging already printed above and beyond the over label rework for product that is already contained in the previous packaging

version. Stating that all manufacturers of children's products are already required to provide labels with their product pursuant to section 14(a)(5) of the CPSA is also misleading, since the labels being referenced are not separate components as staff appear to be implying, but instead integrated labeling elements incorporated into the design and positioning of the printed packaging layouts. Any such change requires a redesign to re-align and re-arrange all the packaging layout elements, especially when the new label is large and in such cases, the entire sizing of the package layout may well need to be enlarged to accommodate the label, resulting in additional scrap costs as well as increased shipment costs since the physical volume of the packages increase accordingly.

Response: While the Toy Association did not provide specific cost information for staff consideration, staff did account for labeling cost to be as high as a one-time purchase of a graphic plate of \$1,000 in the economic feasibility assessment based on another comment. However, that cost estimate is likely an overestimate for manufacturers as the labeling requirements may be met in less expensive ways. If there is not enough space available on the packaging for the new label, manufacturers can use a hangtag warning label. In the preamble of the NPR (89 FR 73044), staff estimated the additional costs related to updating labels are less than \$0.01 per unit of product sold. Staff continue to expect the incremental cost related to the labeling provisions to be generally low for firms. The costs associated with modifying or adding warning labels are low on a per unit basis because all manufacturers of children's products are already required to provide labels with their product pursuant to section 14(a)(5) of the CPSA. Firms might incur a small one-time additional cost from updating existing labels and/or adding labels. Even with the consideration of higher labeling costs, the main conclusion of the economic feasibility assessment remains that the final rule is economically feasible but could impose significant costs on small businesses that may either drop out of the market or stop marketing their products as toys.

Comment: Jake Peterson notes that small businesses can be disproportionately affected by an overbroad regulatory environment. A recent study by the American Enterprise Institute found that more regulation yields more profits for larger firms while crushing smaller ones.⁵³ Therefore, it is likely that large toy companies may benefit from this regulation.

Response: The commenter's assertions are not specific to water beads and are not substantiated with data. Instead, the commenter references an op-ed article by Timothy P. Carney that discusses the results of a working paper by Shikhar Singla. Neither of these references are about the toy industry. The referenced working paper does not review any regulations from the CPSC to estimate regulatory costs by regulatory agencies, nor does it rely on data from any large toy companies. The author of the working paper reviewed data from the Environmental Protection Agency, National Highway Traffic Safety Administration, Energy Department, Interior Department, Justice Department, Health and Human Services Department, Labor Department, Agriculture Department, Defense Department, and Homeland Department. The working paper references commercial package air conditioning and heating equipment, commercial warm air furnaces, automobile manufacturing, and light truck/utility vehicle manufacturing, which are not similar to the topic of the NPR.

In the preamble of the NPR (89 FR 73042) and unchanged for the final rule, staff assessed the rule likely would have a significant economic impact on a substantial number of small entities supplying the water bead toy market, primarily from redesign costs in the first year that the rule would be effective. Specifically, a significant impact likely would occur for small companies whose products do not meet the requirements of the rule. However, it is important to note that CPSC has enforced ASTM F963 as a mandatory standard for toys since 2009 and the existing section 4.40 *Expanding Materials* of ASTM F963-23 includes requirements for toys, including but not limited to water beads, that are made of expanding materials. Therefore,

⁵³ Timothy Carney, *More Regulation Yields More Profits for Large Firms While Crushing Small Ones: Study* Op-ed, Washington Examiner (2023).

certain costs, as mentioned in the preamble of the NPR (89 FR 73042), should not be new significant costs for most small firms, given suppliers should already test to the current mandatory standard. As stated in the preamble of the NPR (89 FR 73044), staff expect that small manufacturers likely would incur significant costs from redesign, retooling, loss of product sales, and material changes to comply with the rule.

Comment: Connor Mitchell asserts that the NPR suggests small firms can alleviate compliance costs by replacing non-compliant water beads with smaller ones that fulfill the size requirement. However, the commenter states that the NPR also says that the growth requirement will likely require the redesign of all water beads, as no known water bead products comply with the rule. Therefore, the commenter questions how firms can alleviate costs in the manner advocated above. Finally, the commenter asserts firms could replace non-compliant water beads with ones that conform to the size regulations, these smaller water beads are still non-compliant with the proposed regulation because they do not meet the limits on water bead growth.

Response: Staff are aware of water bead toys that meet the rule's size limit requirement, which is being able to pass through a 5.0 mm diameter gauge. Additionally, staff note the proposed 50 percent growth limit has been removed from the rule. However, nearly all products staff reviewed exceed the updated size limit requirement. Staff expect manufacturers will incur retooling costs to ensure compliance and this could be a significant one-time cost, incurred by the manufacturer. Manufacturers also have the option of re-marketing their non-compliant water beads for non-toy uses such as decorative purposes (*e.g.*, placement in candle holders), in vases or gardens for plant hydration, as air freshener products or deodorizers for cat litter, and for use in first-aid cold packs.

Comment: Connor Mitchell asks on what basis does CPSC believe that firms can sell non-compliant water beads in alternative non-toy markets. It fails to cite any market analysis or knowledge that would convince me that manufacturers or sellers could sell their non-compliant product into the non-toy water bead market. The commenter asks if the demand is already met in

the non-toy water bead market, what is there to show that the non-compliant water beads would fulfill additional demand.

Response: As stated in the preamble of the NPR (89 FR 73027) there are several examples of non-toy water bead products. For example, products outside of the scope of this rule include water beads used for various non-toy uses, such as water beads used for decorative purposes (e.g., placement in candle holders), in vases or gardens for plant hydration, as air freshener products or deodorizers for cat litter, and in first-aid cold packs. Also, additional demand is not required to sell products in already existing markets. Manufacturers would only make the transition if it was profitable to do so and as such would be creating an additional supply of the product. Generally, an increase in the supply of a product, given a stable product demand, results in a more competitive market.

Comment: The Toy Association asserts that staff estimate that “water beads over the size limit are less than 5 percent of the market based on the range of sizes from the descriptions and an assumed distribution” appears to be incorrect, since a significant portion of the hydrated water beads are larger than the proposed 9.0 mm diameter. A cursory review of water bead products on e-commerce sites illustrates water beads that are stated to expand to a size larger than the proposed 9.0 mm diameter threshold.

Response: Many of the water bead products available on the market that the commenter likely found in their cursory review are sold on e-commerce sites that are out of scope of this rule. Water bead toys are water beads designed, manufactured or marketed as a plaything for children under 14 years of age (consistent with the definition of a “toy” in ASTM F963). However, the commenter is correct that water beads over the size limit of 5.0 mm diameter (including the 9.0 mm diameter proposed in the NPR) likely do constitute more than 5 percent of the water bead toy market. Only some water bead toys are produced at sizes under the water bead diameter limit. Water bead toys that do not meet the proposed size limit would require modification.

I. Effective Date

Comment: Corey Lee and the Toy Association recommend the Commission extend the proposal's effective date from 90 days to 360 days. Kirksey Croft agrees the compressed time frame of 90 days will not give small businesses enough time to implement all the requirements set forth and asserts that many small businesses will be effectively shut out of the market due to compliance costs. Also, the packaging and labeling costs associated with transitioning products to other markets will inhibit many transitions. Additionally, China WTO/TBT National Notification & Enquiry Center states the new proposal will have a significant impact on small and medium-sized enterprises, due to product size design adjustments, substitution and optimization of acrylamide raw materials in product components, production and labeling of warning labels, and testing by third party organizations, etc. China recommends that the Commission should give a transitional period of 1-2 years.

Response: Although the rule includes mechanical, acrylamide, and labeling requirements, most of the test methods and test equipment are not unique, and the current ASTM F963 Toy Safety Standard utilizes several similar methods and equipment. Additionally, staff are aware of water beads currently on the market that comply with the rule's size limit and would pass through the 5.0 mm diameter gauge cited in the rule when fully expanded.

Companies that choose not to redesign and reduce the fully expanded size of their water beads to comply with this rule regulating water bead toys have the option to repurpose and remarket those products as non-toy water bead products. Therefore, the Commission is finalizing the 90-day effective date as proposed.

Comment: AAP urges CPSC to adopt the soonest possible feasible implementation date. AAP also advises CPSC to take measures in this rule to avoid a massive sell-off inventory that does not comply with the rule.

Response: The Administrative Procedure Act (APA) generally requires that the effective date of a rule be at least 30 days after publication of the final rule. 5 U.S.C. 553(d). The Commission proposed a 90-day effective date in the NPR, which is being finalized as proposed.

Comment: AAP advises CPSC to take measures in this rule to avoid a massive sell-off inventory that does not comply with the rule.

Response: CPSC expects manufacturers to do what is most economically feasible and beneficial for them. That may include repackaging or repurposing their non-compliant water beads to be sold for non-toy uses such as decorative purposes (e.g., placement in candle holders), in vases or gardens for plant hydration, as air freshener products or deodorizers for cat litter, and used in first-aid cold packs. Suppliers of non-compliant water beads may bypass traditional retail channels like wholesalers and retailers and use e-commerce platforms to sell-off inventory directly to consumers. Such sales would be subject to compliance and enforcement action when the rule becomes effective.

Comment: Kirksey Croft opines that the proposal raises severe concerns about laboratory readiness and compliance capabilities under the 90-day timeline. While 81 third party laboratories are CPSC-accepted under ASTM F963-23 and 153 under ASTM F963-17, none are accredited for the new testing protocols or equipped with specialized analytical equipment like LC-MS/MS. The accreditation process alone typically takes several months, due to new test protocols, personnel training, and formal acceptance.

Response: Although this rule introduces new acrylamide testing requirements that will require specialized analytical equipment, such as an LC-MS/MS system to measure acrylamide extractions, this equipment is commercially available and not unique. New equipment, such as LS-MS/MS systems, are regularly purchased by third party laboratories as new standards are introduced and other standards are updated. Similarly, third party laboratories develop test protocols and train personnel as needed, as new standards are introduced and standards are updated on a regular basis. While third party laboratories may not currently be CPSC-accepted

for the water bead rule, CPSC expects these laboratories will be competent to conduct the required testing and will have their International Organization for Standardization (ISO) accreditation and CPSC-acceptance updated in the normal course of accreditation. Finally, 90 days is the statutory time allotted to issue a notice of requirements (NOR) under section 14 of the CPSA.

VI. Description of the Final Rule for Water Bead Toys

Based on incident data described in section III of this preamble and the reasons provided in the NPR and staff's engineering, health sciences, and human factors assessments, the rule creates a new section 1250.4, Requirements for Water Beads for 16 CFR part 1250, Safety Standard Mandating ASTM F963 for Toys, adding performance and labeling requirements for water beads to better address the known water bead hazards and to provide the highest level of safety feasible for such products. Further, this rule revises the title of part 1250 from "Safety Standard Mandating ASTM F963 for Toys" to "Safety Standard for Toys," to reflect the inclusion of the requirements in this rule that do not incorporate by reference existing requirements in the ASTM F963 voluntary standard.

A. Section 1250.4(a) Scope and Purpose

This section establishes performance and labeling requirements for water bead toys and toys containing water beads to minimize the risk of children ingesting, inserting, aspirating, and choking on water beads. The provisions of this part are intended to eliminate or adequately reduce the risk of injury and death to children from water bead toy hazards. This section adds requirements for water bead toys in addition to the requirements of § 1250.2. Section 1250.4(a) is being finalized as proposed in the NPR.

B. Section 1250.4(b) Definitions

Section 1250.4(b) provides definitions for the following terms used in the rule: aspiration hazard, choking hazard, ingestion hazard, insertion hazard, and water bead. The definitions in § 1250.4(b) are being finalized as proposed in the NPR except for one change discussed below.

The language in the definition of water bead in the final rule has been amended from the proposed “water absorbent polymer” to “liquid absorbent polymer.” The change from “water” to the term “liquid” in the definition of water bead is to ensure the definition is broad enough to include water beads that can absorb liquids other than water that could present the same hazard.

C. Section 1250.4(c) Performance Requirements

Section 1250.4(c) provides performance requirements for water bead toys with mechanical requirements (§ 1250.4(c)(1)) and the accompanying test method, and acrylamide limit requirements (§ 1250.4(c)(2)) with the accompanying test. Section 1250.4(c) is being finalized as proposed in the NPR except as discussed below.

In section 1250.4(c)(1) of the final rule, the proposed funnel test gauge diameter has been reduced from 9.0 mm to 5.0 mm. See section V.B of the preamble for further details. The corresponding test methods have been revised by deleting sections 1250.4(c)(1)(iii) and (vi) from the test method as being unnecessary because the 50 percent expansion limit has been removed from the final rule, which makes it unnecessary to measure the water bead toy’s dehydrated dimensions (1250.4(c)(1)(iii)) and the percentage of expansion (1250.4(c)(1)(vi)) with calipers. The remaining paragraphs in the test method have been renumbered to reflect these changes. Finally, an additional test option allowing for a sieve test gauge to be used for testing multiple water beads has been added to the testing requirements in section 1250.4(c)(1), which is depicted below as the new Figure 3 as it appears in the codified text of the final rule.

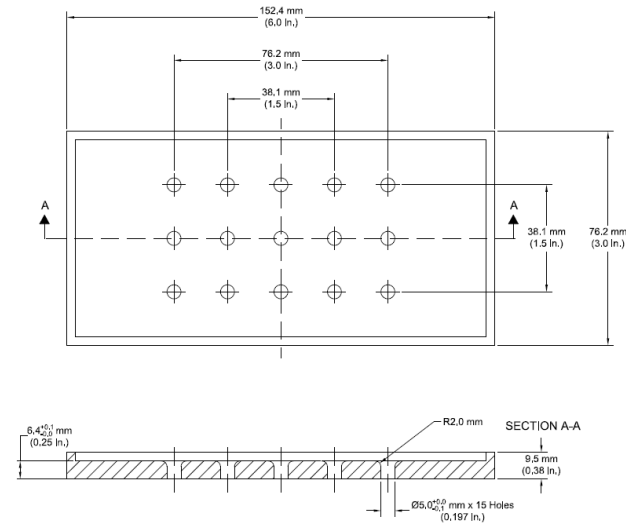

Figure 3 to paragraph (c)(1) – Sieve Test Gauge. Material: Polytetrafluorethylene (PTFE).

In section 1250.4(c)(2), the extractable acrylamide limit has been changed from 65 μg to 325 μg per 100 small beads or per 1 large bead in the final rule. Additionally, in section 1250.4(c)(2), for acrylamide testing, the proposed language of the definition for small and large water beads has been changed from the proposed “across the smallest diameter” for small water beads to “in all dimensions,” and for large water beads from “across the smallest diameter” to “in any dimension” in the final rule.

D. Section 1250.4(d) Labeling Requirements

Section 1250.4(d) provides the marking, labeling, and instructional literature requirements for water bead toys (marking and labeling in § 1250.4(d)(1)) and (instructional literature in § 1250.4(d)(2)). Section 1250.4(d) is being finalized as proposed in the NPR except as discussed below.

Several changes have been made to proposed Figures 3 and 4 in § 1250.4(d) as described below. In section 1250.4(d), Figures 3 (“Warning for Water Bead Toys and Packaging”) and 4 (“Toys That Contain Water Beads”) of the proposed rule have been renumbered in the final rule as Figures 4 and 5, respectively, and the figure captions have been revised for clarity. The Figure 4 caption now reads as, “Warning for Water Bead Toys and their Packaging,” and the Figure 5 caption now reads as, “Warning for Toys with Contained Water Beads and their Packaging.” In addition, both figures have been revised in the final rule to reflect changes in

warning content made in response to public comments and other clarifications. All changes described below apply to both figures, unless otherwise specified.

- The first sentence of the warning has been changed from “This product contains water beads that grow larger,” to “Contains water beads that can grow larger when swallowed or inserted in the ear or nose” in the final rule. This revision clarifies that the expansion of water beads can occur within the body after ingestion or insertion and brings greater attention to the common insertion hazard.
- The sentence, “Discard if beads are coming out,” in proposed Figure 4 has been changed to, “Discard product if beads start to come out,” to clarify that the product containing the water beads, not just the beads, should be discarded and that the product should be discarded as soon as any beads start to come out, rather than the beads having to be flowing out of the product. In addition, this sentence has been moved into the bullet list of precautionary statements in renumbered Figure 5 in the final rule, where hazard-avoidance statements are more appropriately located.
- The sentence, “Children have DIED after swallowing water beads because the beads blocked their intestines,” has been changed in the final rule to “Children have DIED when the beads blocked their intestines,” for brevity and to limit redundancy with the initial sentence of the warnings, which was revised to explicitly refer to swallowing.
- The sentence, “Your child can die too,” has been deleted in the final rule as unnecessary and unwarranted given the explicit reference to death in the prior sentence, which already emphasizes the urgency of the hazard and is likely to motivate consumers to act, and the relative rarity of fatalities.
- The sentence, “Inserted beads have resulted in surgeries,” has been added to the warnings in the final rule to identify the potentially consequences of exposure to the insertion hazard.

- The sentence, “Watch older children during use,” has been added to the warning in the final rule after the statement about keeping water beads away from babies and toddlers to emphasize the importance of monitoring older children’s use of water beads.
- The sentence, “Never use as a sensory toy or bath toy,” has been deleted from the final rule to prevent confusion about what constitutes a sensory toy. In addition, this language was intended to address young children, who commonly use water beads as sensory or bath toys. The warnings in the rule already explicitly warn to keep beads away from babies and toddlers.
- The sentence, “Seek immediate medical attention if you think your child swallowed beads or inserted beads into their nose, ears, or other part of the body,” has been changed in the final rule to, “Get medical help right away if you think your child swallowed or inserted beads,” to be more concise, to eliminate redundant information, and to be presented in more plain language, which is likely to increase the number of consumers able to read and understand the statement. The phrase, “Get medical help

right away,” also has been highlighted using boldface type in the final rule.

The renumbered Figures 4 and 5 as revised in the final rule are depicted below.

⚠️ WARNING
Contains water beads that can grow larger when swallowed or inserted in the ear or nose. Children have DIED when the beads blocked their intestines. Inserted beads have resulted in surgeries.
<ul style="list-style-type: none">• Keep away from babies and toddlers. Watch older children during use.• Get medical help right away if you think your child swallowed or inserted beads.

Figure 4 to Paragraph (d)(1)(i)—Warning for Water Bead Toys and their Packaging.

⚠️ WARNING
Contains water beads that can grow larger when swallowed or inserted in the ear or nose. Children have DIED when the beads blocked their intestines. Inserted beads have resulted in surgeries.
<ul style="list-style-type: none">• Keep away from babies and toddlers. Watch older children during use.• Discard product if beads start to come out.• Get medical help right away if you think your child swallowed or inserted beads.

Figure 5 to Paragraph (d)(1)(ii)—Warning for Toys with Contained Water Beads and their Packaging.

Section 1250.4(d)(1)(vi)(C) of the rule also corrects two minor typographical errors in the proposed rule. First, in the proposed rule, this section mistakenly referenced “section X of” ANSI Z535.4–2023; however, the Z535.4 standard does not have a section X. Thus, the phrase “section X of” has been deleted in the final rule. Second, in the proposed rule, this section mistakenly omitted the quotation marks at the beginning of the phrase, “safety white,” in the example that was provided. These missing quotation marks have been added for the final rule.

E. Section 1250.10 Incorporation by reference

Section 1250.10 creates a centralized incorporation by reference provision for part 1250 and incorporates by reference ANSI Z535.4–2023, *American National Standard for Product*

Safety Signs and Labels (approved December 14, 2023) and provides information on where that standard is available. ANSI Z535.4–2023 includes requirements related to safety alert symbol use; signal word selection; warning panel format, arrangement, and shape; color requirements for each panel; letter style; to identify and warn against specific hazards; and to provide information to avoid personal injury.

VII. Amendment to 16 CFR Part 1112 to Include Notice of Requirements for Safety Standard for Toys: Requirements for Water Beads

Products subject to a consumer product safety rule under the CPSA, or to a similar rule, ban, standard, or regulation under any other act enforced by the Commission, must be certified as complying with all applicable CPSC-enforced requirements. 15 U.S.C. 2063(a). Certification of children's products subject to a children's product safety rule must be based on testing conducted by a CPSC-accepted third party conformity assessment body. 15 U.S.C. 2063(a)(2). The Commission must publish an NOR for the accreditation of testing laboratories as third party conformity assessment bodies to assess conformity with a children's product safety rule. 15 U.S.C. 2063(a)(3). This rule for water bead toys is a children's product safety rule that requires the issuance of an NOR.

The Commission's rules, at 16 CFR part 1112, establish requirements for accreditation of third party conformity assessment bodies to test for conformance with a children's product safety rule in accordance with section 14(a)(2) of the CPSA. Part 1112 also lists the NORs that the CPSC has published. In the NPR, the Commission proposed to amend part 1112 to include the Safety Standard for Toys: Requirements for Water Beads in the list of children's product safety rules for which the CPSC has issued NORs. The numbering for proposed section 16 CFR 1112.15(b)(32)(ii)(LL) has been revised in the final rule to 16 CFR 1112.15(b)(32)(iv) for accuracy but is otherwise being finalized as proposed in the NPR.

Laboratories applying for acceptance as a CPSC-accepted third party conformity assessment body to test to the new Safety Standard for Toys: Requirements for Water Beads are

required to meet the third party conformity assessment body accreditation requirements in part 1112. When a laboratory meets the requirements as a CPSC-accepted third party conformity assessment body, the laboratory can apply to the CPSC to have the Safety Standard for Toys: Requirements for Water Beads included in its scope of accreditation as reflected on the CPSC Web site at: www.cpsc.gov/labsearch.

VIII. Feasibility of Requirements

Pursuant to section 106(c) of the CPSIA, Congress directed the Commission to “periodically review and revise the rules set forth under this section to ensure that such rules provide the highest level of safety for such products that is feasible.” 15 U.S.C. 2056b(c). The Commission’s statutory obligation is to ensure that toys have the highest level of safety that the producers are capable of achieving, considering technological and economic ability. Based on the staff’s analysis provided in the NPR and the responses to comments in the final rule, the Commission determines that the rule is technically and economically feasible.

A. Technological Feasibility

A rule is technically feasible if it is capable of being done. For example, compliant products might already be on the market; or the technology to comply with requirements might be commercially available; or existing products could be made compliant; or alternative practices, best practices, or operational changes would allow manufacturers to comply. *See, e.g.*, 15 U.S.C. 1278a(d) (discussing lead limits). The requirements of the final rule meet the technical feasibility criteria. For instance, some products currently available on the market are within the final rule’s 5.0 mm size limitation. There are also some products currently available on the market that meet the acrylamide limits of 325 µg of extractable acrylamide per 100 small beads or per one large bead. With respect to demonstrating compliance, the test gauge test does not require tools, like a push rod, to determine whether a water bead can pass through the gauge. Further, several testing tools required in the rule (*e.g.*, a small parts cylinder) are already included in CPSC mandatory standards or come from the ASTM F963 standard. Accordingly,

much of the technology is already used when testing to section 4.40 of ASTM F963–23 and is commercially available.

B. Economic Feasibility

The rule is economically feasible because non-compliant toy products can be redesigned to be compliant or can be repurposed and remarketed for non-toy uses. Based on staff’s analysis, the Commission expects manufacturers would incur material costs to redesign their product and retool their manufacturing processes to produce a compliant product to comply with the rule. Staff expect the redesign and retooling costs likely will be significant for small firms involved in the water bead toy market. Labeling costs are typically negligible, however a public comment stated that the labeling costs for these packages may be more complicated and require a new graphics plate which could cost up to \$1,000. These costs would be a one-time purchase spread over the production of likely thousands of units. Additionally, other options, such as hang tags, are available to manufacturers. A decline in sales is expected, as many currently available water bead toys would not be compliant with the rule. However, while the impact of the rule may be significant to suppliers, firms could sell compliant water bead toys or repurpose and remarket non-compliant water bead toys for non-toy purposes, such as agricultural purposes, decorative purposes, as air freshener products or deodorizers for cat litter, and in first-aid cold packs.

IX. Incorporation by Reference

The rule incorporates by reference ANSI Z535.4–2023, *American National Standard for Product Safety Signs*. In accordance with the regulations of the Office of the Federal Register, 1 CFR part 51, Part VI.E of this preamble summarizes the requirements of the ANSI Z535.4–2023. The standard is reasonably available to interested parties in several ways. Interested persons may purchase a copy of ANSI Z535.4–2023 from ANSI via its website, www.ansi.org, or by mail from ANSI, 25 West 43rd Street, 4th Floor, New York, NY 10036, telephone: (212)-642-4900. Once the rule takes effect, a read-only copy of ANSI Z535.4–2023 will be available for viewing, at no cost, on the ANSI website at: <https://ibr.ansi.org/Standards/nema.aspx>.

Alternatively, interested parties may inspect a copy of the standards at CPSC's Office of the Secretary by contacting Alberta E. Mills, Commission Secretary, U.S. Consumer Product Safety Commission, 4330 East West Highway, Bethesda, MD 20814; phone: (301) 504-7479; email: cpsc-os@cpsc.gov.

ASTM F963-23 is referenced in the amendatory text of this document and was previously approved for 16 CFR § 1250.2.

X. Effective Date

The Administrative Procedure Act (APA) generally requires that the effective date of a rule be at least 30 days after publication of the final rule. 5 U.S.C. 553(d). The Commission proposed a 90-day effective date in the NPR. For the reasons discussed in the response to comments in section V.H of this preamble, the Commission is finalizing the 90-day effective date as proposed in the NPR. Additionally, a 90-day effective date allows the rule going into effect to coincide with the third party testing requirements for children's products under section 14(a)(3) of the CPSA, as an NOR date must be no later than 90 days before such rules or revisions take place. 15 U.S.C. 2063(a)(3). The rule applies to all water beads toys manufactured after the effective date. 15 U.S.C. 2058(g)(1).

XI. Regulatory Flexibility Act

When an agency is required to publish a notice of proposed rulemaking, the Regulatory Flexibility Act (RFA, 5 U.S.C. 601-612) generally requires that the agency prepare an IRFA for the NPR and a final regulatory flexibility analysis (FRFA) for the final rule. 5 U.S.C. 603, 604. These analyses must describe the impact that the rule would have on small businesses and other entities. The FRFA must contain:

- (1) a statement of the need for and objectives of the rule;
- (2) significant issues raised by commenters on the IRFA, the agency's assessment of those issues, and changes made to the result as a result of the comments;

(3) a response to any comments filed by the Chief Counsel for Advocacy of the U.S. Small Business Administration (Advocacy), and changes made as a result of those comments;

(4) a description and estimate of the number of small entities to which the rule will apply;

(5) a description of the projected reporting, recordkeeping, and other compliance requirements of the rule, including an estimate of the classes of small entities which will be subject to the requirement and the type of professional skills necessary for preparation of the report or record; and

(6) steps the agency has taken to minimize the significant economic impact on small entities, consistent with the objective of the applicable statute, including the factual, policy, and legal reasons for selecting the alternative in the final rule and why other alternatives were rejected.

Staff prepared an IRFA for this rulemaking that was provided in the preamble of the NPR. The FRFA is provided below.

A. Need for and Objectives of the Rule

Section I of this preamble explains why the Commission is establishing a mandatory rule for water bead toys and provides a statement of the objectives of, and legal basis for the rule. Section II of this preamble describes the types of products within the scope of the rule, the market for water beads, and the use of water beads in the U.S. The requirements in the rule are more stringent than ASTM F963–23, which the Commission is incorporating into the mandatory rule 16 CFR part 1250, Safety Standard Mandating ASTM F963 for Toys, as described in sections IV and V of this preamble. The rule addresses the known hazards presented by water bead toys, discussed in section III of this preamble, that the current ASTM F963-23 does not adequately address.

B. Comments and Responses Concerning Impact on Small Entities

One hundred thirty-five comments were submitted in response to the NPR. However, none of the comments specifically addressed, or resulted in significant changes to, the initial regulatory flexibility analysis. A summary of the significant issues with possible economic impacts, clarifications and corrections to the initial analysis, and a summary of staff's assessment of such issues are contained in section V.F of this preamble.

C. Issues Raised by the Small Business Administration

The Small Business Administration (SBA) did not submit a comment on the proposed rule.

D. Small Entities to Which the Rule Would Apply

Section II of this preamble describes the products within the scope of the rule and an overview of the market for water beads. This section provides additional details on the market for products within the scope of the rule.

Staff has found that a majority of the firms that sell water bead toys are wholesalers of hobby goods, toys, and plastic products.⁵⁴ Retailers of water bead toy products are hobby and toy stores, department stores, and warehouse stores and supercenters.⁵⁵ Some of these products may be sold by convenience stores, but staff estimates the number of units sold from such stores is negligible. Water bead toys are small, novelty products which can easily be stored and sold on varying retail channels and therefore, the described retailers, importers, and manufacturers are not all inclusive but represent the most prominent sources for water bead toys.

Currently, over 30 firms supply water bead toys to the U.S. market. Most of the U.S.-based manufacturers and importers are small companies based on Small Business Administration

⁵⁴ The North American Industry Classification System (NAICS) defines product codes for U.S. firms. Firms advertise water bead products as toys, and therefore water beads may be categorized under many NAICS product codes. These firms could be listed in NAICS code 339930 Doll, Toy, and Game Manufacturing but some may also be listed in code 326199 All Other Plastic Product Manufacturing. Importers of these products could also vary among different NAICS codes. A majority of the firms should be listed in the following NAICS codes as wholesalers; 423920 Toy and Hobby Goods and Supplies Merchant Wholesalers, and 424610 Plastics Materials and Basic Forms and Shapes Merchant Wholesalers.

⁵⁵ Retailers consist of NAICS codes 459120 Hobby, Toy, and Game Stores, 455110 Department Stores, and 455211 Warehouse Clubs and Supercenters.

(SBA) size standards.⁵⁶ The SBA size standards for small entities are based on the number of employees or the annual revenue of the firm, and there is a specific size standard for each 6-digit North American Industry Classification Series (NAICS) category.⁵⁷ The U.S. Census Bureau conducts an annual survey of small businesses in the U.S. and tallies how many large and small businesses are in each NAICS category.⁵⁸ There is no NAICS category specifically for water bead manufacturing or importing. Firms that manufacture water bead toy products may be categorized as doll, toy, and game manufacturing or under the category “All Other Plastic Product Manufacturing.” Importers are generally considered a type of merchant wholesaler. As seen in Tables 1 and 2 below depicting applicable NAICS categories, the SBA small entity threshold for manufacturers is generally 150 to 750 employees.

Table 1 - Estimate of Number of Small Manufacturers and Importers

NAICS Code	Description	SBA Size Standard for Firms (# of Employees)	Number of Firms that meet size standard (Based on SUSB data)
339930	Doll, Toy, and Game Manufacturing	700	7
326199	All Other Plastic Product Manufacturing	750	1
424610	Plastics Materials and Basic Forms and Shapes Merchant Wholesalers	150	4
423920	Toy and Hobby Goods and Supplies Merchant Wholesalers	175	19

Table 2 - Estimate of Number of Small Retailers

NAICS Code ⁵⁹	Description	SBA Size Standard for Firms (Annual Revenue) Millions \$	Number of Firms that meet size standard (Based on SUSB data)
452210	Department Stores	\$40.0	15
452310	General Merchandise Stores, Including Warehouse Clubs and Supercenters	\$47.0	8,006

⁵⁶ Under SBA standards, a manufacturer, importer, and retailer of a product is categorized as a small entity based on their associated NAICS code. SBA uses the number of employees to determine if a manufacturer or importer is a small entity while SBA uses the amount of annual revenues for retailers.

⁵⁷ The North American Industry Classification System (NAICS) is the standard used by Federal statistical agencies in classifying business establishments for the purpose of collecting, analyzing, and publishing statistical data related to the U.S. business economy. For more information, see <https://www.census.gov/naics/>. Some programs use 6-digit NAICS codes, which provide more specific information than programs that use more general 3- or 4-digit NAICS codes.

⁵⁸ <https://www.census.gov/programs-surveys/susb/data/tables.html>.

⁵⁹ Note that there are discrepancies between the published SBA size standard NAICS code and the SUSB come. Staff used the code description to match the size standard to the correct value. Retailer size determinations were made using 2017 SUSB data and applying a ratio of the number of firms that meet the standard to the 2021 data values.

451120	Hobby, Toy, and Game Stores	\$35.0	4,660
--------	-----------------------------	--------	-------

Based on the Census Bureau's 2021 Statistics of U.S. Businesses (SUSB) data and a review of publicly available data on annual revenues, staff estimates the number of firms classified as small for the aforementioned NAICS codes to be eight manufacturers, 23 importers, and 12,681 retailers. These firms could be considered small and supply water bead toys.

E. Compliance, Reporting, Paperwork, and Recordkeeping Requirements of the Rule

The rule requires suppliers (manufacturers and importers) of water bead toys to meet performance, warning label, and user instruction requirements, and to conduct third party testing to demonstrate compliance. This section discusses the reporting and paperwork requirements. As required by the Paperwork Reduction Act of 1995, CPSC receives approval of information collection requirements pertaining to third party for children's products under OMB Control Number 3041-0159.

Manufacturers must demonstrate that they have met the performance requirements of the rule by providing a children's product certificate. As specified in 16 CFR part 1109, suppliers who are not the original manufacturer, such as importers, may rely on the testing or certification suppliers provide, as long as the requirements in part 1109 are met. Manufacturers and importers are required to furnish certificates to retailers and distributors (section 14(g)(3) of the CPSA); retailers are not required to third party test the children's products that they sell unless they are also the manufacturer or importer. Under section 14 of the CPSA, manufacturers, importers, and private labelers of water bead toys will be required to certify, based on a test of each product conducted by third party conformity assessment body, that their products comply with the requirements of the rule. Each children's product certificate must identify the third party conformity assessment body that conducted the testing upon which the certificate is based.

F. Impact of the Rule on Small Entities

Water bead toys that expand and are unable to pass through a 5.0 mm diameter gauge when tested pursuant to section 8.30, *Expanding Materials Test Method* of ASTM F963-23, with

modifications in the rule, would require modification to meet the rule or be taken off the market. Additionally, water beads toys that do not meet the acrylamide limit would require modification or discontinuation.

The Commission assesses it is likely that a substantial number of small firms will incur significant costs from redesign, retooling, loss of sales, or the purchase and installation of new components. Staff have identified some water bead toys that are produced at sizes under the maximum water bead size limit of 5.0 mm. Staff estimates that water bead toys over the size limit are a significant portion of the market and that most available water bead toys currently available on the market would not be compliant.

Staff reviewed product descriptions for popular water bead toy retail packages and found that most are sold in mixed sizes with water bead toys that are typically over the maximum size limit of the rule. Staff estimates that water bead toys under the size limit are less than 5 percent of the market based on the range of sizes in these descriptions. Staff assess water bead toys over the established limit can be replaced with sizes smaller than the limit to comply with the rule, however these water bead toys may need to be redesigned by the manufacturer. Given this requirement, and the likelihood that most currently available water bead toys would not be compliant, staff expects some small firms to exit the market, or to no longer package and advertise their products as toys but instead as agricultural or decorative home products (although firms may be able to redesign toys with water beads that expand to less than 5.0 mm diameter). Due to the uncertainty related to redesigning these products, staff cannot generate an estimate of the potential costs of the rule.

Firms might incur a small one-time additional cost from updating existing labels and/or adding labels. Generally, the costs associated with modifying or adding warning labels are low on a per unit basis because all manufacturers of children's products are already required to provide labels with their product pursuant to section 14(a)(5) of the CPSA. In the NPR, staff estimated additional costs related to updating labels as less than \$0.01 per unit of product sold,

which is a typical industry assumption. However, a commenter stated that labelling and repackaging for water beads may be more complex and submitted a cost estimate for a graphic plate of up to \$1,000. Staff consider this to be the high-end of potential cost for labelling, and that the existence of less expensive alternatives, such as hang tags, will drive firms to less expensive options. Additionally, this one-time \$1,000 costs will be spread across thousands of units.

G. Impact on Small Manufacturers

Staff considers 1 percent of revenue to be a “significant” economic impact, consistent with other federal government agencies. Staff expect that small manufacturers would incur significant costs from redesign, retooling, loss of product sales, and material change to comply with the rule. Overall, staff assess that a substantial number of small manufacturing firms will likely incur a significant cost from the rule, although sale losses would be mitigated to the extent that manufacturers repurpose and remarket non-compliant water bead toys for non-toy uses (*e.g.*, agricultural or decorative).

H. Third Party Testing Costs

The final rule requires manufacturers and importers of water bead toys to comply with additional performance requirements and demonstrate compliance by required third party testing. As specified in 16 CFR part 1109, entities that are not manufacturers of children’s products, such as importers, may rely on the certificate of compliance provided by others.

Water bead toy manufacturers are already required to certify compliance of children’s products using CPSC-accepted third party testing. The certification must be based on a test of each product performed by a CPSC-accepted third party conformity assessment body. Based on quotes from testing laboratories for ASTM F963 mechanical services and chemistry testing services, the cost of certification testing ranges from \$300 to \$500 per product sample. However, manufacturers could incur additional costs for certifying compliance with the rule. Some laboratories currently not performing acrylamide testing in other contexts may incur

retooling costs to perform the necessary testing, which could result in higher prices per product sample. In addition, third party testing laboratories will likely need to invest in new testing equipment to test to the new requirements and would pass the costs of the additional testing equipment on to the supplier. CPSC expects an incremental cost increase of \$50 in the cost of testing water bead toys to the rule.⁶⁰

I. Other Federal Rules That May Duplicate, Overlap, or Conflict with the Final Rule

CPSC has not identified any other federal rules that duplicate, overlap, or conflict with the final rule.

J. Alternatives Considered to Reduce the Impact on Small Entities

The Commission considered three alternatives to the final rule that could reduce the impact on small entities: (1) not establishing a mandatory standard for water beads, (2) establishing an information and education campaign, or (3) setting a later effective date.

1. Not establishing a mandatory standard

Section 106 of the CPSIA requires CPSC to periodically review and revise ASTM F963 to ensure that such standards provide the highest level of safety for such products that is feasible. Given CPSC's statutory mandate, and continuing incidents associated with water bead toys as described in section III of this preamble, the Commission has determined that it must address the safety of children using water bead toys to ensure that the risks of ingestion and insertion into the body are mitigated. While failing to promulgate a mandatory standard for water beads would have no direct impact on U.S. small businesses, it would allow hazardous products to remain on the market and do nothing to reduce known hazards associated with water bead toys. This option might be selected if it were believed that the risk associated with these products is acceptable and that agency warning efforts have resulted, or will result, in the necessary market changes to

⁶⁰ Third party testing laboratories would need to invest approximately \$200 in performance testing equipment to test to the new requirements. Staff assumes each testing lab would test 4 product samples to the performance requirements and would pass the costs of the additional testing equipment on to the supplier. (\$200 in new equipment ÷ 4 tests of product samples = an additional \$50 per test.)

product can be tested to the rule. Smaller companies are less likely to have the resources to quickly come into compliance with the rule than larger ones, and a minority of the small U.S. companies that have products in scope of this rule have multiple products that do not appear to meet the new performance requirements. However, the Commission finds that providing a longer effective date would allow the hazards of water bead toys to be unaddressed for a later period of time resulting in more deaths and injuries, and thus, would unreasonably delay addressing the ingestion hazard associated with water beads.

XII. Paperwork Reduction Act

This rule contains information collection requirements that are subject to public comment and review by the Office of Management and Budget (OMB) under the Paperwork Reduction Act of 1995 (PRA; 44 U.S.C. 3501–3521). The preamble to the NPR discussed the information collection burden of the rule and specifically requested comments on the accuracy of CPSC’s estimates. 89 FR 73045 (September 9, 2024). The NPR described the provisions of the rule and provided an estimate of the annual reporting burden for the rule under the PRA. The estimated burden of this collection of information is unchanged from the NPR. CPSC did not receive any comments regarding the information collection burden in the NPR through OMB. OMB has assigned control number 3041-0206 to this information collection.

XIII. Certification and Notice of Requirements

Section 14(a) of the CPSA imposes the requirement that products subject to a consumer product safety rule under the CPSA, or to a similar rule, ban, standard, or regulation under any other act enforced by the Commission, must be certified as complying with all applicable CPSC-enforced requirements. 15 U.S.C. 2063(a). Section 14(a)(2) of the CPSA requires that certification of children’s products subject to a children’s product safety rule be based on testing conducted by a CPSC-accepted third party conformity assessment body. Section 14(a)(3) of the CPSA requires the Commission to publish an NOR for the accreditation of third party conformity assessment bodies (or laboratories) to assess conformity with a children’s product

safety rule to which a children's product is subject. The rule creates a new 16 CFR § 1250.4 as part of 16 CFR part 1250 that is a children's product safety rule that requires the issuance of an NOR.

16 CFR part 1112 establishes requirements for accreditation of third party conformity assessment bodies to test for conformity with a children's product safety rule in accordance with section 14(a)(2) of the CPSA. Part 1112 also codifies all of the NORs issued previously by the Commission. To meet the requirement that the Commission issue an NOR for the rule, the rule adds water beads to the list of children's product safety rules for which CPSC has issued an NOR.

Testing laboratories applying for acceptance as a CPSC-accepted third party conformity assessment body to test to the new standard for water bead toys would be required to meet the third party conformity assessment body accreditation requirements in part 1112. When a laboratory meets the requirements as a CPSC-accepted third party conformity assessment body, the laboratory can apply to CPSC to have 16 CFR § 1250.4, Safety Standard for Toys: Requirements for Water Beads, included within the laboratory's scope of accreditation of CPSC safety rules listed for the laboratory on the CPSC website at: <https://www.cpsc.gov/cgi-bin/labsearch/>.

Testing laboratories should not be adversely impacted as a result of this rule. Approximately 155 third party testing laboratories are CPSC-accepted to test compliance with expanding materials as provided in section 4.40 of ASTM F963-23. Staff expect that these laboratories will become accredited and CPSC-accepted to test to this new rule in the normal course of business. CPSC expects that these laboratories will be able to test to this rule within a short time period. Furthermore, no laboratory is required to provide testing services. The only laboratories that are expected to provide such services are those that anticipate receiving sufficient revenue from the mandated testing to justify procuring the testing equipment and obtaining accreditation.

XIV. Preemption

Section 26(a) of the CPSA, 15 U.S.C. 2075(a), states that when a consumer product safety standard is in effect and applies to a product, no state or political subdivision of a state may either establish or continue in effect a standard or regulation that prescribes requirements for the performance, composition, contents, design, finish, construction, packaging, or labeling of such product dealing with the same risk of injury unless the state requirement is identical to the federal standard. Section 106(f) of the CPSIA deems rules issued under that provision “consumer product safety standards.” Therefore, once a rule issued under section 106 of the CPSIA takes effect, it will have preemptive effect in accordance with section 26(a) of the CPSA.

XV. Environmental Considerations

Certain categories of CPSC actions normally have “little or no potential for affecting the human environment” and therefore do not require an environmental assessment or an environmental impact statement. Safety standards providing requirements for consumer products come under this categorical exclusion. 16 CFR 1021.5(c)(1). The final rule for water bead toys falls within the categorical exclusion.

XVI. Congressional Review Act and Executive Order 12866

Pursuant to the Congressional Review Act (CRA) and Executive Order (EO) 12866, the Office of Management and Budget’s Office of Information and Regulatory Affairs has determined that this rule does not qualify as a “major rule,” as defined in 5 U.S.C. 804(2), and is not a significant regulatory action as defined under section 2(f) of EO 12866. To comply with the CRA, CPSC will submit the required information to each House of Congress and the Comptroller General.

List of Subjects

16 CFR Part 1112

Administrative practice and procedure, Audit, Consumer protection, Reporting and recordkeeping requirements, Third party conformity assessment body.

16 CFR Part 1250

Consumer protection, Incorporation by reference, Infants and children, Labeling, Law enforcement, Toys.

For the reasons discussed in the preamble, the Commission proposes to amend 16 CFR parts 1112 and 1250 as follows:

PART 1112—REQUIREMENTS PERTAINING TO THIRD PARTY CONFORMITY ASSESSMENT BODIES

1. The authority citation for part 1112 continues to read as follows:

Authority: 15 U.S.C. 2063.

2. Amend § 1112.15 by reserving paragraph (b)(32)(iii) and adding paragraph (b)(32)(iv) to read as follows:

§ 1112.15 When can a third party conformity assessment body apply for CPSC acceptance for a particular CPSC rule and/or test method?

* * * * *

(b) * * *

(32) * * *

(iii) [Reserved]

(iv) 16 CFR 1250.4, Requirements for Water Beads.

* * * * *

PART 1250—SAFETY STANDARD FOR TOYS

3. The authority citation for part 1250 continues to read as follows:

Authority: 15 U.S.C. 2056b.

4. Revise the heading of part 1250 to read as set forth above.

5. Revise § 1250.1 to read as follows:

§ 1250.1 Scope.

This part establishes a consumer product safety standard for toys.

6. Revise § 1250.2(a) to read as follows:

§ 1250.2 Requirements for toy safety.

(a) Each toy must comply with all applicable provisions of ASTM F963-23 (incorporated by reference, see § 1250.10).

* * * * *

7. Add § 1250.4 to read as follows:

§ 1250.4 Requirements for water beads.

(a) *Scope and purpose.* This section establishes performance and labeling requirements for water bead toys and toys containing water beads to minimize the risk of children ingesting, inserting, aspirating, and choking on water bead toys. The provisions of this part are intended to eliminate or adequately reduce the risk of injury and death to children from water bead toy hazards. This section adds requirements for water bead toys in addition to the requirements of § 1250.2.

(b) *Definitions.* In addition to the definitions in ASTM F963-23 (incorporated by reference, see § 1250.10), the following definitions apply for purposes of this section:

Aspiration hazard means a hazard caused by a child inhaling a water bead whereby the water bead can become lodged in the respiratory tract and can potentially cause death or injury.

Choking hazard means a hazard cause by a child attempting to swallow a water bead whereby the water bead can become lodged in the throat and can potentially cause death or injury.

Ingestion hazard means a hazard caused by a child swallowing a water bead whereby the water bead can become lodged in the digestive tract and can potentially cause death or injury.

Insertion hazard means a hazard caused by a child putting a water bead in the ear canal or nasal passage of the body and can potentially cause death or injury.

Water bead means a various shaped liquid absorbent polymer, composed of materials such as, but not limited to, polyacrylamide and polyacrylate, which expands when soaked in liquid.

(c) *Performance requirements.* In addition to the requirements of § 1250.2, all water bead toys and toys containing water beads within the scope of the rule must meet the performance requirements in this section to minimize the risk of children ingesting, inserting, aspirating, and choking on water beads.

(1) *Size limit requirements.* Water beads as received or water beads removed from a toy, which fit entirely inside the small parts cylinder in their dehydrated (pre-expanded) state as shown in figure 1 to this paragraph (c)(1) (16 CFR 1501.4) shall, after expansion, remain whole while completely passing through the funnel test gauge as shown in figure 2 to this paragraph (c)(1) or sieve test gauge as shown in figure 3 to this paragraph (c)(1), under its own weight, when tested in accordance with the following test procedure:

Figure 1 to paragraph (c)(1) – Small Parts Cylinder

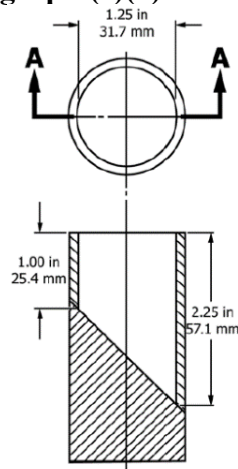

Figure 2 to paragraph (c)(1) – Funnel Test Gauge. Material: Polytetrafluorethylene (PTFE)

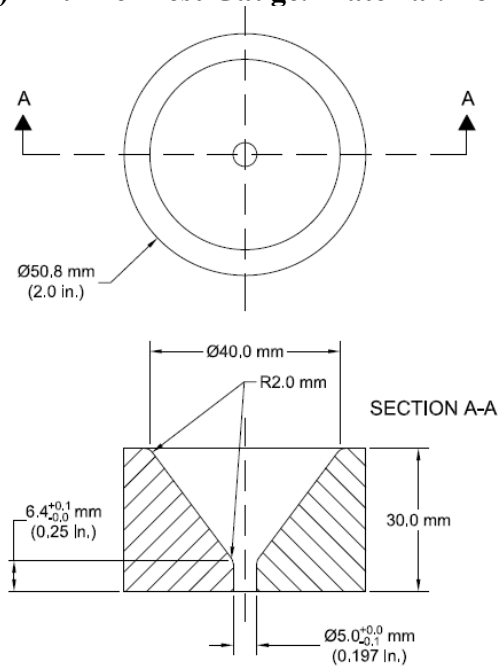
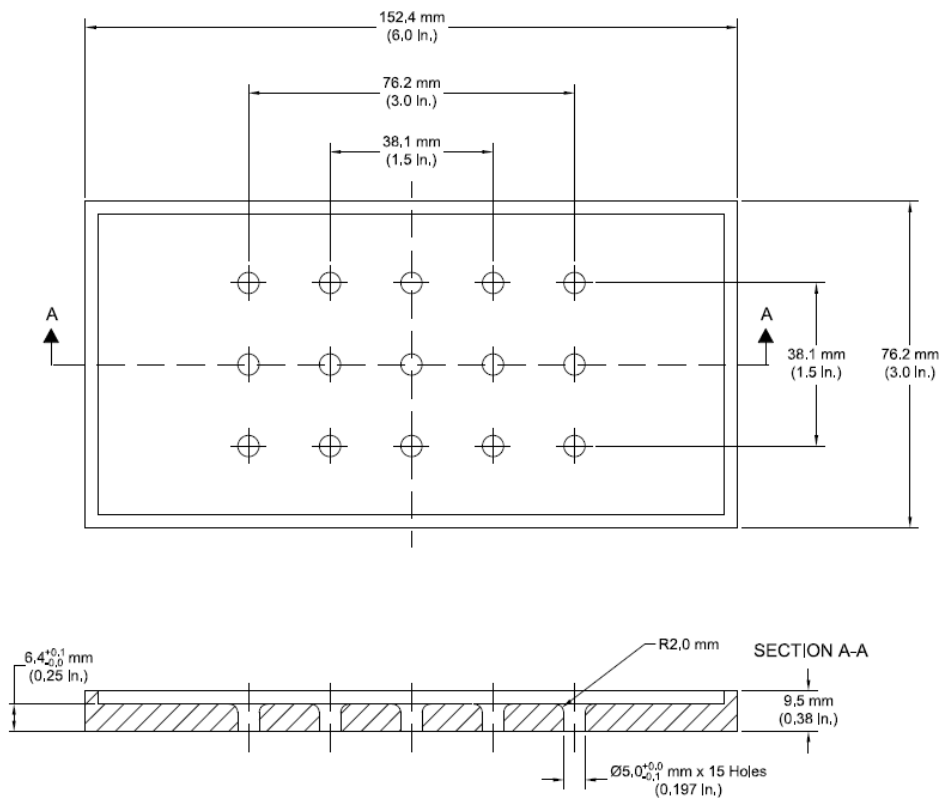

Figure 3 to paragraph (c)(1) – Sieve Test Gauge. Material: Polytetrafluorethylene (PTFE)



(i) Condition the water bead or toy containing the water bead, at $20 \pm 5 \text{ }^\circ\text{C}$ ($68 \pm 9 \text{ }^\circ\text{F}$)

and at a relative humidity of 40-65 percent for a minimum of seven hours prior to the test.

(ii) If the water bead is partially expanded, or contained within a toy and partially expanded, remove the water bead for testing and allow 120 hours to dehydrate before confirming the water bead fits entirely inside the small parts cylinder in its dehydrated state.

(iii) Submerge the water bead under a test bath of deionized water maintained at 37 ± 2 °C (98.6 ± 3.6 °F) for the duration of immersion, without agitation. For water beads that exhibit positive buoyancy, place weight(s) (with mass just sufficient to achieve complete submersion) atop the water bead. Care should be taken to minimize contact of the water bead with the sides or bottom of the container.

(iv) Maintain submersion for 72 hours, measuring the water bead dimensions at 6 hours, 24 hours, 48 hours and 72 hours duration. If the greatest expansion was observed at 72 hours of submersion, proceed to immediately test the expanded water bead. If the greatest expansion was observed at another time interval, condition and submerge a new water bead per paragraphs (c)(1)(i) through (iii) of this section for the time interval at which the greatest expansion was observed. Then immediately test the expanded water bead.

(v) Place the expanded water bead on the surface of the funnel or sieve gauge as applicable in the orientation least likely to pass through the funnel or sieve gauge opening and observe if the expanded water bead is able to completely pass through the funnel or sieve gauge opening. The expanded water bead shall remain whole and completely pass through the funnel or sieve gauge opening.

(2) *Acrylamide limit requirements.* Water beads shall not have more than 325 µg acrylamide extractable from 100 small water beads (defined as < 4 mm in all dimensions of the bead prior to hydration) or from one large water bead (defined as ≥ 4 mm in any dimension of the bead prior to hydration) in the test procedure described in paragraphs (c)(2)(i) through (vi):

(i) To determine the amount of extractable acrylamide in water beads, first place the water beads (one large water bead or 100 small water beads) as received in a container with deionized water that has been pH neutralized.

(ii) Situate the container(s) in a shaker bath that can heat the water beads to 37 °C and shake them at a rate of 30 revolutions per minute (RPM). Leave the water beads untouched for 24 hours.

(iii) Multiple concurrent trials, or sequential repetitions, must be performed to ensure that results are reasonably consistent, given any bead-to-bead variation. For large water beads, perform three trials with one large bead per trial. For small water beads, perform three trials with 100 small beads per trial. Each trial is conducted in a separate container of deionized water that has been pH neutralized.

(iv) Use an extraction container and volume of deionized water so that all water beads remain covered by water for the duration of the extraction period. Because water beads absorb water differently depending on their various sizes, additional tests may need to be conducted before starting the extractions to determine a volume of water that allows for full growth and coverage of the water beads without unnecessarily diluting the concentration of extracted acrylamide. Select containers that will not compress the water beads at any point during the 24-hour extraction period.

(v) Cover the containers to prevent evaporation of the water during the extraction.

(vi) Following the extraction, determine the volume of remaining water for each trial. Analyze the remaining water to determine the mass of extracted acrylamide present using an instrument that can quantitate acrylamide at levels equal to or less than the limit.

(d) *Labeling requirements.* All water bead toys and packaging of toys containing water beads within the scope of the rule must meet the marking, labeling, and instructional literature requirements in this section to minimize the risk of children ingesting, inserting, aspirating, and choking on water beads.

(1) *Requirements for marking and labeling.* (i) Water bead toys, packaging of water bead toys, and the container of water beads, if provided, must include the safety alert symbol, signal word, and word message as shown in figure 4 to this paragraph (d)(1)(i).

Figure 4 to paragraph (d)(1)(i)—Warning for Water Bead Toys and their Packaging.



(ii) Products with contained water beads, such as balls filled with water beads, and the packaging must include the safety alert symbol, signal word, and word message as shown in figure 5 to this paragraph (d)(1)(ii):

Figure 5 to paragraph (d)(1)(ii)—Warning for Toys with Contained Water Beads and their Packaging.

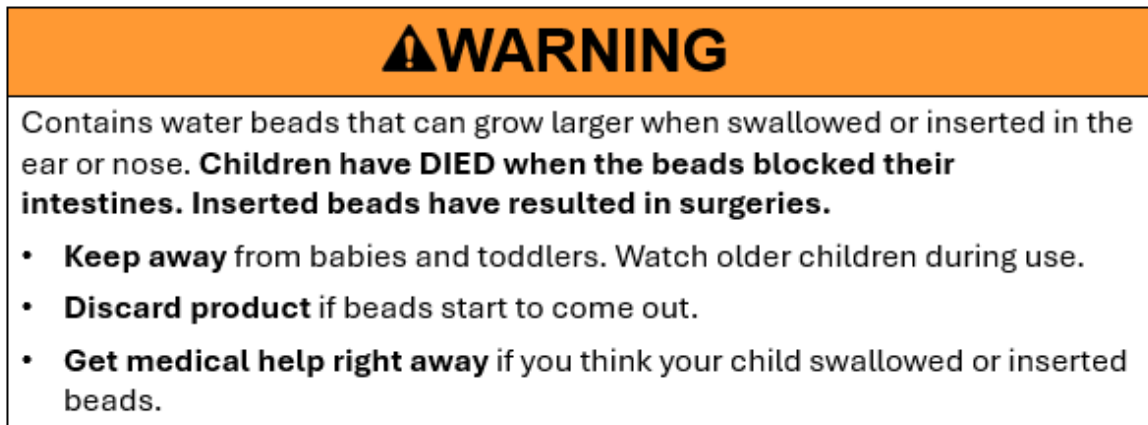

(iii) Products with contained water beads that do not have packaging must have a hangtag or sticker label with the full warning(s). Multiple products sold in a package or bin must be individually labeled with a hangtag or sticker.

(iv) The warnings shall be in the English language at a minimum.

(v) The warnings shall be conspicuous and permanent on the principal display panel as defined in section 3.1.62 of the version of ASTM F963-23 and in a distinct color contrasting to the background on which it appears.

(vi) The warnings shall conform to ANSI Z535.4–2023 (incorporated by reference, see § 1250.10), sections 6.1–6.4, 7.2–7.6.3, and 8.1, with the following changes:

(A) In sections 6.2.2, 7.3, 7.5, and 8.1.2, of ANSI Z535.4–2023 replace the word “should” with the word “shall.”

(B) In section 7.6.3 of ANSI Z535.4–2023, replace the phrase “should (when feasible)” with the word “shall.”

(C) In ANSI Z535.4–2023, strike the word “safety” when used immediately before a color (for example, replace “safety white” with “white”).

(vii) Certain text in the message panel must be in bold and in capital letters as shown in the example warning labels in figure 4 to paragraph (d)(1)(i) of this section and figure 5 to paragraph (d)(1)(ii) of this section. Text must use black lettering on a white background or white lettering on a black background.

(viii) The message panel text shall appear in sans serif letters and be center or left aligned. Text with precautionary (hazard avoidance) statements shall be preceded by bullet points.

(ix) Multiple precautionary statements shall be separated by bullet points if paragraph formatting is used.

(x) The safety alert symbol  and the signal word “WARNING” shall appear in sans serif letters and be at least 1/8” (3.2 mm) high and be center or left aligned. The remainder of the text shall be in characters whose upper case shall be at least 1/16” (1.6 mm) high.

(xi) The safety alert symbol, an exclamation mark in a triangle, when used with the signal word, must precede the signal word. The base of the safety alert symbol must be on the same horizontal line as the base of the letters of the signal word. The height of the safety alert symbol must equal or exceed the signal word letter height. The exclamation mark must be at least half the size of the triangle centered vertically.

(2) *Requirements for instructional literature.* Instructions shall have the same warning labels that must appear on the product packaging, with similar formatting requirements, but without the need to be in color. However, the signal word and safety alert symbol shall contrast with the background of the signal word panel, and the warnings shall contrast with the background of the instructional literature.

8. Add § 1250.10 to read as follows:

§ 1250.10 Incorporation by reference.

Certain material is incorporated by reference into this part with the approval of the Director of the Federal Register in accordance with 5 U.S.C. 552(a) and 1 CFR part 51. All approved incorporation by reference (IBR) material is available for inspection at the U.S. Consumer Product Safety Commission and at the National Archives and Records Administration (NARA). Contact the U.S. Consumer Product Safety Commission at: the Office of the Secretary, U.S. Consumer Product Safety Commission, 4330 East West Highway, Bethesda, MD 20814, telephone (301) 504-7479, email: cpsc-os@cpsc.gov. For information on the availability of this material at NARA, visit www.archives.gov/federal-register/cfr/ibr-locations or email fr.inspection@nara.gov. The material may be obtained from the following sources:

(a) ASTM International: 100 Barr Harbor Drive, PO Box C700, West Conshohocken, PA 19428-2959; telephone (610) 832-9585; www.astm.org.

(1) ASTM F963-23, Standard Consumer Safety Specification for Toy Safety, approved on August 1, 2023; into §§ 1250.2(a), 1250.4(b) and (d).

(2) [Reserved]

(b) National Electrical Manufacturers Association (NEMA): 1300 North 17th Street, Suite 900, Rosslyn, Virginia 22209; (703) 841-3200; www.nema.org.

(1) ANSI Z535.4–2023, American National Standard for Product Safety Signs and Labels (approved December 14, 2023); into § 1250.4(d).

(2) [Reserved]

Alberta E. Mills,
Secretary, Consumer Product Safety Commission.

