



DEPARTMENT OF TRANSPORTATION

Federal Aviation Administration

14 CFR Part 39

[Docket No. FAA-2025-0922; Project Identifier MCAI-2024-00650-R]

RIN 2120-AA64

Airworthiness Directives; Airbus Helicopters

AGENCY: Federal Aviation Administration (FAA), DOT.

ACTION: Notice of proposed rulemaking (NPRM).

SUMMARY: The FAA proposes to supersede Airworthiness Directive (AD) 2021-26-07, which applies to all Airbus Helicopters Model EC120B helicopters. AD 2021-26-07 requires performing repetitive inspections of the tail rotor (TR) hub body and, depending on the inspection results, replacing certain parts, and accomplishing further inspections. AD 2021-26-07 also requires for certain helicopters removing from service any bolt, washer, and nut installed on the TR hub body at certain life limits and replacing them with airworthy parts and accomplishing further inspections. Additionally, AD 2021-26-07 prohibits the installation of a certain part-numbered TR hub body unless certain requirements are met. Since the FAA issued AD 2021-26-07, it was determined that modifying the link of the TR hub body and splined flange by adding red paint marks is necessary to enable the detection of any loss of tightening torque. This proposed AD would require the same repetitive inspections and corrective actions as AD 2021-26-07 and would require modification of the link of the TR hub body, which would be a terminating action for the repetitive inspections. The proposed AD would also require repetitive inspections of the red paint line added during the modification of the link of the TR hub body for alignment. The FAA is proposing this AD to address the unsafe condition on these products.

DATES: The FAA must receive comments on this NPRM by [INSERT DATE 45 DAYS AFTER DATE OF PUBLICATION IN THE FEDERAL REGISTER].

ADDRESSES: You may send comments, using the procedures found in 14 CFR 11.43 and 11.45, by any of the following methods:

- Federal eRulemaking Portal: Go to [regulations.gov](https://www.regulations.gov). Follow the instructions for submitting comments.

- Fax: (202) 493-2251.

- Mail: U.S. Department of Transportation, Docket Operations, M-30, West Building Ground Floor, Room W12-140, 1200 New Jersey Avenue SE, Washington, DC 20590.

- Hand Delivery: Deliver to Mail address above between 9 a.m. and 5 p.m., Monday through Friday, except Federal holidays.

AD Docket: You may examine the AD docket at [regulations.gov](https://www.regulations.gov) under Docket No. FAA-2025-0922; or in person at Docket Operations between 9 a.m. and 5 p.m., Monday through Friday, except Federal holidays. The AD docket contains this NPRM, the mandatory continuing airworthiness information (MCAI) any comments received, and other information. The street address for Docket Operations is listed above.

Material Incorporated by Reference:

- For Airbus Helicopters material identified in this proposed AD, contact Airbus Helicopters, 2701 North Forum Drive, Grand Prairie, TX 75052; phone: (972) 641-0000 or: (800) 232-0323; fax: (972) 641-3775; website: airbus.com/en/products-services/helicopters/hcare-services/airbusworld.

- You may view this material at the FAA, Office of the Regional Counsel, Southwest Region, 10101 Hillwood Parkway, Room 6N-321, Fort Worth, TX 76177. For information on the availability of this material at the FAA, call (817) 222-5110. It is also available at [regulations.gov](https://www.regulations.gov) under Docket No. FAA-2025-0922.

FOR FURTHER INFORMATION CONTACT: Camille Seay, Aviation Safety Engineer, FAA, 1600 Stewart Avenue, Suite 410, Westbury, NY 11590; phone: (817)

222-5149; email: camille.l.seay@faa.gov.

SUPPLEMENTARY INFORMATION:

Comments Invited

The FAA invites you to send any written relevant data, views, or arguments about this proposal. Send your comments using a method listed under the ADDRESSES section. Include “Docket No. FAA-2025-0922; Project Identifier MCAI-2024-00650-R” at the beginning of your comments. The most helpful comments reference a specific portion of the proposal, explain the reason for any recommended change, and include supporting data. The FAA will consider all comments received by the closing date and may amend the proposal because of those comments.

Except for Confidential Business Information (CBI) as described in the following paragraph, and other information as described in 14 CFR 11.35, the FAA will post all comments received, without change, to regulations.gov, including any personal information you provide. The agency will also post a report summarizing each substantive verbal contact received about this NPRM.

Confidential Business Information

CBI is commercial or financial information that is both customarily and actually treated as private by its owner. Under the Freedom of Information Act (FOIA) (5 U.S.C. 552), CBI is exempt from public disclosure. If your comments responsive to this NPRM contain commercial or financial information that is customarily treated as private, that you actually treat as private, and that is relevant or responsive to this NPRM, it is important that you clearly designate the submitted comments as CBI. Please mark each page of your submission containing CBI as “PROPIN.” The FAA will treat such marked submissions as confidential under the FOIA, and they will not be placed in the public docket of this NPRM. Submissions containing CBI should be sent to Camille Seay, Aviation Safety Engineer, FAA, 1600 Stewart Avenue, Suite 410, Westbury, NY 11590. Any commentary that the FAA receives which is not specifically designated as CBI will be placed in the public docket for this rulemaking.

Background

The FAA issued AD 2021-26-07, Amendment 39-21866 (86 FR 72829, December 23, 2021) (AD 2021-26-07), for Airbus Helicopters Model EC120B helicopters. AD 2021-26-07 was prompted by European Union Aviation Safety Agency (EASA) AD 2021-0069, dated March 11, 2021 (EASA AD 2021-0069), issued by EASA, which is the Technical Agent for the Member States of the European Union, to address loss of tightening torque in the interface between the TR hub body and splined flange, which creates the risk of crack initiation from a fretting area located on the TR hub body and splined flange or on the TR hub body and flange bolts.

AD 2021-26-07 requires performing repetitive inspections of the TR hub body for a crack, and depending on the inspection results, removing the affected parts from service and inspecting the TR spline flange and, depending on those inspection results, removing an affected splined flange from service. AD 2021-26-07 also requires, for certain helicopters, removing from service any bolt, washer, and nut installed on the TR hub body that has exceeded a certain life limit, and thereafter removing these parts from service within specific intervals and accomplishing further inspections and corrective actions.

Additionally, AD 2021-26-07 prohibits installing a certain part-numbered TR hub body unless certain requirements are met. The FAA issued AD 2021-26-07 to detect cracking and fretting, which if not addressed, could result in potential loss of the TR drive and consequent loss of yaw control of the helicopter.

Actions Since AD 2021-26-07 was Issued

Since the FAA issued AD 2021-26-07, EASA superseded EASA AD 2021-0069 with EASA AD 2024-0209, dated October 28, 2024 (EASA AD 2024-0209) (also referred to as the MCAI), to address an unsafe condition on all Airbus Helicopters Model EC 120 B helicopters. The MCAI states that, Airbus Helicopters developed a modification, which consists of adding a line of red paint on each bolt and each nut of the link between the TR hub and the splined flange. The MCAI further states that an Airworthiness Limitations Section task was published for checking alignment of the marks.

The FAA is proposing this AD to detect cracking and fretting of the TR hub body, which, if not addressed, could lead to loss of the TR drive, and consequent loss of yaw control of the helicopter.

You may examine the MCAI in the AD docket at [regulations.gov](https://www.regulations.gov) under Docket No. FAA-2025-0922.

Material Incorporated by Reference under 1 CFR Part 51

The FAA reviewed Airbus Helicopters Emergency Alert Service Bulletin 05A020, Revision 3, dated September 19, 2024 (EASB 05A0020 Rev 3), which specifies procedures for repetitive inspections of the TR hub body for cracks and the TR spline flange for cracks and fretting and the appropriate corrective actions to include replacing the hub body and the splined flange. EASB 05A0020 Rev 3 also excludes helicopters that have complied with Airbus Helicopters Alert Service Bulletin EC120-64-21-0001, Issue 001, dated September 19, 2024 (ASB EC120-64-21-0001) from its effectivity and limits the effectivity for “non installed equipment or parts”.

The FAA also reviewed ASB EC120-64-21-0001, which specifies procedures for inspecting the torque applied on the nut of the link between the TR hub and the splined flange, and depending on the inspection results, applying torque and replacing parts. ASB EC120-64-21-0001 also specifies procedures for applying a red paint line on the screw, nut, washer, TR hub, and splined flange.

This material is reasonably available because the interested parties have access to it through their normal course of business or by the means identified in the ADDRESSES section.

FAA’s Determination

These products have been approved by the aviation authority of another country and are approved for operation in the United States. Pursuant to the FAA’s bilateral agreement with this State of Design Authority, it has notified the FAA of the unsafe condition described in the MCAI referenced above. The FAA is issuing this NPRM after determining that the unsafe condition described previously is likely to exist or develop on other products of the same type design.

Proposed AD Requirements in this NPRM

This proposed AD would require some of the same repetitive inspections and corrective actions as AD 2021-26-07 and would also require modifying the helicopter by applying torque and adding a red paint mark on each bolt and nut on the link between the TR hub and the splined flange after applying torque, which would be a terminating action for the repetitive inspection requirements. The proposed AD would also require repetitive inspections of the red paint line added during the modification of the link of the TR hub body for alignment.

Differences Between this Proposed AD and the MCAI

EASA AD 2024-0209 allows a non-cumulative tolerance of 100 FH [flight hours] to be applied to the compliance times to allow for synchronization of the required inspections with other maintenance tasks, whereas this proposed AD would not allow a non-cumulative tolerance to be applied to the compliance times.

Costs of Compliance

The FAA estimates that this AD, if adopted as proposed, would affect 70 helicopters of U.S. registry. Labor rates are estimated at \$85 per hour. Based on these numbers, the FAA estimates the following costs to comply with this proposed AD.

Visually inspecting a TR hub body for a crack would take 0.25 work-hour for an estimated cost of \$22 per helicopter and \$1,540 for the U.S. fleet.

Visually inspecting a TR spline flange for corrosion, impacts, fretting, wear, and a crack would take 0.25 work-hour for an estimated cost of \$22 per helicopter and \$1,540 for the U.S. fleet.

Replacing a T/R hub body bolt, washer, and nut would take 0.5 work-hour and parts would cost \$25 (per hardware set) for an estimated cost of \$68 per helicopter.

Inspecting torque and adding a red paint line on each bolt and each nut would take 4 work-hours for an estimated cost of \$340 per helicopter and \$23,800 for the U.S. fleet.

If required, replacing a TR hub body would take 2 work-hours and parts would cost \$16,485 for an estimated cost of \$16,655 per helicopter.

If required, replacing a TR spline flange would take 0.5 work-hour and parts would cost \$2,950 for an estimated cost of \$2,993 per helicopter.

Authority for this Rulemaking

Title 49 of the United States Code specifies the FAA's authority to issue rules on aviation safety. Subtitle I, section 106, describes the authority of the FAA Administrator. Subtitle VII, Aviation Programs, describes in more detail the scope of the Agency's authority.

The FAA is issuing this rulemaking under the authority described in Subtitle VII, Part A, Subpart III, Section 44701: General requirements. Under that section, Congress charges the FAA with promoting safe flight of civil aircraft in air commerce by prescribing regulations for practices, methods, and procedures the Administrator finds necessary for safety in air commerce. This regulation is within the scope of that authority because it addresses an unsafe condition that is likely to exist or develop on products identified in this rulemaking action.

Regulatory Findings

The FAA determined that this proposed AD would not have federalism implications under Executive Order 13132. This proposed AD would not have a substantial direct effect on the States, on the relationship between the national Government and the States, or on the distribution of power and responsibilities among the various levels of government.

For the reasons discussed above, I certify that the proposed regulation:

- (1) Is not a "significant regulatory action" under Executive Order 12866,
- (2) Would not affect intrastate aviation in Alaska, and
- (3) Would not have a significant economic impact, positive or negative, on a substantial number of small entities under the criteria of the Regulatory Flexibility Act.

List of Subjects in 14 CFR Part 39

Air transportation, Aircraft, Aviation safety, Incorporation by reference, Safety.

The Proposed Amendment

Accordingly, under the authority delegated to me by the Administrator, the FAA proposes to amend 14 CFR part 39 as follows:

PART 39 - AIRWORTHINESS DIRECTIVES

1. The authority citation for part 39 continues to read as follows:

Authority: 49 U.S.C. 106(g), 40113, 44701.

§ 39.13 [Amended]

2. The FAA amends § 39.13 by:

a. Removing Airworthiness Directive 2021-26-07, Amendment 39-21866 (86 FR 72829, December 23, 2021); and

b. Adding the following new airworthiness directive:

Airbus Helicopters: Docket No. FAA-2025-0922; Project Identifier MCAI-2024-00650-R.

(a) Comments Due Date

The FAA must receive comments on this airworthiness directive (AD) by [INSERT DATE 45 DAYS AFTER DATE OF PUBLICATION IN THE FEDERAL REGISTER].

(b) Affected ADs

This AD replaces AD 2021-26-07, Amendment 39-21866 (86 FR 72829, December 23, 2021).

(c) Applicability

This AD applies to Airbus Helicopters Model EC120B helicopters, certificated in any category.

(d) Subject

Joint Aircraft System Component (JASC) Code 6422, Tail rotor system.

(e) Unsafe Condition

This AD was prompted by analysis of recurrent loss of tightening torque on several attachment bolts on the tail rotor (TR) hub body. The FAA is issuing this AD to detect cracking and fretting of the TR hub body. The unsafe condition, if not addressed, could lead to loss of the TR drive, and consequent loss of yaw control of the helicopter.

(f) Compliance

Comply with this AD within the compliance times specified, unless already done.

(g) Required Actions

(1) Within 15 hours time-in-service (TIS) or 7 days, whichever occurs first after the effective date of this AD, and thereafter at intervals not to exceed 15 hours TIS, using

a light source and mirror, visually inspect TR hub body part number (P/N) C642A0100103 for a crack in the entire inspection area depicted in Figure 1 of Airbus Helicopters Emergency Alert Service Bulletin 05A020 Revision 3, dated September 19, 2024. If any crack is found, before further flight, perform the actions in paragraphs (g)(1)(i) and (ii) of this AD.

(i) Remove the TR hub body and each bolt, washer, and nut installed on the TR hub body from service and replace with airworthy parts.

(ii) Inspect the TR splined flange for corrosion, impacts, fretting, wear, and a crack in the areas identified in Figure 2 to paragraph (g)(1)(ii) of this AD. If the condition of the part (including corrosion, impacts, fretting, wear, or cracks) exceeds the criteria as specified in Figure 1 to paragraph (g)(1)(ii) of this AD, before further flight, remove the splined flange from service and replace with an airworthy part.

Note 1 to paragraph (g)(1)(ii): You may refer to “Detailed Check-Splined Flange,” Task 64-21-00, 6-5, Airbus Aircraft Maintenance Manual (AMM), dated October 15, 2020, which pertains to the TR splined flange inspection.

Figure 1 to paragraph (g)(1)(ii) – Inspection Criteria for TR Splined Flange

Location as specified in Figure 2 to paragraph (g)(1)(ii) of this AD	Maximum damage, which causes replacement (E1, Dia. 2, Dia. 3, and Dia. 4 are shown in Figure 2 to paragraph (g)(1)(ii) of this AD)
Zone A	Scratch depth > 0.2 mm (0.008 in.). Crack. E1 < 2.75 mm (0.108 in.). Dia. 3 > 6.02 mm (0.2371 in.). Dia. 2 > 33.03 mm (1.3004 in.).
Zone B	Touch-up depth > 0.1 mm (0.004 in.). Crack.
Zone C	Crack. Scratch depth > 0.2 mm (0.008 in.).

Location as specified in Figure 2 to paragraph (g)(1)(ii) of this AD	Maximum damage, which causes replacement (E1, Dia. 2, Dia. 3, and Dia. 4 are shown in Figure 2 to paragraph (g)(1)(ii) of this AD)
Zone D [Dia. 4 = 14 mm +/- 0.1 mm (0.548; 0.555in.)]	Touch-up depth > 0.1 mm (0.004 in.). Crack. E1 < 2.75 mm (0.108 in.).

Figure 2 to paragraph (g)(1)(ii) – Inspection Areas of Tail Rotor Splined Flange

Flange

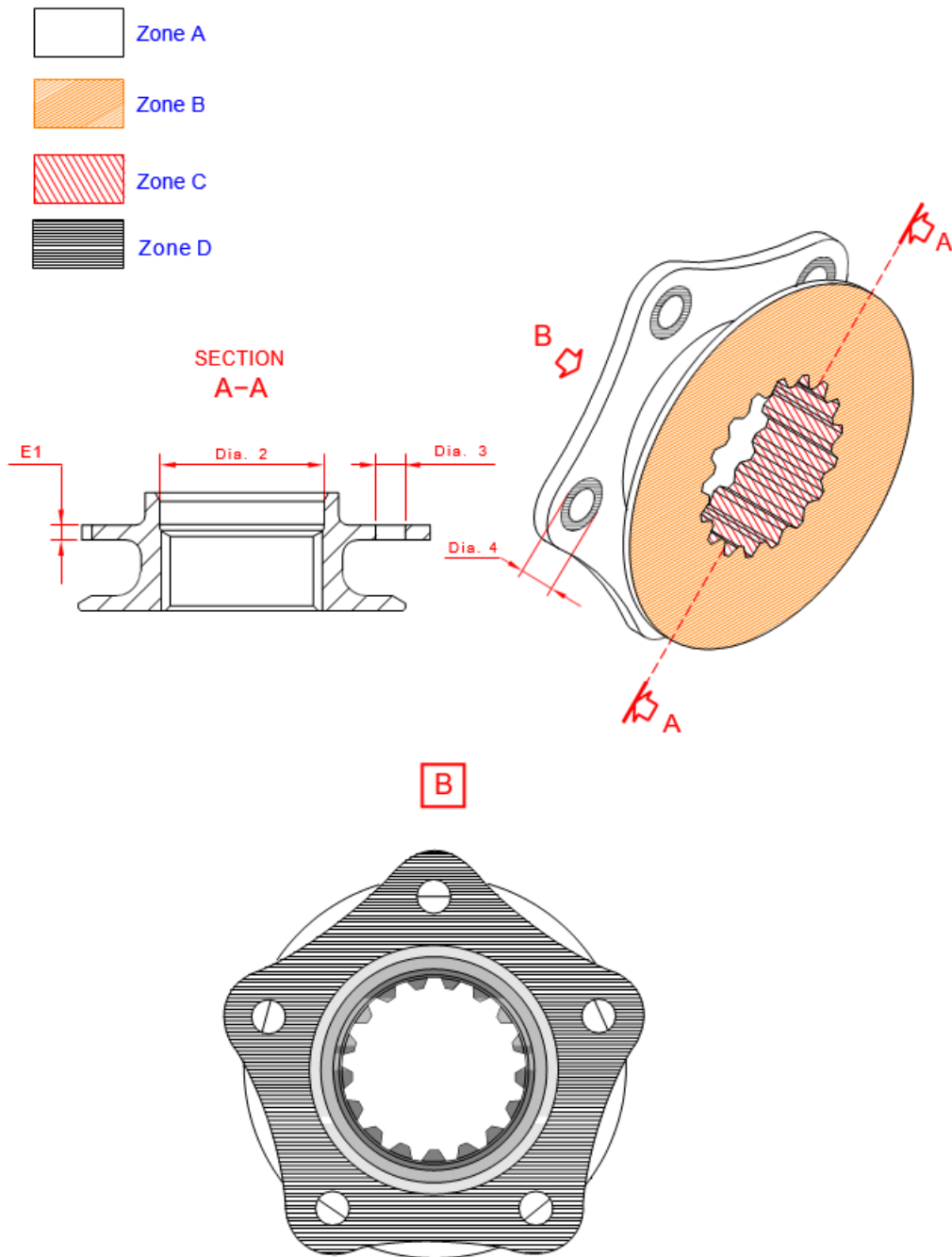

(2) For helicopters with 9,000 or more total hours TIS or with unknown total hours TIS, within 15 hours TIS or 7 days, whichever occurs first after the effective date of this AD, and thereafter at intervals not to exceed 1,000 hours TIS, remove each bolt washer, and nut installed on the TR hub body from service and replace with airworthy parts and perform the actions in paragraph (g)(1)(ii) of this AD.

(3) For helicopters with less than 9,000 total hours TIS, within 1,000 hours TIS or

before accumulating 9,000 total hours TIS, whichever occurs first after the effective date of this AD, and thereafter at intervals not to exceed 1,000 hours TIS, remove each bolt, washer, and nut installed on the TR hub body from service and replace with airworthy parts and perform the actions in paragraph (g)(1)(ii) of this AD.

(4) Within 24 months after the effective date of this AD, inspect the torque on the nut of the TR hub body in accordance with paragraph 4.1.2 of Airbus Helicopters Alert Service Bulletin ASB EC120-64-21-0001, dated September 19, 2024.

(i) If the torque is not within allowable limits, before further flight, remove the nut on the TR hub body from service and replace it with an airworthy nut; and accomplish the actions in paragraph (g)(4)(ii) of this AD.

(ii) If the torque is within allowable limits, before further flight, using polyurethane paint, apply a red paint line to the bolt and washer on the TR hub body; and apply a red paint line to the nut and washer on the splined flange. These actions terminate the repetitive inspections and replacements required by paragraphs (g)(1) through (3) of this AD.

(5) Within 100 hours TIS or 12 months, whichever occurs first after the action required in paragraph (g)(4)(ii) of this AD, and thereafter at intervals not to exceed 100 hours TIS or 12 months, whichever occurs first, inspect the red paint line for alignment. If the red paint line is misaligned, before further flight, perform the actions as specified in paragraphs (g)(4)(i) of this AD.

(h) Parts Installation Limitations

As of the effective date of this AD, do not install on any helicopter a TR hub body P/N C642A0100103 or a splined flange unless the part is new (zero hours TIS) or has passed the inspection requirements required by paragraph (g)(1) of this AD.

(i) Credit for Previous Actions

This paragraph provides credit for the initial instance of the actions required by paragraphs (g)(1) through (3) of this AD, if those actions were performed before the effective date of this AD in accordance with Airbus Helicopters Emergency Alert Service Bulletin 05A020 Revision 0, dated October 29, 2019; Revision 1, dated November 8, 2019; or Revision 2, dated February 8, 2021.

(j) Alternative Methods of Compliance (AMOCs)

(1) The Manager, International Validation Branch, FAA, has the authority to approve AMOCs for this AD, if requested using the procedures found in 14 CFR 39.19. In accordance with 14 CFR 39.19, send your request to your principal inspector or responsible Flight Standards Office, as appropriate. If sending information directly to the manager of the International Validation Branch, send it to the attention of the person identified in paragraph (k)(1) of this AD and email to: AMOC@faa.gov.

(2) Before using any approved AMOC, notify your appropriate principal inspector, or lacking a principal inspector, the manager of the responsible Flight Standards Office. The following provisions also apply to this AD.

(k) Additional Information

(1) For more information about this AD, contact Camille Seay, Aviation Safety Engineer, FAA, 1600 Stewart Avenue, Suite 410, Westbury, NY 11590; phone: (817) 222-5149; email: camille.l.seay@faa.gov.

(2) For Airbus Helicopters material identified in this AD that is not incorporated by reference, can be found at the contact information identified in paragraph (m)(3) of this AD.

(l) Material Incorporated by Reference

(1) The Director of the Federal Register approved the incorporation by reference of the material listed in this paragraph under 5 U.S.C. 552(a) and 1 CFR part 51.

(2) You must use this material as applicable to do the actions required by this AD, unless the AD specifies otherwise.

(i) Airbus Helicopters Emergency Alert Service Bulletin 05A020, Revision 3, dated September 19, 2024.

(ii) Airbus Helicopters Alert Service Bulletin EC120-64-21-0001, dated September 19, 2024.

(3) For Airbus Helicopters material identified in this AD, contact Airbus Helicopters, 2701 North Forum Drive, Grand Prairie, TX 75052; phone: (972) 641-0000 or: (800) 232-0323; fax: (972) 641-3775; website: airbus.com/en/products-services/helicopters/hcare-services/airbusworld.

(4) You may view this material at FAA, Office of the Regional Counsel, Southwest Region, 10101 Hillwood Parkway, Room 6N-321, Fort Worth, TX 76177. For information on the availability of this material at the FAA, call (817) 222-5110.

(5) You may view this material at the National Archives and Records Administration (NARA). For information on the availability of this material at NARA, visit www.archives.gov/federal-register/cfr/ibr-locations or email fr.inspection@nara.gov.

Issued on June 20, 2025.

Steven W. Thompson,
Acting Deputy Director, Compliance & Airworthiness Division,
Aircraft Certification Service.
[FR Doc. 2025-11697 Filed: 6/24/2025 8:45 am; Publication Date: 6/25/2025]