



This document is scheduled to be published in the Federal Register on 04/15/2024 and available online at <https://federalregister.gov/d/2024-07646>, and on <https://govinfo.gov>

## **National Highway Traffic Safety Administration**

### **49 CFR Part 571**

**[Docket No. NHTSA-2024-0012]**

**RIN 2127-AM43**

### **Federal Motor Vehicle Safety Standards;**

**FMVSS No. 305a Electric-powered Vehicles: Electric Powertrain Integrity**

**Global Technical Regulation No. 20,**

**Incorporation by Reference**

**AGENCY:** National Highway Traffic Safety Administration (NHTSA), Department of Transportation (DOT).

**ACTION:** Notice of proposed rulemaking (NPRM).

**SUMMARY:** Consistent with a Global Technical Regulation on electric vehicle safety, NHTSA proposes to establish Federal Motor Vehicle Safety Standard (FMVSS) No. 305a to replace FMVSS No. 305, “Electric-powered vehicles: Electrolyte spillage and electrical shock protection.” Among other improvements, FMVSS No. 305a would apply to light and heavy vehicles and would have performance and risk mitigation requirements for the propulsion battery. Relating to a National Transportation Safety Board recommendation, FMVSS No. 305a would also require manufacturers to submit standardized emergency response information for inclusion on NHTSA’s website that would assist first and second responders handling electric vehicles.

**DATES:** Comments should be submitted no later than **[INSERT DATE 60 DAYS AFTER DATE OF PUBLICATION IN THE FEDERAL REGISTER]**.

*Proposed compliance date:* We propose that the compliance date for the proposed requirements be two years after the date of publication of the final rule in the Federal Register. Small-volume

manufacturers, final-stage manufacturers, and alterers would be provided an additional year to comply with the rule beyond the date identified above. We propose to permit optional early compliance with the rule. After FMVSS No. 305a is finalized, NHTSA intends to sunset FMVSS No. 305.

**ADDRESSES:** You may submit comments identified by the docket number in the heading of this document or by any of the following methods:

- *Federal eRulemaking Portal:* Go to <http://www.regulations.gov>. Follow the instructions for submitting comments on the electronic docket site by clicking on “Help” or “FAQ.”
- *Mail:* Docket Management Facility, M-30, U.S. Department of Transportation, 1200 New Jersey Avenue S.E., West Building, Ground Floor, Room W12-140, Washington, D.C. 20590.
- *Hand Delivery:* U.S. Department of Transportation, 1200 New Jersey Avenue S.E., West Building, Ground Floor, Room W12-140, Washington, D.C. 20590 between 9 a.m. and 5 p.m. Eastern Time, Monday through Friday, except Federal Holidays.
- *Fax:* 202-493-2251.

*Instructions:* All submissions must include the agency name and docket number. Note that all comments received will be posted without change to <http://www.regulations.gov>, including any personal information provided. Please see the Privacy Act discussion below. We will consider all comments received before the close of business on the comment closing date indicated above. To the extent possible, we will also consider comments filed after the closing date.

*Docket:* For access to the docket to read background documents or comments received, go to [www.regulations.gov](http://www.regulations.gov) at any time or to 1200 New Jersey Avenue SE, West Building Ground Floor, Room W12–140, Washington, DC 20590, between 9 a.m. and 5 p.m., Monday through Friday, except Federal Holidays. Telephone: 202–366–9826.

*Confidential Business Information:* If you claim that any of the information in your comment (including any additional documents or attachments) constitutes confidential business information within the meaning of 5 U.S.C. 552(b)(4) or is protected from disclosure pursuant to 18 U.S.C. 1905, please see the detailed instructions given under the Public Participation heading of the SUPPLEMENTARY INFORMATION section of this document.

*Privacy Act:* In accordance with 5 U.S.C. 553(c), DOT solicits comments from the public to better inform its decision-making process. DOT posts these comments, without edit, including any personal information the commenter provides, to *www.regulations.gov*, as described in the system of records notice (DOT/ALL-14 FDMS), which can be reviewed at *www.transportation.gov/privacy*. In order to facilitate comment tracking and response, we encourage commenters to provide their name, or the name of their organization; however, submission of names is completely optional. Whether or not commenters identify themselves, all timely comments will be fully considered.

**FOR FURTHER INFORMATION CONTACT:** For technical issues, you may contact Ms. Lina Valivullah, Office of Crashworthiness Standards; Telephone: 202-366-8786; Email: *Lina.Valivullah@dot.gov*; Facsimile: (202) 493-2739. For legal issues, you may contact Ms. K. Helena Sung, Office of Chief Counsel; Telephone: 202-366-2992; Email: *Helena.Sung@dot.gov*; Facsimile: (202) 366-3820. The mailing address of these officials is: National Highway Traffic Safety Administration, 1200 New Jersey Avenue, S.E., Washington, D.C. 20590.

**SUPPLEMENTARY INFORMATION:**

**Table of Contents**

**I. Executive Summary**

**II. Background**

**a. Overview of FMVSS No. 305**

**b. Overview of GTR No. 20**

1. The GTR Process
2. GTR No. 20

**III. Proposals Based on GTR No. 20**

**a. Expanding Applicability of FMVSS No. 305a to Heavy Vehicles**

1. Heavy School Buses
2. Heavy Vehicles Other than School Buses
  - i. Request for Comment; Mechanical Integrity Test
  - ii. Request for Comment; Mechanical Shock Test

**b. General Specifications Relating to Crash Testing**

1. Low Energy Option for Capacitors
2. Assessing Fire or Explosion in Vehicle Post-Crash Test
3. Assessing Post-Crash Voltage Measurements
4. Electrolyte Spillage Versus Leakage

**c. REESS Requirements Applicable to All Vehicles**

1. Vehicle Controls for Safe REESS Operation
  - i. Overcharge Protection

- ii. Over-discharge Protection
- iii. Overcurrent Protection
- iv. Over-temperature Protection
- v. External Short-circuit Protection
- vi. Low-temperature Protection

2. Mitigating Risk of Thermal Propagation Due to Internal Short within a Single Cell in the REESS

- i. Safety Need
- ii. GTR No. 20 Phase 1 Requirements
- iii. NHTSA Proposal

3. Warning Requirements for REESS Operations

- i. Thermal Event Warning
- ii. Warning in the Event of Operational Failure of REESS Vehicle Controls

4. Protection Against Water Exposure

- i. NHTSA Proposal
  - A. Vehicle Washing Test
  - B. Driving Through Standing Water Test
- ii. NHTSA's Consideration of Submersions

5. Miscellaneous GTR No. 20 Provisions Not Proposed

- i. REESS Vibration Requirements
- ii. REESS Thermal Shock and Cycling

iii. REESS Fire Resistance

iv. Low State-of-Charge (SOC) Telltale

#### **IV. Request for Comment on Applying FMVSS No. 305a to Low-Speed Vehicles**

#### **V. Emergency Response Information to Assist First and Second Responders**

#### **VI. Request for Comment on Placing the Emergency Response Information and Documentation Requirements in a Regulation rather than in FMVSS No. 305a**

#### **VII. Proposed Compliance Dates**

#### **VIII. Rulemaking Analyses and Notices**

#### **IX. Public Participation**

#### **X. Appendices to the Preamble**

APPENDIX A. Table Comparing GTR No. 20, FMVSS No. 305, and FMVSS No. 305a

APPENDIX B. Request for Comment on Phase 2 GTR No. 20 Approaches Under Consideration by the IWG

##### **I. Executive Summary**

NHTSA is issuing this NPRM to achieve two goals. First, NHTSA proposes to establish FMVSS No. 305a, “Electric-powered Vehicles: Electric Powertrain Integrity,” to upgrade and

replace existing FMVSS No. 305. Proposed FMVSS No. 305a would have all the requirements of FMVSS No. 305, but the proposed standard would expand its applicability to vehicles with a gross vehicle weight rating (GVWR) greater than 4,536 kilograms (kg) (10,000 pounds (lb)) and add requirements and test procedures covering new aspects of electric vehicle safety, such as the performance and risk mitigation requirements for the propulsion battery, referred to as the Rechargeable Electrical Energy Storage System (REESS). NHTSA is also proposing requirements to ensure first and second responders have access to vehicle-specific information about extinguishing REESS fires and mitigating safety risks associated with stranded energy<sup>1</sup> when responding to emergencies. The restructured and upgraded FMVSS No. 305a will facilitate future updates to the standard as battery technologies and charging systems continue to evolve. After FMVSS No. 305a is finalized, NHTSA intends to sunset FMVSS No. 305.

The second goal is to further NHTSA's effort to harmonize the Federal Motor Vehicle Safety Standards under the Economic Commission for Europe 1998 Global Agreement ("1998 Agreement"). The efforts of the U.S. and other contracting parties to the 1998 Agreement culminated in the establishment of Global Technical Regulation (GTR) No. 20, "Electric Vehicle Safety."<sup>2</sup> FMVSS No. 305 already incorporates a substantial portion of GTR No. 20's requirements due to a previous NHTSA rulemaking. In 2017, NHTSA amended FMVSS No. 305 to include electrical safety requirements from GTR No. 13, "Hydrogen and fuel cell vehicles," pertaining to electric vehicle performance during normal vehicle operation and post-crash.<sup>3</sup> Because GTR No. 13's provisions for electric vehicles were later incorporated into what would become GTR No. 20, the 2017 final rule that adopted GTR No. 13's provisions adopted what later became many of the requirements of GTR No. 20. That 2017 rulemaking, however, did not

---

<sup>1</sup> Stranded energy is the energy remaining inside the REESS after a crash or other incident.

<sup>2</sup> GTR No. 20, <https://unece.org/fileadmin/DAM/trans/main/wp29/wp29wgs/wp29gen/wp29registry/ECE-TRANS-180a20e.pdf>.

<sup>3</sup> GTR No. 13 only applied to light vehicles. Normal vehicle operations include operating modes and conditions that can reasonably be encountered during typical operation of the vehicle, such as driving, parking, standing in traffic with vehicle in drive mode, and charging. Final rule, 82 FR 44950, September 27, 2017.

expand the applicability of FMVSS No. 305 to include heavy vehicles nor did it include requirements for the REESS. This NPRM proposes these and other GTR No. 20 requirements.

### **High Level Summary of the Proposal**

FMVSS No. 305 currently only applies to passenger cars and to multipurpose passenger vehicles, trucks, and buses with a GVWR of 4,536 kg (10,000 lb) or less (“light vehicles”).

Consistent with GTR No. 20, proposed FMVSS No. 305a expands the current applicability of FMVSS No. 305 to vehicles with a GVWR greater than 4,536 kg (10,000 lb) (“heavy vehicles”).

Under proposed FMVSS No. 305a:

- Light vehicles would be subject to requirements carried over from FMVSS No. 305 that ensure the safety of the electrical system during normal vehicle operations and after a crash (post-crash).<sup>4</sup> They would also be subject to new requirements for the REESS.
- Heavy vehicles would be subject to the requirements for electrical system safety during normal vehicle operations and to requirements for the REESS. However, except for heavy school buses, they would not be subject to post-crash requirements. This proposed exclusion of heavy vehicles, other than school buses, from crash tests, aligns with similar exclusions in FMVSS No. 301, “Fuel system integrity,” for conventional fuel vehicles and FMVSS No. 303, “Fuel system integrity of compressed natural gas vehicles,” for compressed natural gas vehicles.
- Heavy school buses (GVWRs greater than 4,536 kg (10,000 lb))<sup>5</sup> would be subject to the requirements for electrical system safety during normal vehicle operations and to the requirements for the REESS, and would have to meet post-crash test requirements to ensure the vehicles protect against unreasonable risk of electric shock and risk of

---

<sup>4</sup> Current FMVSS No. 305 light vehicle post-crash test requirements (front, side, and rear crashes) are aligned with FMVSS No. 301’s light vehicle post-crash test requirements.

<sup>5</sup> In the school bus safety area, stakeholders, including NHTSA, commonly refer to buses with a GVWR over 4,536 kg (10,000 lb) as “large” school buses.

fire after a crash. The post-crash tests are the same tests described in FMVSS No. 301 for heavy school buses (impacted at any point and at any angle by a moving contoured barrier).

The post-crash requirements of proposed FMVSS No. 305a for light vehicles and heavy school buses include electric shock protection (there are four compliance options – low voltage, electrical isolation, protective barrier, and low energy for capacitors<sup>6</sup>); REESS retention; electrolyte leakage; and fire safety. The requirements for REESS retention and electrolyte leakage are already in FMVSS No. 305, but this NPRM proposes to enhance some provisions consistent with GTR No. 20. For example, current FMVSS No. 305 does not specify that there must be no fire or explosion after a crash test. Electric vehicles may catch fire long after a collision or other occurrence resulting in a fault condition. To account for the potential delayed response, NHTSA is proposing to prohibit fire or explosion for a one-hour post-test period.

A substantial portion of this NPRM focuses on safety provisions for the propulsion battery, the REESS. For what would be the first time in an FMVSS, proposed FMVSS No. 305a includes comprehensive performance requirements and risk mitigation strategies for the REESS. These REESS requirements would apply to all vehicles, regardless of GVWR. A REESS provides electric energy for propulsion and may include necessary ancillary systems for physical support, thermal management, electronic controls, and casings. The proposed requirements set a level of protection of the REESS against external fault inputs, ensure the REESS operations are within the manufacturer-specified functional range, and increase the likelihood of safe operation of the REESS and other electrical systems of the vehicle during and after water exposure during normal vehicle operations.<sup>7</sup>

---

<sup>6</sup> FMVSS No. 305 already includes the first three compliance options for electrical shock protection but not the low energy option that is available for capacitors in GTR No. 20. This NPRM would complete the alignment by proposing the low energy option for capacitors in FMVSS No. 305a. NHTSA had considered this option years ago and had decided against it. As explained in detail in sections below, NHTSA has changed its view on the matter after further considering data and analysis from the GTR.

<sup>7</sup> “Normal vehicle operation” means situations such as driving through a pool of standing water or exposing the vehicle to an automated car wash. This NPRM does not propose requirements to address vehicle fires due to

Proposed FMVSS No. 305a addresses some aspects of REESS safety through documentation measures, consistent with GTR No. 20. “Documentation measures” means a list of information provided by manufacturers, at NHTSA's request, that demonstrate that they considered, assessed, and mitigated identified risks for safe operation of the vehicle. These proposed documentation requirements would address: (a) safety risk mitigation associated with charging and discharging during low temperature; (b) the safety risks from thermal propagation in the event of single-cell thermal runaway<sup>8</sup> (SCTR) due to an internal short-circuit of a single cell; and (c) providing a warning if there is a malfunction of vehicle controls that manage REESS safe operation. The GTR takes a documentation approach on these aspects of safety because of the rapidly evolving electric vehicle technologies and the variety of available REESS and electric vehicle designs. The Informal Working Group experts that drafted the GTR determined there currently are no objective test procedures to evaluate safety risk mitigation designs or the operations of warnings of a malfunction of vehicle controls in a manner that is not design restrictive.

NHTSA tentatively agrees with this approach given the current state of knowledge. Thus, until test procedures and performance criteria can be developed for all vehicle powertrain architectures, proposed FMVSS No. 305a would require manufacturers to submit documentation to NHTSA, at NHTSA’s request, that identify all known safety hazards, describe their risk mitigation strategies for the safety hazards, and, if applicable, describe how they provide a warning to address a safety hazard.<sup>9</sup> The purpose of the documentation approach is two-fold. Given the variation of battery design and design specific risk mitigation systems, the documentation requirement would be a means of assuring that each manufacturer has identified

---

vehicle submersions in floods and storm surges, as GTR No. 20 does not have specific requirements to address this area. NHTSA is researching this latter area.

<sup>8</sup> Thermal runaway means an uncontrolled increase of cell temperature caused by exothermic reactions inside the cell.

<sup>9</sup> Section 30166 of the Vehicle Safety Act authorizes the Secretary of Transportation (NHTSA by delegation) the ability to request and inspect manufacturer records that are necessary to enforce the prescribed regulations.

safety risks and safety risk mitigation strategies. The requirement provides a means for NHTSA to learn of the risks associated with the REESS, understand how the manufacturer is addressing the risks, and oversee those safety hazards. This approach is battery technology neutral, not design restrictive, and is intended to evolve over time as battery technologies continue to rapidly evolve. It is an interim measure intended to assure that manufacturers will identify and address the safety risks of the REESS until such time objective performance standards can be developed that can be applied to all applicable REESS designs. NHTSA would also acquire information from the submissions to learn about the safety of the REESS and potentially develop the future performance standards for FMVSS No. 305a. The proposed documentation requirements are based on the approach of GTR No. 20, but NHTSA proposes to focus the GTR's documentation requirements to enable the agency to obtain more targeted information from manufacturers.<sup>10</sup>

As part of NHTSA's battery initiative<sup>11</sup> and in response to a 2020 NTSB recommendation,<sup>12</sup> this NPRM proposes to include in FMVSS No. 305a a requirement that vehicle manufacturers submit to NHTSA emergency response guides (ERGs) and rescue sheets for each vehicle make, model, and model year. The purpose of the requirement is to provide information to first<sup>13</sup> and second<sup>14</sup> responders regarding the safe handling of the vehicle in emergencies and for towing and storing operations. The uploaded ERGs and rescue sheets would be publicly available on NHTSA's website for easy searchable access. ERGs and rescue sheets communicate vehicle-specific information related to fire, submersion, and towing, as well as the location of components in the vehicle that may expose the vehicle occupants or rescue personnel

---

<sup>10</sup> Given the proposed documentation specifications are more akin to disclosure requirements that could be issued under general NHTSA regulation rather than pursuant to an FMVSS with specified test procedures, the agency also requests comment on whether the proposed documentation requirements would be better placed in a general agency regulation than in the proposed FMVSS No. 305a.

<sup>11</sup> <https://www.nhtsa.gov/battery-safety-initiative>

<sup>12</sup> "Safety risks to emergency responders from lithium-ion battery fires in electric vehicles," Safety Report NTSB/SR-20/01, PB2020-101011, National Transportation Safety Board, <https://www.nts.gov/safety/safety-studies/Documents/SR2001.pdf>.

<sup>13</sup> "First responder" means a person with specialized training such as a law enforcement officer, paramedic, emergency medical technician, and/or firefighter, who is typically one of the first to arrive and provide assistance at the scene of an emergency.

<sup>14</sup> "Second responder" means a worker who supports first responders by cleaning up a site, towing vehicles, and/or returning services after an event requiring first responders.

to risks, the nature of a specific function or danger, and devices or measures which inhibit a dangerous state.

NHTSA would require standardized formatting of the information. The ERG and rescue sheet requirements would meet the layout and format specified in ISO-17840, “Road vehicles – Information for first and second responders,” which standardize color-coded sections in a specific order to help first and second responders quickly identify pertinent vehicle-specific rescue information. The standardized information would be available and understandable to first and second responders so they can easily refer to vehicle-specific rescue information en route to or at the scene of a crash or fire event and respond to the emergency quickly and safely.

NHTSA believes there are no notable costs associated with this NPRM. This proposal closely mirrors the electrical safety provisions of GTR No. 20, which have been voluntarily implemented by manufacturers in this country. The agency believes that the proposed safety standards are widely implemented by manufacturers of light and heavy electric vehicles and heavy electric school buses. Manufacturers are also already providing emergency response information to the National Fire Protection Association (NFPA); under proposed FMVSS No. 305a they would just have to standardize the format and submit the information to NHTSA.<sup>15</sup>

Lastly, current FMVSS No. 305 does not apply to vehicles that travel under 40 km/h (25 mph), such as low-speed vehicles.<sup>16</sup> Given there are low-speed vehicles that are also electric-powered vehicles, NHTSA requests comments on the possibility of applying aspects of FMVSS No. 305a to low-speed vehicles to ensure a level of protection against shock and fire, particularly during normal vehicle operation, and to assure the safe operation of the REESS.

---

<sup>15</sup> Similar to the issue discussed above regarding having the proposed documentation requirements in a general regulation rather than in FMVSS No. 305a, the agency also requests comment on whether the proposed ERG and rescue sheet requirements would be better placed in a general agency regulation than in proposed FMVSS No. 305a.

<sup>16</sup> “Low-speed vehicle” is defined in 49 CFR 571.3. See also FMVSS No. 500, “Low speed vehicles,” 49 CFR 500.

## II. Background

### a. Overview of FMVSS No. 305

The purpose of FMVSS No. 305, “Electric-powered vehicles: electrolyte spillage and electrical shock protection,” is to reduce deaths and injuries from electrical shock. The standard applies only to light vehicles (vehicles with a GVWR less than or equal to 4,536 (kg) (10,000 (lb))). The standard’s requirements reduce the risk of harmful electric shock: (a) during normal vehicle operation;<sup>17</sup> and (b) in post-crash situations (to protect vehicle occupants, and rescue workers and others who may come in contact with the vehicle after a crash). The standard’s requirements for the former protect against direct and indirect contact of high voltage sources during everyday operation of the vehicles. The focus of this “in-use” testing (unlike “post-crash” testing, discussed below) deals with performance criteria that would be assessed without first exposing the vehicle to a crash test.

**Normal Vehicle Operations.** FMVSS No. 305 requires vehicles to provide the following measures to protect against electric shock during normal vehicle operations. Vehicles must prevent direct contact of high voltage sources (those operating with voltage greater than 30 VAC or 60 VDC)<sup>18</sup>; prevent indirect contact of high voltage sources; electrically isolate high voltage sources from the electric chassis (500 ohms/volt or higher for alternating current (AC) and 100 ohms/volt or higher for direct current (DC) sources); mitigate risk of driver error (indicate to the driver when the vehicle is in possible active driving mode at startup and when the driver is leaving the vehicle, and prevent vehicle movement by its own propulsion system when the vehicle charging system is connected to the external electric power supply).

**Post-Crash Protections.** For post-crash protections, FMVSS No. 305 requires vehicles to meet the following provisions during and after the crash tests specified in the standard.

---

<sup>17</sup> Normal vehicle operation includes operating modes and conditions that can reasonably be encountered during typical operation of the vehicle, such as driving, parking, and standing in traffic, as well as charging using chargers that are compatible with the specific charging ports installed on the vehicle. It does not include conditions where the vehicle is damaged, either by a crash or road debris, subjected to fire or water submersion, or in a state where service and/or maintenance is needed or being performed.

<sup>18</sup> VAC – volts of alternating current; VDC – volts of direct current.

FMVSS No. 305 limits electrolyte spillage from propulsion batteries and requires the REESS to remain attached to the vehicle and not enter the passenger compartment. The standard requires that during and after a crash test, high voltage sources in a vehicle must be either electrically isolated from the vehicle's chassis; of a voltage below specified levels considered safe from electric shock hazards; or prevented from direct or indirect contact by occupants or emergency services personnel by use of physical barriers. The standard specifies that the post-crash requirements must be met after crash tests involving: a frontal impact up to and including 48 kilometer per hour (km/h) (30 mile per hour (mph)) into a fixed collision barrier; an impact of a moving barrier at 80 km/h (50 mph) into the rear of the vehicle; an impact of a moving barrier at 53 km/h (33 mph) into the side of the vehicle; and under static rollover conditions after each such impact.

FMVSS No. 305 already has many of GTR No. 20's requirements for light vehicles, including requirements for electrical safety during normal vehicle operation; post-crash electrolyte spillage; post-crash REESS retention; and most of the GTR's post-crash electrical safety options for high voltage sources.

## **b. Overview of GTR No. 20**

### **1. The GTR Process**

The United States is a contracting party to the "1998 Agreement" (the Agreement concerning the Establishing of Global Technical Regulations for Wheeled Vehicles, Equipment and Parts which can be fitted and/or be used on Wheeled Vehicles). This agreement entered into force in 2000 and is administered by the UN Economic Commission for Europe's (UN ECE's) World Forum for the Harmonization of Vehicle Regulations (WP.29). The purpose of this agreement is to establish Global Technical Regulations (GTRs).

In March 2012, UNECE WP.29 formally adopted the proposal to establish GTR No. 20 at its one-hundred-and-fifty-eighth session. NHTSA chaired the development of GTR No. 20 and voted in favor of establishing GTR No. 20.

As a Contracting Party Member to the 1998 Global Agreement who voted in favor of GTR No. 20, NHTSA is obligated to initiate the process used in the U.S. to adopt the GTR as an agency regulation. By issuing this NPRM, NHTSA is initiating the process to consider adoption of GTR No. 20. As noted above, under the terms of the 1998 Agreement, NHTSA is not obligated to adopt the GTR after initiating this process. In deciding whether to adopt a GTR as an FMVSS, NHTSA follows the requirements for NHTSA rulemaking, including the Administrative Procedure Act, the National Traffic and Motor Vehicle Safety Act (Vehicle Safety Act), Presidential Executive Orders, and DOT and NHTSA policies, procedures, and regulations. Among other things, FMVSSs issued under the Vehicle Safety Act “shall be practicable, meet the need for motor vehicle safety, and be stated in objective terms.”<sup>19</sup>

## **2. GTR No. 20**

GTR No. 20 establishes performance-orientated requirements that reduce potential safety risks of electric vehicles (EVs) while in use and after a crash event. The GTR includes provisions that address electrical shock associated with high voltage circuits of EVs and potential hazards associated with lithium-ion batteries and/or other REESS. One of the principles for developing GTR No. 20 was to address unique safety risks posed by electric vehicles and their components to ensure a safety level equivalent to conventional vehicles with internal combustion engines.

The requirements in GTR No. 20 were developed in Phase 1 of the GTR. GTR No. 20 was developed in phases due to the differing stages at which technologies have been developed and evaluated. The informal working group (IWG) that developed the GTR determined that Phase 1 would address issues relating to the safe operation of the rechargeable electrical energy storage system (REESS), and for mitigating risks of fire and other safety risks associated with the REESS. In Phase 2, which is on-going, the IWG is addressing issues involving long-term

---

<sup>19</sup> 49 U.S.C. 30111.

research and verification.<sup>20</sup> This NPRM pertains to the adoption of the GTR as developed in Phase 1.

GTR No. 20 applies to all electric-powered vehicles regardless of GVWR, in contrast to FMVSS No. 305, which only applies to light vehicles. FMVSS No. 305 currently includes the majority of GTR No. 20's requirements and applies these to light vehicles. GTR No. 20 also has safety requirements for the REESS beyond those in FMVSS No. 305. These additional requirements in GTR No. 20 for the REESS include:

- Safe operation of REESS under the following exposures during normal vehicle operations:
  - REESS protection under external fault conditions and extreme operating temperatures:
    - External short circuit
    - Overcharge
    - Over-discharge
    - Overcurrent
    - High operating temperature
    - Low operating temperature
  - Management of REESS emitted gases
  - Water exposure during vehicle washing and driving through 10-centimeter (cm) deep water on roadway.
  - Thermal shock and cycling (-40°C to 60°C)\*<sup>21</sup>
  - Resistance to short duration external gasoline pool fire\*

---

<sup>20</sup> In Appendix B to this preamble, NHTSA requests comments on some issues under development in Phase

<sup>21</sup> The asterisk notes that this NPRM is not proposing to adopt the GTR No. 20 requirement.

- Vibration environment during normal vehicle operations\*
  
- Warning systems for REESS safe operation in case of:
  - Low energy content in REESS\*<sup>22</sup>
  - REESS control operational failure
  - Thermal runaway propagation due to single cell short circuit in REESS
  - Thermal event in REESS
  
- Installation (location) of REESS on the vehicle<sup>23</sup>

This NPRM proposes to complete the alignment of FMVSS No. 305 with GTR No. 20 by extending the standard's electrical safety requirements to heavy vehicles. This NPRM also proposes to adopt the above requirements for the REESS to light and heavy vehicles, except as noted by an asterisk, because requirements for thermal shock and cycling, resistance to short duration external pool fire, and vibration environment are already included under United States Hazardous Materials Regulations (HMR), 49 CFR parts 171 to 180, in accordance with the international lithium battery transportation requirements of UN 38.3, "Transport of dangerous goods: Manual of tests and criteria." To avoid redundancy, NHTSA is not proposing adding these requirements into FMVSS No. 305a. NHTSA explains the bases for the proposals and, for provisions not proposed, the reasons the agency has not proposed them in this NPRM.

GTR No. 20 includes post-crash requirements but does not specify the crash tests for post-crash evaluation. Instead, the GTR allows contracting parties to apply the crash tests in their

---

<sup>22</sup> This NPRM does not propose to require a warning for low energy in REESS. There is no such warning requirement for conventional fuel vehicles in the event of low-fuel, yet all conventional fuel vehicles have a low fuel indicator because it is a consumer convenience feature. The agency expects that, similarly, a low energy in REESS indicator will be voluntarily provided in all electric-powered vehicles.

<sup>23</sup> This requirement is intended for countries with type approval systems where a generic REESS can be approved separate from the vehicle. A vehicle with a pre-approved REESS that complies with the REESS installation requirement would not have to undergo post-crash safety assessment for approval. This installation requirement would not apply in the U.S. with a self-certification system.

regulations. Further, the GTR allows contracting parties to permit regulated entities to comply with post-crash requirements without conducting vehicle crash tests. In place of crash tests, a contracting party may specify tests for “mechanical integrity” and “mechanical shock” of the REESS. The mechanical integrity test uses a quasi-static load of 100 kN on the REESS to evaluate the safety performance of the REESS under contact loads that may occur during vehicle crash. The mechanical shock test accelerates the REESS on a sled system to evaluate the safety performance of the REESS and the integrity of the REESS mounting structures to the vehicle under inertial loads that may occur. NHTSA discusses its assessment of the component level mechanical integrity and mechanical shock test procedures and requests comment on these issues later in this NPRM.

### **III. Proposals Based on GTR No. 20**

#### **a. Expanding Applicability of FMVSS No. 305a to Heavy Vehicles**

NHTSA proposes to harmonize the application of FMVSS No. 305a with GTR No. 20.

Currently, FMVSS No. 305 applies to electric-powered vehicles with a GVWR less than or equal to 4,536 kg (10,000 lb); it does not apply to electric vehicles with a GVWR greater than 4,536 kg (10,000 lb). GTR No. 20 applies to both light and heavy electric vehicles. NHTSA proposes to apply FMVSS No. 305a to both light and heavy electric vehicles. The fundamentals for protecting against an electrical shock for light vehicles are the same as for heavy vehicles. A failure of a high voltage system may cause injurious electric shock to the human body.

Specifically, NHTSA proposes to apply FMVSS No. 305a to all passenger cars, multipurpose passenger vehicles, trucks, and buses, regardless of their GVWR, that use electrical propulsion components with working voltages greater than or equal to 60 VDC or 30 VAC, and whose speed attainable over a distance of 1.6 kilometers (km) (1 mile) on a paved level surface is more than 40 km/h (25 miles per hour (mph)).<sup>24</sup> The NPRM proposes to carry over the current requirements for light vehicles in FMVSS No. 305 to FMVSS No. 305a, except some provisions

---

<sup>24</sup> Current FMVSS No. 305 does not apply to these vehicles that travel under 40 km/h (25 mph).

as enhanced by this NPRM if adopted by a final rule. To sum, light vehicles would have to meet the requirements for normal vehicle operations and the requirements proposed in this NPRM for the REESS. Further, they would have to meet requirements for post-crash protections following a crash test. Under proposed FMVSS No. 305a, heavy school buses would have to meet the requirements for normal vehicle operations and for the REESS, and, following a specific crash test, requirements for post-crash protections. The agency is not adopting the provision in GTR No. 20 that conducts mechanical integrity and mechanical shock tests (component-level) for light vehicles and for heavy school buses. NHTSA believes that post-crash safety is better evaluated at a system level in a crash test than in component-level tests. Currently there are crash tests for light vehicles and school buses, thus, NHTSA proposes to conduct post-crash safety after the specified crash tests.

Heavy vehicles other than heavy school buses would be subject to the requirements for normal vehicle operations described above and the requirements for the REESS. They would not be subject to crash testing requirements because the agency does not know of a crash test that would be appropriate for the vehicles at this time. However, while NHTSA does not have a sufficient basis to proceed currently with dynamic or quasi-static requirements for heavy vehicles other than school buses, this NPRM requests comment on this issue. NHTSA is interested in the merits of component-level tests that are representative of impact loads in heavy vehicle crashes and the appropriateness of applying the tests to different weight classes of heavy vehicles. Even in the absence of post-crash testing requirements, NHTSA tentatively concludes that meeting requirements for normal vehicle operations and for the REESS, as a starting point, will enhance the safety of these heavy electric vehicles.

### **1. Heavy School Buses**

NHTSA proposes to distinguish heavy school buses from other types of heavy vehicles and subject them to crash testing because the school vehicles will be carrying children. This NPRM proposes to assess the post-crash safety of heavy school buses (school buses with a

GVWR greater than 4,536 kg (10,000 lb)) in a dynamic moving contoured barrier test. This proposal would be consistent with current school bus safety standards. FMVSS No. 301, “Fuel system integrity,” and FMVSS No. 303, “Fuel system integrity of compressed natural gas vehicles,” require heavy school buses using conventional fuel or compressed natural gas for propulsion, respectively, to maintain fuel system integrity in a crash test where a moving contoured barrier traveling at any speed up to 48 km/h (30 mph) impacts the school bus at any point and angle. These standards set this high level of safety for heavy school buses even though FMVSS Nos. 301 and 303 do not apply to other types of heavy vehicles.

NHTSA recognizes that FMVSS No. 305 currently does not apply to nor has a crash test requirement for heavy school buses. When FMVSS No. 305 was first promulgated in September 2000, NHTSA decided not to apply proposed FMVSS No. 305 to heavy school buses. NHTSA made this decision after agreeing with commenters that applying the standard to the vehicles at that time could have substantial effect, in terms of cost and weight, on heavy school buses and potentially restrict further development.<sup>25</sup> The prevailing technology at that time was a series of conventional lead-acid batteries as the energy source for propulsion. Since the 1990s and early 2000s, battery technology and electric powertrains have evolved to include nickel metal hydride and lithium-ion batteries for electric vehicles. The weight and cost concerns raised for electric school buses in 2000 are no longer obstacles with current lithium-ion battery technologies because of their high energy density and their widespread use. Several school bus manufacturers are currently manufacturing and offering for sale heavy school buses with high voltage electric propulsion systems. Given the development of the technology and practicability of designing and producing heavy electric school buses, NHTSA tentatively concludes it is appropriate to adopt requirements to ensure post-crash safety of heavy electric school buses and maintain the current high level of safety of heavy school buses.

---

<sup>25</sup> Final rule, 65 FR 57980, September 27, 2000.

NHTSA is proposing to include in FMVSS No. 305a a requirement that heavy school buses with high voltage electric propulsion systems meet the requirements for normal vehicle operations (assessed prior to a crash test) and the proposed post-crash electrical safety requirements when impacted by the moving contoured barrier specified in FMVSS No. 301. The crash test requirement would align FMVSS No. 305a's requirements for heavy school buses with those of FMVSS Nos. 301 and 303. Due to the number of electric school bus manufacturers and sales since 2000, NHTSA tentatively concludes that meeting the proposed standard would have no substantial effect on cost and weight due to widespread use of lithium-ion battery and conformance to the proposed post-crash safety requirements.<sup>26</sup>

## **2. Heavy Vehicles Other than School Buses**

There are currently no heavy vehicle crash tests in FMVSS. Heavy vehicles are typically made to order with different configurations<sup>27</sup> based on the operational needs of the purchaser and are produced in low volume. Conducting crash tests of various design configurations from a small volume of representative vehicles would be cost prohibitive. There could also be practicability constraints for conducting crash tests on higher weight classes of heavy vehicles.

In this NPRM, NHTSA has proposed requirements to ensure post-crash safety using full vehicle crash tests for light vehicles and heavy school buses. Such full vehicle crash tests evaluate post-crash safety at a system level, so NHTSA is not considering component-level tests of the REESS for those vehicles. However, since there are no full vehicle crash tests currently in FMVSSs for heavy vehicles (other than heavy school buses), NHTSA seeks comment on considerations for component-level tests (other than the mechanical integrity and mechanical

---

<sup>26</sup> Currently, all major school bus manufacturers (Blue Bird, IC Bus, Thomas Built) are offering large and small electric school buses (see AFDC- electric school bus) and many school districts have introduced electric powered school buses in their fleets. As of June 2023, there are 2,277 electric school buses that are either on order, delivered or operating in the U.S. In total, there are now 5,982 committed electric school buses in the U.S. <https://www.wri.org/insights/where-electric-school-buses-us#:~:text=As%20of%20June%202023%2C%20there,more%20buses%20since%20June%202022> .

<sup>27</sup> These differences include the number of fuel containers and battery packs and the location and attachment of fuel lines and fuel containers.

shock tests in GTR No. 20) that are representative of impact loads in heavy vehicle crashes and that can be applied to different weight classes of heavy vehicles.

**i. Request for Comment; Mechanical Integrity Test**

There are currently no crash tests specified in the FMVSSs<sup>28</sup> for evaluating the integrity of the fuel system or propulsion system of heavy vehicles other than heavy school buses. GTR No. 20 provides an option for evaluating post-crash safety of light vehicles by way of a mechanical integrity test (crush test) of the REESS as an item of vehicle equipment, instead of a full vehicle crash test as in FMVSS No. 305. The loads in the mechanical integrity requirements in the GTR No. 20 were derived from REESS contact loads measured in light passenger vehicle crash tests per UN Regulations ECE R. No. 12, “Uniform provisions concerning the approval of vehicles with regard to the protection of the driver against the steering mechanism in the event of impact,” ECE R.94, “Uniform provisions concerning the approval of vehicles with regard to the protection of the occupants in the event of a frontal collision,” and ECE R.95, “Uniform provisions concerning the approval of vehicles with regard to the protection of occupants in the event of a lateral collision,” using electric and hybrid-electric vehicles available on the market.

In the mechanical integrity test, a quasi-static load is applied to the charged REESS<sup>29</sup> along with any subsystem components (including crush protection systems specified by the manufacturer) along the longitudinal axis of the vehicle (along the direction of vehicle travel) or the lateral axis (perpendicular to the longitudinal axis). A peak load of 100 kN is applied within 3 minutes and maintained for at least 100 milliseconds. During the integrity test, the REESS is required to have no evidence of electrolyte leakage, fire, or explosion. The REESS is required to

---

<sup>28</sup> FMVSS No. 301, “Fuel system integrity,” and FMVSS No. 303, “Fuel system integrity of compressed natural gas vehicles,” only applies to light vehicles and to heavy school buses.

<sup>29</sup>The REESS is charged to 95 percent state-of-charge for REESS designed to be externally charged and charged to no less than 90 percent of state-of-charge for REESS designed to be charged only by an energy source on the vehicle.

have electric isolation of at least 100 ohms/volt or provide protection level IPXXB against direct contact of high voltage sources.<sup>30</sup>

Because there are no full vehicle crash tests currently in FMVSSs for heavy vehicles (other than heavy school buses), NHTSA seeks comment on a mechanical integrity test for REESS on heavy vehicles to evaluate post-crash safety at a component-level. As noted above, the current quasi-static loads of the integrity test specified in GTR No. 20 are specific to light vehicles. NHTSA seeks comment on the parameters for a possible quasi-static crush test for the REESS on heavy vehicles.<sup>31</sup> The agency requests feedback on the merits of the integrity test in assessing post-crash safety for heavy vehicle REESS. NHTSA seeks comment on the practicability of such a test and on the specifics of subsystem components that should be included with the REESS while conducting the crush test. NHTSA requests that commenters provide data to substantiate their assertions.

## **ii. Request for Comment; Mechanical Shock Test**

NHTSA seeks comment to inform our research on a mechanical shock test for REESS on heavy vehicles to evaluate post-crash safety at a component level. The aim of the mechanical shock requirement in GTR No. 20 is to verify the safety performance of the REESS under inertial loads which may occur during an impact. The requirement evaluates specifically the performance of the REESS mountings and fixtures to the vehicle.

The mechanical shock test is conducted with the REESS along with any subsystem components installed on a sled system using the mounting structures that are used for installing the REESS to the vehicle. The REESS is decelerated or accelerated with an acceleration profile within the acceleration corridor in Figure 1 and in accordance with acceleration magnitudes in

---

<sup>30</sup> IPXXB and IPXXD “protection levels” refer to the ability of the physical barriers to prevent entrance of a probe into the enclosure, to ensure no direct contact with high voltage sources. “IPXXB” is a probe representing a small human finger. “IPXXD” is a slender wire probe. Protection degrees IPXXD and IPXXB are International Electrotechnical Commission specifications for protection from direct contact of high voltage sources.

<sup>31</sup> NHTSA’s research evaluated the crush resistance of REESS using a displacement-based loading method. See Ford Safety Performance of Rechargeable Energy Storage Systems, Appendix A, DOT HS 812 756, July 2019. <https://rosap.nhtl.bts.gov/view/dot/41840>.

Table 1 through Table 3 for different vehicle GVWRs. The test concludes with an observation period of one hour at the ambient temperature conditions of the test environment.

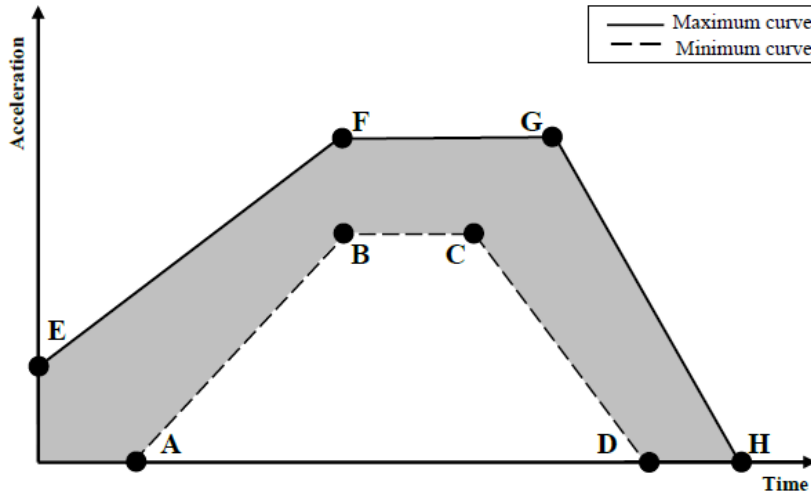

Figure 1– Generic Description of Test Pulses – Mechanical Shock Test

Table 1 – Mechanical Shock Test – Acceleration Values for Vehicles with a GVWR less than or equal to 3,500 kg (7,716 lbs)

Point	Time (ms)	Acceleration (g)	
		Longitudinal	Transverse
A	20	0	0
B	50	20	8
C	65	20	8
D	100	0	0
E	0	10	4.5
F	50	28	15

G	80	28	15
H	120	0	0

Table 2 – Mechanical Shock Test – Acceleration Values for Vehicles with a GVWR greater than 3,500 kg (7,716 lbs) and less than or equal to 12,000 kg (26,455 lbs)

<i>Point</i>	<i>Time (ms)</i>	<i>Acceleration (g)</i>	
		Longitudinal	Transverse
A	20	0	0
B	50	10	5
C	65	10	5
D	100	0	0
E	0	5	2.5
F	50	17	10
G	80	17	10
H	120	0	0

Table 3 – Mechanical Shock Test – Acceleration Values for Vehicles with a GVWR greater than 12,000 kg (26,455 lbs)

<i>Point</i>	<i>Time (ms)</i>	<i>Acceleration (g)</i>	
		Longitudinal	Transverse
A	20	0	0
B	50	6.6	5

C	65	6.6	5
D	100	0	0
E	0	4	2.5
F	50	12	10
G	80	12	10
H	120	0	0

---

During the mechanical shock test, the REESS is required to have no evidence of electrolyte leakage, fire, or explosion. The REESS is required to have electric isolation of at least 100 ohms/volt or have protection degree IPXXB.

Since there are no full vehicle crash tests currently in FMVSSs for heavy vehicles (other than heavy school buses) to evaluate post-crash safety at a system level, NHTSA seeks comment to inform possible future research on a mechanical shock test for REESS on heavy vehicles to evaluate post-crash safety at a component level. Among other matters, NHTSA requests comment on the following apparent limitations of the GTR test. The mechanical shock test in GTR No. 20 aims primarily at evaluating the safety performance of the REESS mounting fixture, which does not appear to address a safety need presently observed in the field.<sup>32</sup> Furthermore, the accelerations captured in the GTR No. 20 for the mechanical shock requirement may be too low, according to a technical study performed by the Transportation Research Laboratory.<sup>33</sup> The aim of the technical study was to review the appropriateness of the crash pulses used in current European regulations. This study determined that the crash pulse requirements in a number of

---

<sup>32</sup> Under the Vehicle Safety Act, the FMVSSs must, among other things, be practicable, meet the need for motor vehicle safety, and be stated in objective terms. (49 U.S.C. 30111(a).)

<sup>33</sup> European Commission, Directorate-General for Internal Market, Industry, Entrepreneurship and SMEs, Edwards, M., Hylands, N., Grubor, D., et al., *Technical study to review the appropriateness of crash pulses used in current EU legislation : final report*, Section 4.4, Publications Office, 2021, <https://data.europa.eu/doi/10.2873/58935>

the EU regulations (including R67, R100, and R110) are not representative of current vehicles. (These are among the reasons NHTSA is not proposing the mechanical shock test in GTR No. 20 for heavy vehicles in this NPRM.)

NHTSA seeks comment on the relevance of the mechanical shock test for heavy vehicles. NHTSA seeks comment on how the mechanical shock test would be performed on heavy vehicle REESSs, the appropriate accelerations levels that would be representative of acceleration levels observed in the field or in crash tests, and appropriate requirements which the REESS would need to meet in a mechanical shock test.

NHTSA seeks comment on the best approach or test method for evaluating post-crash safety for electric vehicles with a GVWR greater than 4,536 kg (10,000 lb). Specifically, NHTSA seeks comment and recommendations on other applicable safety tests and corresponding objective performance criteria to evaluate the propulsion system crash safety performance of vehicles with a GVWR greater than 4,536 kg (10,000 lb). NHTSA seeks comment on whether the moving contoured barrier crash test proposed for heavy school buses in the above section in this preamble can or should be applied to all heavy vehicles.

#### **b. General Specifications Relating to Crash Testing**

This NPRM proposes several general provisions from GTR No. 20 that would apply to various testing and performance requirements. NHTSA highlights the following proposals below. These provisions pertain to light vehicles and heavy school buses subject to the crash testing requirements of proposed FMVSS No. 305a.

##### **1. Low Energy Option for Capacitors**

Currently, FMVSS No. 305 S5.3 requires that vehicles meet one of the following three criteria post-crash: electrical isolation; absence of high voltage; or physical barrier protection. This NPRM proposes a low energy option for capacitors in the electric powertrain in FMVSS No. 305a.

Capacitors store electrical energy and may be connected directly to the chassis in some electric power trains. In fuel cell electric vehicles (FCEVs), the high-voltage systems may

contain capacitors that are connected to high voltage buses and are not electrically isolated. Such capacitors may be high voltage sources post-crash (because a charged capacitor may not discharge quickly) and may not be able to comply with post-crash electrical safety requirements using the direct and indirect contact protection option or the electrical isolation. However, capacitors may not pose a safety hazard when contacted, even though they may be high voltage sources post-crash, because they are low energy high voltage sources.

NHTSA has previously considered this issue. In a 2007 NPRM responding to petitions for rulemaking from what were then the Alliance of Automobile Manufacturers (Alliance) and the Association of International Automobile Manufacturers (AIAM),<sup>34</sup> NHTSA sought comments regarding a request of the petitioners to include 0.2 Joule (J) as an appropriate low energy threshold for electrical safety compliance post-crash for high voltage sources.<sup>35</sup> The petitioners believed that the low energy option was non-harmful, and argued in their subsequent comments to the NPRM<sup>36</sup> that the option is necessary due to the presence of x- and y-capacitors in the powertrain of fuel cell vehicles. After evaluating the comments, NHTSA ultimately disagreed with the petitioners and decided against a low energy option for post-crash electrical safety because the agency was not convinced that a low energy option was needed and had concerns about the possible disparity between the level of safety provided by 0.2 J of energy and the electrical isolation requirement.<sup>37</sup> At that time a safety need for a low energy option was not yet clear and the agency expressed concerns regarding the practicality of measuring the residual energy in a crash test environment.

NHTSA is reconsidering this issue in this NPRM. GTR No. 20 contains a detailed analysis of the 0.2 Joules energy limit for the low energy post-crash electrical safety compliance option. While the 2007 NPRM considered a low energy post-crash electrical safety compliance

---

<sup>34</sup> In January 2020, the two industry associations merged to form the Alliance for Automotive Innovation (generally referred to as the Auto Innovators).

<sup>35</sup> 72 FR 57260, October 9, 2007.

<sup>36</sup> NHTSA-2007-28517-0004

<sup>37</sup> Final rule, 75 FR 33515, 33519; June 14, 2010.

option for any high voltage source in the powertrain, GTR No. 20 only provides this option to capacitors in the powertrain.

NHTSA conducted an analysis using human body resistance charts, long and short duration capacitance discharge pulse profiles, and the graphs of physiological effects of AC and DC body current by duration of exposure from two International Electrotechnical Commission (IEC) technical publications,<sup>38</sup> to determine safe energy levels for the human body. NHTSA has submitted a technical memorandum to the docket for this NPRM that provides details and results of the agency's analysis.

Based on the analysis results, NHTSA tentatively concludes that a post-crash electrical safety compliance option for capacitors based on an electrical energy of 0.2 Joules or less provides adequate safety from electrical shock and long-term harmful effects on the human body. Providing this post-crash compliance option would allow for practicable powertrain designs for battery electric and fuel cell vehicles without any reduction in safety. Automotive high-voltage systems typically utilize a number of capacitors connected to high voltage buses, and it is not always practical to discharge every capacitor post-crash. NHTSA tentatively believes that by providing this compliance option for a safe energy limit, vehicle manufacturers would have the flexibility to design products that assure safety. NHTSA seeks comments on the parameters (human body resistance, discharge profiles) used in the analysis and the analysis method.

## **2. Assessing Fire or Explosion in Vehicle Post-Crash Test**

After a real-world crash, passengers within the vehicle need time to safely egress from the vehicle or be rescued by first responders. During this time, passengers should not be exposed to hazards such as fire or explosion of the REESS, which may hinder their egress or rescue.

---

<sup>38</sup> IEC 60479-1 and 60479-2 Effects of Current on Human Beings and Livestock—Part 1: General Aspects, Part 2: Special Aspects, 2005-07, Reference Nos. CEI/IEC/TS 60479-1:2018 and CEI/IEC/TS 60479-2:2019. <https://webstore.iec.ch/publication/62980>; <https://webstore.iec.ch/publication/63392> (last accessed September 26, 2023).

GTR No. 20 requires that for a period of one hour after a crash test, there shall be no evidence of fire or explosion of the REESS. However, such a requirement is not currently in FMVSS No. 305. In accordance with GTR No. 20, NHTSA proposes to include in FMVSS No. 305a a requirement that there be no evidence of fire or explosion for the duration of one hour after the crash test for heavy school buses, and for the duration of one hour after each crash test and subsequent quasi-static rollover test for light vehicles. The assessment of fire or explosion would be verified by inspection without removal of the REESS or any parts of the vehicle.

### **3. Assessing Post-Crash Voltage Measurements**

This NPRM proposes to clear up a source of ambiguity in FMVSS No. 305. FMVSS No. 305 requires that the post-crash voltage measurements be made at least 5 seconds after the vehicle comes to rest. However, at times it is not entirely clear when the vehicle comes to rest because there is always some vibration and slight vehicle motion post-crash. For consistency with the GTR No. 20 test procedure, NHTSA proposes that the voltage measurements in FMVSS No. 305a would be made between 10 seconds and 60 seconds after the impact. The agency tentatively believes that 10 seconds after impact is sufficient time for voltage measurement and 60 seconds after impact is early enough that any high voltage arcing would be detected. NHTSA seeks comment on this approach.

### **4. Electrolyte Spillage Versus Leakage**

Currently, FMVSS No. 305 S5.1 addresses “electrolyte spillage from propulsion batteries.” The standard specifies that following a crash test, not more than 5.0 liters of electrolyte from propulsion batteries shall spill outside the passenger compartment, and that no visible trace of electrolyte shall spill into the passenger compartment. NHTSA proposes to use terms related to “leakage” instead of spillage. When the electrolyte spillage<sup>39</sup> requirement was originally adopted in 2000, EV propulsion batteries were envisioned to be a series of lead-acid

---

<sup>39</sup> Per Section B, “S5.1 Electrolyte Spillage from Propulsion Batteries,” NHTSA stated in 65 FR 57980 that “leakage” is synonymous for “spillage.” Both words indicate the escape of electrolyte from the battery.

batteries. Lead-acid batteries at the time had large quantities of liquid electrolyte that could spill out of the battery if the battery structure were compromised in a crash. At that time, it was appropriate to eliminate the term “leakage” due to its synonymy to “spillage,” to avoid questions of whether different meanings were intended by the different words.

Current EV propulsion batteries, however, are lithium-ion batteries. The cells of lithium-ion batteries have small quantity of electrolyte that could leak out of the battery casing rather than spill. Thus, NHTSA proposes to use the term “electrolyte leakage,” which is more relevant than “electrolyte spillage” for these batteries.

NHTSA seeks comment on the inclusion of a post-crash electrolyte leakage requirement in FMVSS No. 305a and the necessity and relevance of such a requirement for current EVs. Specifically, NHTSA seeks comment on whether this requirement is still relevant given today’s propulsion battery technologies and if it is still necessary based on the safety incidents observed in the field or in crash tests. NHTSA seeks comment on whether a 5-liter maximum amount of electrolyte permitted to be leaked is still relevant and requests commenters to provide data based on safety incidents observed in the field or in crash tests to substantiate their assertions.<sup>40</sup> NHTSA seeks comment on and recommendations regarding electrolyte leakage detection methods and how these detection methods can discern between the presence of electrolyte and the presence of other liquids such as coolant.

### **c. REESS Requirements Applicable to All Vehicles**

This section of the NPRM addresses REESS safety performance requirements during normal vehicle operation. The REESS requirements would apply to all vehicles subject to FMVSS No. 305a.

#### **Introduction**

---

<sup>40</sup> GTR No. 20 requires that the electrolyte leaking from the REESS during and after the crash test is no more than 7 percent by volume of the REESS electrolyte. However, there is no practical way of measuring the quantity by volume of the electrolyte in the REESS.

Currently, FMVSS No. 305 does not have any requirements for the safe operation of the REESS and for mitigating risks of fire and other safety risks associated with it. This NPRM's proposed requirements would protect the REESS against external fault inputs, ensure the REESS operations are within the manufacturer-specified functional range, provide protection from thermal propagation in the event of single-cell thermal runaway (SCTR) due to an internal short-circuit, provide a warning if there is a thermal event within the REESS or a malfunction of vehicle controls that manage REESS safe operation, and ensure safe REESS operation during and after water exposure.

While REESS is a general term to represent any rechargeable electrical energy storage system, currently all electric powered vehicles use REESS with lithium-ion chemistry. Therefore, the current safety hazards associated with REESS identified in literature and in the field are those specific to lithium-ion chemistry REESS. However, the proposed requirements in this NPRM will apply regardless of REESS chemistry.

REESSs are designed and manufactured to operate safely within a range of operating parameters, including temperature ranges, charge levels, and current levels. If the REESS is subjected to fault conditions outside these operating ranges such as overcharge, over-discharge, overcurrent, over-temperature, external short-circuit, or low temperature, these conditions can result in damage to the cells. Cell damage increases the risk of hazardous conditions such as electrolyte leakage, reduced electrical isolation, and fire in the REESS (thermal runaway). Manufacturers include controls in electric vehicles to manage REESS operation to ensure they stay within the specified safe operating range, thereby mitigating damage to the REESS. The system that monitors and controls the REESS is referred to as the battery management system (BMS). NHTSA proposes requirements to assure that the BMS has controls that protect the REESS against these faults by, e.g., stopping the vehicle from charging to prevent overcharge.

### **Performance Criteria For Normal Vehicle Operations – General**

The performance criteria specified in GTR No. 20 for each of the vehicle control performance tests specify no evidence of electrolyte leakage, rupture (applicable to high voltage REESSs only), venting (applicable to REESSs other than open-type traction batteries<sup>41</sup>), fire, or explosion. For high voltage REESSs, the electrical isolation is required to be greater than or equal to 100 ohms per volt, for a DC high voltage source. This NPRM proposes the same performance criteria to protect the REESS against external faults, such as a fault in an external charger that could result in the charger supplying greater current than requested by the vehicle and/or charging the REESS beyond full state of charge.<sup>42</sup>

Under proposed FMVSS No. 305a, the evidence of electrolyte leakage, venting,<sup>43</sup> or rupture is verified by visual inspection without disassembly of any part of the vehicle. Visible smoke during and after the test, and/or the presence of soot and/or electrolyte residue in post-test visual inspection are indicators of venting and electrolyte leakage. The overcharge, over-discharge, overcurrent, over-temperature, and external short-circuit test procedures specify that the agency would perform a standard cycle after completing exposure to each of the external faults, provided that the vehicle permits charging and discharging at that time. A standard cycle, as specified in GTR No. 20 and proposed FMVSS No. 305a, consists of a standard discharge and followed by a standard charge. If the vehicle is operable after exposure to the external fault, running the standard cycle after exposure to the external fault condition – while observing the vehicle for one hour for evidence of electrolyte leakage, rupture, venting, fire, or explosion, followed by voltage measurements for determining electrical isolation – would ensure that continuing operating the vehicle would not result in safety hazards.

---

<sup>41</sup> Open-type traction batteries are a type of battery which are filled with liquid and generate hydrogen gas that is released into the atmosphere.

<sup>42</sup> The control pilot pin of the charger communicates with the vehicle during charging. Based on the state of charge (SOC), the vehicle requests a certain level of current and the vehicle charger provides that level. Other external faults could arise when attempting to drive the vehicle beyond the lowest safe operating SOC of the REESS (over-discharge of the REESS), driving fast up a steep hill for a long period of time that could cause the REESS to heat beyond its highest safe operating temperature, and charging a REESS at very cold temperatures that could cause lithium plating.

<sup>43</sup> NHTSA elaborates on the proposed venting requirement at the end of this section.

The vehicle might not permit charging and discharging after detecting a dangerous condition; NHTSA considers this a safety feature and that such a test outcome would not amount to an apparent noncompliance. The inability to perform a standard cycle after exposure to the external fault does not terminate the test. If the vehicle does not permit charging and discharging after exposure to an external fault, then the standard cycle is simply not performed and the test proceeds. Specifically, the test ends with the vehicle observed for one hour for evidence of electrolyte leakage, rupture, venting, fire, or explosion, followed by voltage measurements for determining electrical isolation.

The standard cycle would be conducted with the breakout harness connected to the manufacturer-specified location(s) on the traction side of the REESS<sup>44</sup> on the vehicle's electric power train. The REESS is charged and discharged using a high voltage battery tester/cycler (with appropriate power and voltage ranges) which is connected to the vehicle through the breakout harness, as shown in Figure 2 below (for illustration purposes only).

---

<sup>44</sup> The manufacturer is required by proposed FMVSS No. 305a to specify the location for connecting the breakout harness and may also provide appropriate breakout harnesses for testing the vehicle. If the manufacturer does not provide a breakout harness, NHTSA would use a generic breakout harness to connect to the traction side of the REESS.

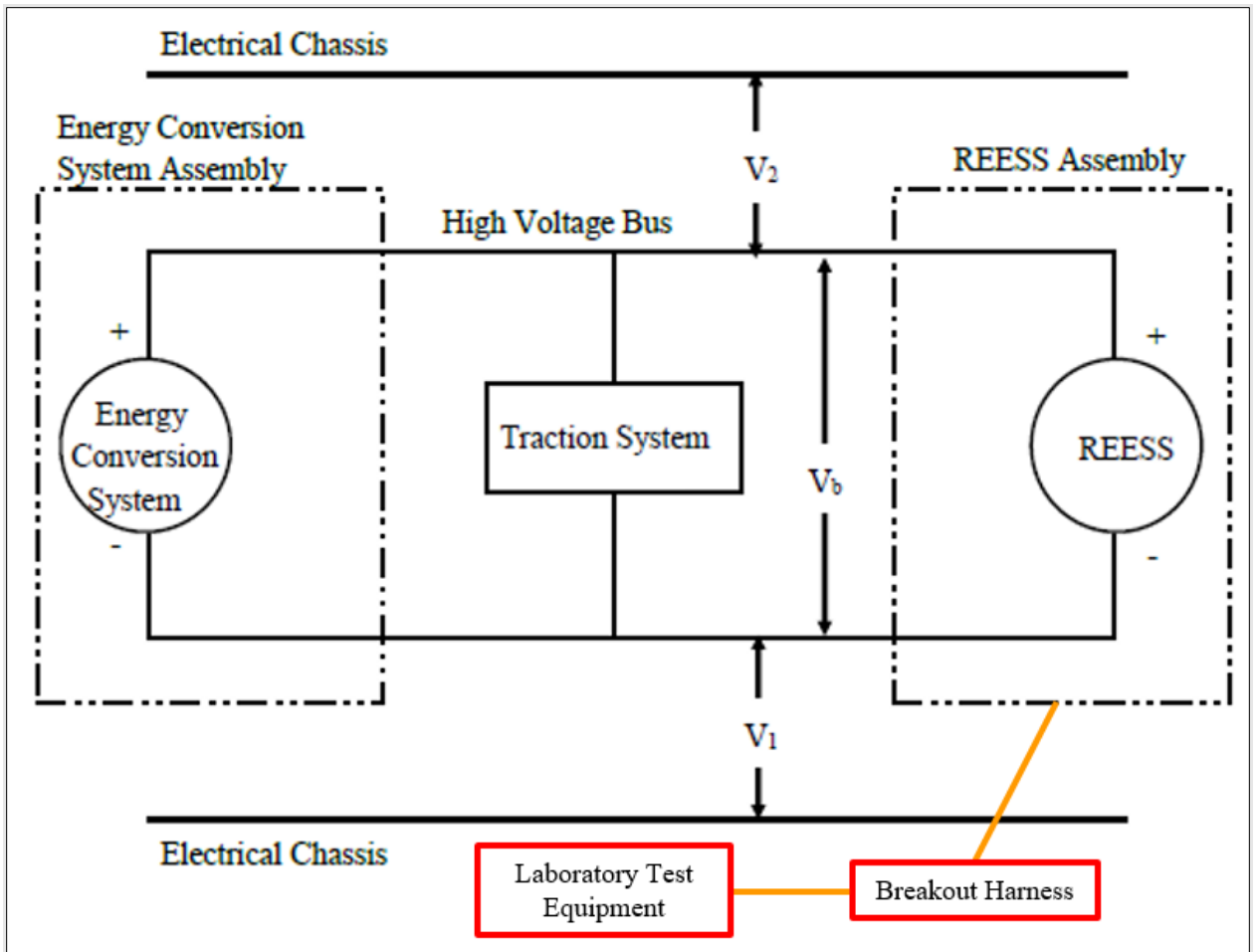

Figure 2 – Connection of the Breakout Harness & Laboratory Test Equipment to the Vehicle

NHTSA proposes that the discharge and charge rates for the standard cycle would be provided by the vehicle manufacturer. NHTSA proposes that, if the discharge rate is not specified by the manufacturer, NHTSA would use a discharge rate (C-Rate) of 1C current. A “nC Rate” is the magnitude of constant current that would charge or discharge the REESS in 1/n hour between 0 percent state of charge (SOC) and 100 percent SOC. Discharge would continue until automatically terminated by vehicle controls at the manufacturer-specified minimum operating SOC of the REESS. After discharge, the standard cycle would include a 15-minute rest period before the charging procedure commences. If a charge procedure is not specified, then a charge rate (i.e., C-Rate) of  $\frac{1}{3}C$  current would be used. Charging is continued until automatically terminated by vehicle controls at the manufacturer-specified maximum operating SOC of the REESS.

## **REESS Venting**

Venting is the release of excessive internal pressure from a cell or REESS in a manner intended by design to preclude rupture or explosion. Venting during normal vehicle use may be associated with (a) combustion and/or decomposition of electrolyte, or (b) vaporization of the electrolyte. In case of condition (a), the emissions from the cells may increase the risk to vehicle occupants if they are exposed to such substances. In case of condition (b), the amount of the gases released is considered less likely to pose a safety risk to the occupants. Venting in the case of condition (a) may result in the release of gases and particulates from the REESS, thereby potentially exposing vehicle occupants to the emissions (gases and particulate matter).<sup>45</sup> Hazards associated with toxicity, corrosiveness, and flammability of the gases emitted from the REESS and associated human health exposure limits vary considerably. As noted above, NHTSA proposes to include a provision in FMVSS No. 305a to limit the safety risks to vehicle occupants due to venting during normal vehicle operations. The provision is based on GTR No. 20 requirements described below.

GTR No. 20 specifies that under normal vehicle operation, the vehicle occupants are not exposed to any hazardous environment caused by venting from the REESS. To avoid human harm that may occur due to potential toxic or corrosive emissions, GTR No. 20 specifies that there be no venting from the REESS for the following normal vehicle operations tests: vibration, thermal shock and cycling, external short circuit protection, overcharge protection, over-discharge protection, over-temperature protection and overcurrent protection. GTR No. 20 includes a no-fire requirement in these tests which addresses the issue of vented gas flammability. During the development of GTR No. 20, a robust and repeatable method to verify the occurrence of venting and the potential exposure of vehicle occupants to various gases from the venting was sought, but no suitable method was found. Visual inspection was found to be the

---

<sup>45</sup> Gases generated in and vented from lithium-ion (Li-ion) batteries typically include carbon dioxide (CO<sub>2</sub>), carbon monoxide (CO), hydrogen (H<sub>2</sub>), oxygen (O<sub>2</sub>), light C<sub>1</sub>-C<sub>5</sub> hydrocarbons, e.g., methane and ethane, and fluorine-containing compounds such as hydrogen fluoride (HF) and fluoro-organics, e.g., ethyl-fluoride.

best approach at this time for verifying the occurrence of venting for assessing the influence of vented gases on vehicle occupants. Therefore, GTR No. 20 specifies that evidence of venting in these tests is verified by visual inspection (evidence of soot, electrolyte residues) without disassembling any part of the REESS.

NHTSA proposes to use a similar approach in FMVSS No. 305a to evaluate the safety risks to vehicle occupants resulting from venting from the REESS. The agency acknowledges that research is needed to develop a repeatable, reproducible, and practical method to verify the occurrence of various vented gases and the potential exposure and harm to vehicle occupants. However, NHTSA tentatively concludes that in the absence of such a method, the requirement that there must be no fire, electrolyte leakage or venting during the tests evaluating vehicle controls for safe REESS operation (external short-circuit protection, overcharge protection, over-discharge protection, over-temperature, and overcurrent protection) would reduce some safety risks to vehicle occupants due to venting from the REESS. The evidence of venting in these tests would be verified by visual inspection (evidence of soot, electrolyte residues) without disassembling any part of the REESS.

NHTSA also requests comment in an Appendix to this preamble on the IWG's continuing work on venting in Phase 2 of the GTR.

### **1. Vehicle Controls for Safe REESS Operation**

This NPRM proposes the following performance requirements and associated test procedures for vehicles to ensure they have controls managing safe REESS operations. There are some minor differences between the GTR No. 20 test procedures and those proposed in this NPRM that are based on the lessons learned from NHTSA's test program. Those differences pertain to the ease of conducting the test.<sup>46</sup>

---

<sup>46</sup> For example, the state of charge of the REESS at the beginning of the test differed in some instances from that in GTR No. 20 to enable completing the test more readily.

NHTSA funded research to validate a collection of test procedures that assess safety hazards to electric vehicles while being charged or when the REESS exceeds its recommended operational limits.<sup>47,48</sup> The research independently evaluated, refined, and validated vehicle-level test procedures that could be robustly applied to a wide range of vehicle technologies and battery configurations. Based on the results of NHTSA's research, the agency proposes to conduct full vehicle-level tests using a breakout harness connected to a battery tester/cycler<sup>49</sup> to evaluate vehicle controls for safe REESS operation, rather than conducting the tests on the REESS as a separate component. NHTSA is proposing vehicle-level testing because evaluating REESS safe operation at the vehicle level would evaluate the entire vehicle system and the associated vehicle controls, whereas conducting the tests at the equipment level would not evaluate all the relevant vehicle controls or any interaction or interference between vehicle controls.

NHTSA evaluated the GTR No. 20 test procedures for feasibility, practicability, and objectivity by conducting the test procedures on a 2019 Chevy Bolt, 2020 Tesla Model 3, and 2020 Nissan Leaf S Plus.<sup>50, 51, 52</sup> NHTSA's test program demonstrated the ease of conducting tests at a vehicle level using breakout harnesses connected to a battery cycler/tester for the external inputs to the REESS without having to remove the REESS from the vehicle to conduct component level tests. The proposed test procedures for overcharge, over-discharge, overcurrent, over-temperature, and external short-circuit tests are non-destructive tests intended to evaluate vehicle controls to protect the REESS and can be conducted in serial order on the same vehicle.

---

<sup>47</sup> DC Charging Safety Evaluation Procedure Development, Validation, And Assessment, and Preliminary AC Charging Evaluation Procedure - DOT HS 812 754 and DOT HS 812 778 - July 2019. <https://rosap.nhtsa.gov/view/dot/41933>

<sup>48</sup> System-Level RESS Safety and Protection Test Procedure Development, Validation, and Assessment—Final Report - DOT HS 812 782 October 2019 <https://rosap.nhtsa.gov/view/dot/42551>

<sup>49</sup> A battery tester/cycler is equipment that can be used for charging and discharging REESS and for conducting specialized tests on the REESS. An example of a battery tester with hybrid and battery electric vehicles is the NHR 9300 battery test system (NHR 9300).

<sup>50</sup> NHTSA Test Report on the 2020 Tesla Model 3 Standard Range 4-Door Sedan can be accessed here: [https://downloads.regulations.gov/NHTSA-2021-0029-0003/attachment\\_2.pdf](https://downloads.regulations.gov/NHTSA-2021-0029-0003/attachment_2.pdf)

<sup>51</sup> NHTSA Test Report on the 2020 Nissan Leaf S Plus (62kWh Battery) 5-Door Hatchback can be accessed here: [https://downloads.regulations.gov/NHTSA-2021-0029-0002/attachment\\_2.pdf](https://downloads.regulations.gov/NHTSA-2021-0029-0002/attachment_2.pdf)

<sup>52</sup> NHTSA Test Report on the 2019 Chevy Bolt can be accessed here: [https://downloads.regulations.gov/NHTSA-2021-0029-0001/attachment\\_2.pdf](https://downloads.regulations.gov/NHTSA-2021-0029-0001/attachment_2.pdf)

### **i. Overcharge Protection**

A battery pack experiences an overcharge when a charger forces its state of charge (SOC) level to rise above 100 percent. Overcharge of a REESS can occur because of a failure of the charging system, such as a fault in an external charger, a fault in the vehicle's regenerative braking system, a sensor failure, or a voltage reference drift.<sup>53</sup> Overcharge can lead to swelling of an electrochemical cell, lithium plating, stability degradation, or over-heating, and ultimately can lead to thermal runaway.<sup>54</sup> Severe events such as fire or explosion may occur. Therefore, vehicle controls to ensure the REESS does not get overcharged are important for long-term safe operation of the REESS.

Vehicle level controls or the BMS typically prevent charging when the manufacturer-specified maximum operating SOC of the REESS is achieved. GTR No. 20 includes a test to evaluate the performance of vehicle controls to prevent overcharge of the REESS. NHTSA tentatively concludes that GTR No. 20's overcharge test is practical and feasible based on the agency's own testing.<sup>55</sup> NHTSA proposes to include the overcharge protection requirement and test procedure in FMVSS No. 305a.

The proposed overcharge test would be performed on a complete vehicle as follows. The test is conducted with the REESS initially set at 90 to 95 percent SOC<sup>56</sup> and at ambient temperatures between 10 °C and 30 °C. The breakout harness is attached on the traction side of the REESS at the vehicle manufacturer's recommended location(s) and attachment point(s), and the battery tester/cycler is connected to the breakout harnesses to supply the charge current. Temperature probes are connected to the REESS case to monitor changes in the REESS

---

<sup>53</sup> Voltage can drift based on temperature. Higher temperature can result in lower voltage.

<sup>54</sup> Thermal runaway of a lithium-ion cell in a REESS occurs when the thermal stability limit of the cell chemistry is exceeded, and the cell releases its energy via an exothermic reaction at an uncontrolled rate such that the heat generated is faster than that dissipated.

<sup>55</sup> See Test reports in docket no. NHTSA-2021-0029, available at [www.regulations.gov](http://www.regulations.gov). Detailed test procedures are provided in the test reports of the 2021 Chevrolet Bolt (NHTSA-2021-0029-0001), 2020 Nissan Leaf (NHTSA-2021-0029-0002), and the 2020 Tesla Model 3 (NHTSA-2021-0029-0003).

<sup>56</sup> Ranges in temperature and SOC are provided for this and other test procedures for practicability and ease of conducting the tests. In the overcharge test, the REESS is initially set at a high SOC (90 to 95 percent) to enable fully charging the REESS in a shorter period of time.

temperature. Temperature measurements may also be obtained through communication with the REESS control module.<sup>57</sup>

The vehicle is turned on and the REESS is charged using the battery tester/cycler in accordance with the manufacturer's recommended maximum charge current <sup>58</sup> until one of the following has occurred:

- (a) the REESS overcharge protection control terminates the charge current;
- (b) the REESS temperature is 10 °C above its maximum operating temperature specified by the manufacturer;<sup>59</sup> or,
- (c) 12 hours have passed since the start of charging the vehicle.

After the overcharge condition is terminated, a standard cycle is performed if possible. The test concludes with a 1-hour observation period in which the vehicle is observed for any evidence of electrolyte leakage, rupture, venting, fire, or explosion. At the conclusion of the post-test observation period, the electrical isolation is determined in the same manner as currently in FMVSS No. 305 S7.6 using a voltmeter to measure voltages.

## **ii. Over-discharge Protection**

Over-discharging a REESS, which means discharging it below its lowest state of charge specified by the manufacturer, can lead to undesirable aging, electrolyte leakage, swelling, solid electrolyte interphase (SEI) decomposition, internal short-circuit, and damaged cell stability and safety on subsequent recharges. Even though the initial over-discharge response of lithium-ion cells generally appears benign, it can cause damage to cell electrodes that can compromise cell stability and safety on subsequent recharge. Subsequent charging of an over-discharged REESS may lead to fire or explosion.

---

<sup>57</sup> Commercial diagnostic tools or tools supplied by the manufacturer may be used to read the Temperature measurements within the REESS from the vehicle's Controller Area Network (CAN bus).

<sup>58</sup> If the manufacturer does not provide an appropriate charge current, then a charge rate (i.e., C-Rate) of C/3 current would be used.

<sup>59</sup> The manufacturer would specify the procedure for monitoring the temperature of the REESS during testing. This could be measured by attaching thermocouples to the casing of the REESS or obtained from the CAN bus using appropriate tools.

Vehicle controls or the BMS typically prevent over-discharging when the manufacturer specified minimum operating SOC of the REESS is achieved. GTR No. 20 includes a test to evaluate the performance of vehicle controls to prevent over-discharge of the REESS. NHTSA tentatively concludes that GTR No. 20's over-discharge test is practical and feasible based on the agency's own testing.<sup>60</sup> NHTSA proposes to include the over-discharge protection requirement and test procedure in FMVSS No. 305a.

The over-discharge test is performed at ambient temperatures between 10 °C and 30 °C on a complete vehicle. The SOC of the REESS at the beginning of the test is set at 10 to 15 percent.<sup>61</sup> For a vehicle with on-board energy conversion systems (e.g., internal combustion engine, fuel cell, etc.), the fuel supply is set to the minimum level<sup>62</sup> where active driving mode is permitted. Similar to the overcharge test, the breakout harness is attached on the traction side of the REESS at the vehicle manufacturer's recommended location(s) and attachment point(s), and the battery tester/cycler is connected to the breakout harness to discharge the REESS.<sup>63</sup> Temperature probes are connected to the REESS case to monitor changes in the REESS temperature. Temperature measurements may also be obtained through communication with the REESS control module.

The vehicle is turned on and the REESS is discharged using the battery tester/cycler in accordance with the manufacturer's recommended discharging rate<sup>64</sup> under normal operating conditions until one of the following has occurred:

- (a) vehicle controls terminate the discharge current,

---

<sup>60</sup> See Test reports in Docket No. NHTSA-2021-0029, available at [www.regulations.gov](http://www.regulations.gov). Detailed test procedures are provided in the test reports of the 2021 Chevrolet Bolt (NHTSA-2021-0029-0001), 2020 Nissan Leaf (NHTSA-2021-0029-0002), and the 2020 Tesla Model 3 (NHTSA-2021-0029-0003).

<sup>61</sup> Ranges in temperature and SOC are provided for this and other test procedures for practicability and ease of conducting the tests. In this case, the test is initiated with the REESS at a low SOC (10 to 15 percent) to enable discharging the REESS in a shorter period of time.

<sup>62</sup> Minimum level of fuel supply needed would be provided by the manufacturer.

<sup>63</sup> A discharge resistor may also be used for this purpose.

<sup>64</sup> If the manufacturer does not specify a discharge rate, a power load of 1kW is used.

(b) the temperature gradient of the REESS is less than 4 °C<sup>65</sup> through two hours, or

(c) if the vehicle is discharged to 25 percent of its nominal voltage level.

At the conclusion of the discharge termination, one standard charge is performed, followed by one standard discharge. The test concludes with a 1-hour observation period in which the vehicle is observed for any evidence of electrolyte leakage, rupture, venting, fire, or explosion. At the conclusion of the observation period, the electrical isolation is determined in a similar manner as that in current FMVSS No. 305 S7.6 using a voltmeter to measure voltages.

### **iii. Overcurrent Protection**

As noted earlier, the vehicle and the charging system communicate the level of current needed to charge the REESS. If there is a problem in the communication or if the charging system malfunctions, higher current may be provided though not requested by the vehicle. During direct current (DC) fast-charging, failure of the external charge equipment could cause over-current conditions in which the REESS receives higher current than it was designed to manage at a given state of charge of the REESS. Overcurrent conditions could result in heating of the REESS, electrochemical damage to the cells, and a risk of thermal runaway.

GTR No. 20 includes a test to evaluate the performance of vehicle controls to protect the REESS from overcurrent conditions. NHTSA tentatively concludes that GTR No. 20's overcurrent test is practical and feasible based on the agency's own testing.<sup>66</sup> NHTSA proposes to include the overcurrent protection requirement in FMVSS No. 305a. In accordance with GTR No. 20, NHTSA proposes to apply the overcurrent test to vehicles that have capability of charging by DC external electricity supply. The test is unnecessary for vehicles that only charge by alternating current (AC) supply because AC charging is slower and the inverters for AC

---

<sup>65</sup> Temperature variation of 4 °C indicates stable operation of the REESS. As noted earlier, the manufacturer specifies the procedure for monitoring the temperature of the REESS during testing. This could be measured by attaching thermocouples to the casing of the REESS or obtained from the CAN bus using appropriate tools.

<sup>66</sup> See Test reports in docket no. NHTSA-2021-0029, available at [www.regulations.gov](http://www.regulations.gov). Detailed test procedures are provided in the test reports of the 2021 Chevrolet Bolt (NHTSA-2021-0029-0001), 2020 Nissan Leaf (NHTSA-2021-0029-0002), and the 2020 Tesla Model 3 (NHTSA-2021-0029-0003).

charging manage any overcurrent. Also, overcurrent issues have not been observed in AC charging.

The overcurrent test is performed with a complete vehicle. To avoid the overcharge protection terminating the over-current condition, the SOC of the REESS is set between 40 to 50 percent. The test is conducted at ambient temperatures between 10 °C and 30 °C. The breakout harness is attached on the traction side of the REESS at the vehicle manufacturer's recommended location(s) and attachment point(s), and the battery tester/cycler is connected to the breakout harnesses to supply the charge current. Temperature probes are connected to the REESS case to monitor changes in the REESS temperature. Temperature measurements may also be obtained through communication with the REESS control module. The vehicle manufacturer specifies the highest normal charge current and the over-current level that is applied. The battery tester/cycler is programmed to supply an over-current during charging at the level specified by the manufacturer.

The vehicle is turned on and the REESS is charged using the battery tester/cycler in accordance with manufacturer's recommended charging procedure with the highest normal charge current specified by the manufacturer.<sup>67</sup> After charging is initiated, an over-current specified by the manufacturer<sup>68</sup> is supplied above that requested by the vehicle. The charge current is increased over the course of 5 seconds from the highest normal charge current to the over-current level. The charge current and the overcurrent supply is continued until one of the following has occurred: (a) vehicle over-current protection controls terminate the charging, or (b) the temperature gradient of the REESS is less than or equal to 4 °C for a two-hour period.

If possible, a standard cycle is performed using the connected breakout harness and battery cycler. The test concludes with an observation period of one hour in which the vehicle is

---

<sup>67</sup>The manufacturer supplied information define the constant current level and/or constant voltage level combination to charge the REESS. If a charge procedure is not specified, then a charge rate (i.e., C-Rate) of C/3 current is used.

<sup>68</sup> If the vehicle manufacturer does not supply an appropriate over-current level, the battery test/cycler will be programmed to initially apply a 10 Ampere over-current. If charging is not terminated, the over-current level of 20 amps will be applied. Subsequently, the over-current supply is increased in steps of 10 amperes.

observed for electrolyte leakage, rupture, venting, fire, or explosion. At the conclusion of the observation period, the electrical isolation is determined in a similar manner as that in current FMVSS No. 305 S7.6, using a voltmeter to measure voltages.

#### **iv. Over-temperature Protection**

While the impacts of over-temperature operation vary by chemistry, most battery chemistries can be negatively affected if operation by the driver is attempted at high temperatures (per the limits of a specific chemistry) or if aggressive operation is attempted at high temperatures (high-rate charging or discharging). A temperature imbalance or continued operation at elevated temperatures may even lead to thermal runaway of cells if appropriate countermeasures, such as de-rating,<sup>69</sup> are not taken.

Vehicle controls such as thermal management systems or the BMS continuously monitor temperature conditions to prevent REESS operation at elevated temperatures above the upper temperature boundary for safe REESS operations. GTR No. 20 includes a test to evaluate the performance of vehicle controls to prevent REESS temperatures exceeding the upper temperature boundary for safe REESS operations. NHTSA tentatively concludes that GTR No. 20's over-temperature test is practical and feasible based on the agency's own testing.<sup>70</sup> NHTSA proposes to include the over-temperature protection requirement and test procedure in FMVSS No. 305a, which aligns with GTR No. 20.

In the proposed FMVSS No. 305a, the over-temperature test is performed on a chassis dynamometer<sup>71</sup> with a complete vehicle. The SOC of the REESS at the beginning of the test is set between 90 to 95 percent. The test is conducted at ambient temperatures between 10 °C and

---

<sup>69</sup> De-rating is the reduction of a battery's available power and is typically due to a state that indicates an undesirable condition such as rapidly increasing cell temperature, elevated temperatures, or very cold cell temperatures. By temporarily reducing a battery's ability to provide and/or absorb power, de-rating allows the battery to cool down (or at least stop increasing in temperature) in situations with elevated temperatures and reduces operation when the battery is so cold that certain usage levels could cause damage.

<sup>70</sup> See Test reports in Docket No. NHTSA-2021-0029, available at [www.regulations.gov](http://www.regulations.gov). Detailed test procedures are provided in the test reports of the 2021 Chevrolet Bolt (NHTSA-2021-0029-0001), 2020 Nissan Leaf (NHTSA-2021-0029-0002), and the 2020 Tesla Model 3 (NHTSA-2021-0029-0003).

<sup>71</sup> A chassis dynamometer is a mechanical device that uses one or more fixed roller assemblies to simulate different road conditions within a controlled environment and is used for a wide variety of vehicle testing.

30 °C. For vehicles with on-board energy conversion systems (e.g., internal combustion engine, fuel cell, etc.), the fuel system must have sufficient supply to allow operation of the energy conversion system for about one hour of driving. The cooling system for the REESS is disabled (or significantly reduced for a REESS that will not operate with the cooling system disabled) per manufacturer-supplied information.<sup>72</sup> For REESSs that will not operate if the cooling system is disabled, the maximum amount of coolant is removed to minimize the cooling system's operation for the test.

Temperature probes are connected to the REESS case to monitor changes in the REESS temperature. Temperature measurements may also be obtained through communication with the REESS control module.

GTR No. 20 specifies that the vehicle be soaked for at least 6 hours in a thermally controlled chamber at 45 °C. However, NHTSA's testing<sup>73</sup> demonstrated that the presoaking of the vehicle at elevated temperatures does not raise the temperature of the REESS as significantly as by driving the vehicle under high acceleration and deceleration drive modes. Therefore, to reduce the test time and test burden, the agency does not believe it needs to specify presoaking of the vehicle.

The vehicle is installed on the chassis dynamometer and is placed into driving mode. The vehicle is driven on the dynamometer using the vehicle manufacturer-recommended appropriate drive profile for discharge and charge of the REESS that would raise the temperature of the REESS (with cooling system disabled or reduced function) above its safe operating temperature within one hour. If the vehicle manufacturer does not supply an appropriate drive profile, NHTSA will drive the vehicle over back-to-back aggressive acceleration (near 100% pedal application) and decelerations (near or above regenerative braking limits) such as the one shown

---

<sup>72</sup> Methods for disabling the cooling system may include crimping the liquid cooling hose or in the case of a refrigerant cooled package, removing the refrigerant fluid. For REESS cooled by cabin air, block the cabin air intakes used to provide cooling air flow to the REESS.

<sup>73</sup> System-Level RESS Safety and Protection Test Procedure Development, Validation, and Assessment—Final Report. DOT HS 812 782 October 2019. <https://rosap.ntl.bts.gov/view/dot/42551>

in Figure 3 below, where the vehicle is accelerated to 80 mph and then decelerated to 15 mph within 40 seconds.

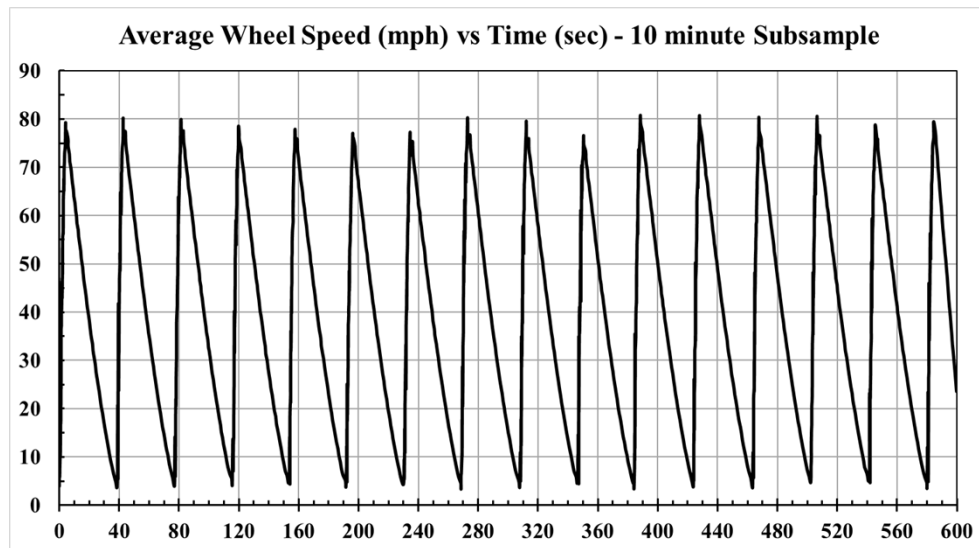

Figure 3 - Drive profile on dynamometer to quickly raise the temperature of the REESS. (For illustration purposes only)

Vehicle battery designs and controls mitigate overheating of the REESS in different ways: (1) Terminate discharge/charge operations when the REESS temperature reaches its operating bounds; (2) Derate (reduce acceleration/speed of the vehicle) to prevent the REESS reaching its maximum operating temperature; (3) REESS cell chemistries are stable at higher REESS temperature. In order to accommodate different approaches to address hazards associated with overheating of REESS, GTR No. 20 provides three different options for terminating the discharge/charge cycles:

- (a) the vehicle terminates the charge-discharge cycle,
- (b) the REESS temperature gradient is less than or equal to 4 °C for a two-hour period, or
- (c) 3 hours have elapsed from the time of starting the discharge-charge cycles on the chassis dynamometer.

In accordance with GTR No. 20, the agency proposes to use the same three options listed above to terminate the discharge/charge cycle.

At the conclusion of the over-temperature evaluation, a standard cycle is performed if possible. The test concludes with a 1-hour observation period in which the vehicle is observed for electrolyte leakage, rupture, venting, fire, or explosion. At the conclusion of the observation period, the electrical isolation is determined in a similar manner as that in FMVSS No. 305 S7.6, using a voltmeter to measure voltages.

#### **v. External Short-circuit Protection**

The purpose of the external short-circuit protection test is to verify the performance of the vehicle controls (protection measure) against a short-circuit occurring externally to the REESS. During an external short-circuit event, large amounts of instantaneous current can be readily drawn generating copious amounts of heat. Associated safety risks include over-heating, gas venting, or arcing that can occur under fault conditions which can potentially lead to fire or explosion.

Vehicle controls or the BMS typically protect the REESS from an external short-circuit. GTR No. 20 includes a test to evaluate the performance of vehicle controls to protect the REESS from an external hard short-circuit (shorting resistance less than 5 milliohms). NHTSA tentatively concludes that GTR No. 20's external short-circuit test is practical and feasible based on the agency's own testing.<sup>74</sup> NHTSA proposes to include the GTR No. 20 external short-circuit protection requirement and test procedure in FMVSS No. 305a.

The external short-circuit test is performed on a complete vehicle. The SOC of the REESS at the beginning of the test is set at 90 to 95 percent SOC. The test is conducted at ambient temperatures between 10 °C and 30 °C. The breakout harness is installed on the vehicle at the manufacturer specified location(s).<sup>75</sup> Temperature probes are connected to the REESS case to monitor changes in the REESS temperature. Temperature measurements may also be obtained

---

<sup>74</sup> See Test reports in Docket No. NHTSA-2021-0029, available at [www.regulations.gov](http://www.regulations.gov). Detailed test procedures are provided in the test reports of the 2021 Chevrolet Bolt (NHTSA-2021-0029-0001), 2020 Nissan Leaf (NHTSA-2021-0029-0002), and the 2020 Tesla Model 3 (NHTSA-2021-0029-0003).

<sup>75</sup> If the manufacturer does not provide information on the location to connect the breakout harness for the external short circuit test, the breakout harnesses may be connected on either side of the positive and negative terminals of the pack.

through communication with the REESS control module. The short circuit contactor (with the contactors in open position) is connected to the breakout harnesses. The total resistance of the equipment to create the external short circuit (short circuit contactor and breakout harnesses) is verified to be between 2 to 5 milliohms.<sup>76</sup> To begin the short-circuit evaluation, the short-circuit contactors are closed. The short-circuit condition is continued until (1) current is no longer present or (2) one hour after the temperature probe on the REESS has stabilized with a temperature change of less than 4 °C for a two-hour period.

If possible, a standard cycle is performed after termination of the short-circuit. Fuses that opened during the short-circuit are not replaced, and the standard cycle procedure is not performed if it is not possible to charge and discharge the vehicle.

The vehicle is observed for one hour for electrolyte leakage, rupture, venting, fire, or explosion. The external short-circuit test concludes with an electrical isolation determination in a similar manner as that in current FMVSS No. 305a S7.6 using a voltmeter to measure voltages.

#### **vi. Low-temperature Protection**

Uncontrolled repeated operation at low temperatures, especially charging for lithium-ion battery chemistries, may result in lithium plating or cell damage that could eventually lead to reduced performance or degraded life during subsequent operation. While single time operation of REESS in very cold temperatures would not lead to a severe event, some REESS designs use special chemical reactions which can damage the REESS if it is charged at high rates in very cold temperatures. A subsequent high rate of charging of such a damaged REESS may lead to fire or explosion. Therefore, the rate of charging may need to be terminated or limited in very cold temperatures.

Currently, no practical test procedure is available to evaluate the performance of vehicle controls in low temperature conditions because the effects of repeated charging at very low

---

<sup>76</sup> GTR No. 20 specifies the external short circuit resistance not exceeding 5 milliohms. The agency is specifying a range from 2 to 5 milliohms for ease of conducting the tests and to ensure objectivity of the test.

temperatures occur over a very long period of time. Therefore, GTR No. 20 requires manufacturers to provide documentation that includes a system diagram, a written explanation on the lower boundary temperature for safe REESS operation, the method of detecting REESS temperature, and the action taken when the REESS temperature is at or below the lower boundary for safe REESS operation.

NHTSA proposes to include documentation requirements based on GTR No. 20 into FMVSS No. 305a. NHTSA proposes that the manufacturer provide documentation, upon NHTSA's request, to demonstrate how the vehicle monitors and appropriately controls REESS operations at low temperatures at or below the lower temperature boundary for safe REESS operation. The proposed requirements would indicate how manufacturers identify, verify, and ensure vehicles have low-temperature protections in place. Specifically, the proposal requires the manufacturer-supplied documentation for a specific vehicle make, model, and model year would include the following:

- (1) A description of the lower temperature boundary for safe REESS operation in all vehicle operating modes.
- (2) A description and explanation of C-rates at the lower temperature boundary for safe REESS operation.
- (3) A description of the method used to detect REESS temperature.
- (4) A system diagram with key components and subsystems involved in maintaining safe REESS charging and discharging operation for temperatures at or below the lower temperature boundary for safe REESS operation.
- (5) A description of how the vehicle controls, ancillary equipment, and design features were validated and verified for maintaining safe REESS operations at or below the lower temperature boundary for safe REESS operation.

(6) A description of the final review/audit process of the manufacturer, and the accompanying results of the manufacturer's final assessment of risk management, and risk mitigation strategies.

NHTSA intends these documentation measures to demonstrate that the manufacturer has considered, assessed, and mitigated identified risks for safe operation of the vehicle. NHTSA tentatively agrees with GTR No. 20 that there is a safety need for low temperature protections for the REESS. Without protections, uncontrolled repeated operation at low temperatures poses an unreasonable risk of fire or explosion. In the absence of information enabling NHTSA to propose a practical test procedure to evaluate the performance of vehicle controls in low temperature conditions, the agency is proposing to require manufacturers to submit documentation to NHTSA about pertinent low temperature safety hazards, describe their risk mitigation strategies for the safety hazards, and how they assessed the effectiveness of their mitigation strategies.

NHTSA would review the documentation to understand the safety hazards associated with the particular REESS in the vehicle, see whether the manufacturer conducted an assessment of the risks, and understand the measures the manufacturer undertook to mitigate those known risks. This approach is intended to evolve over time as battery technologies continue to rapidly evolve. It is an interim measure intended to assure that manufacturers will identify and address the low temperature safety risks of the REESS. In section VI., NHTSA requests comments on whether the proposed document requirement would be better placed in a general agency regulation than in proposed FMVSS No. 305a.

## **2. Mitigating Risk of Thermal Propagation Due to Internal Short within a Single Cell in the REESS**

### **i. Safety Need**

The potential for thermal runaway is a characteristic of the lithium-ion cells currently used in REESSs for electric vehicle propulsion. Thermal runaway of a lithium-ion cell in a REESS occurs when the thermal stability limit of the cell chemistry is exceeded, and the cell

releases its energy via an exothermic reaction at an uncontrolled rate such that heat is generated faster than it is dissipated. The thermal runaway in a single cell may propagate to the surrounding cells through conductive, convective, and radiative heat transfer modes, causing reactions which create smoke, fire or, in very rare circumstances, explosion. Lithium-ion cells have flammable electrolyte that upon decomposition provides oxygen to the fire caused by the thermal runaway, which increases the likelihood of its propagation to other cells and even outside the REESS. The self-oxygenating fires involving the cells in a REESS are therefore difficult to extinguish. The smoke, fire, toxic gas emissions, and explosion resulting from the thermal runaway can cause hazardous conditions for vehicle occupants and those near the vehicle.

One root-cause of single-cell thermal runaway (SCTR) and propagation due to an internal short-circuit relates to problems within the cells. While this NPRM contains many performance tests for the safe operation of the REESS, none of these tests would mitigate or prevent thermal runaway due to an internal short-circuit within a cell of the REESS and subsequent fire propagation. The mechanism of an internal short circuit in a cell is complex and requires further study. Currently, the risk of a spontaneous internal short circuit is heavily dependent on battery design, such as use of non-flammable electrolytes, ionic liquids, heat resistant and puncture-proof separators, and anode and cathode materials. However, as discussed below, a performance test that would establish a minimum standard of performance for the materials is not available now.

GTR No. 20 addresses the hazards associated with SCTR due to an internal short circuit through a documentation approach that requires manufacturers to provide (to the testing authority) information on risk mitigation strategies used in vehicle design to counteract the safety risk. GTR No. 20 also requires a warning system to allow vehicle occupants sufficient time to egress the vehicle before hazardous conditions are present in the passenger compartment due to

SCTR within the REESS. GTR No. 20 requires documentation of the warning system, and requires operation of the warning system only when the vehicle propulsion system is turned on.

NHTSA tentatively generally agrees that a documentation approach on risk mitigation strategies currently has merit, given there is no suitable performance test to validate mitigation or prevention of SCTR within a REESS. NHTSA is proposing a documentation approach based on GTR No. 20 but has focused the GTR's requirements to better address this safety need pending development of an objective performance test that can be applied to all REESSs in vehicles. In section VI., NHTSA requests comments on whether the proposed document requirement would be better placed in a general agency regulation than in proposed FMVSS No. 305a.

NHTSA is not proposing to require a warning system, or documentation of the warning system, as specified in GTR No. 20. As explained fully later in this section, NHTSA believes such a requirement would not mitigate the safety hazards observed in the field.

## **ii. GTR No. 20 Phase 1 Requirements**

GTR No. 20 recognizes that, in general, REESS cells are manufactured with manufacturing controls to mitigate safety problems. Based on current manufacturing control processes, the probability of manufacturing problems within a cell is generally considered to be less than one in a million.<sup>77</sup> Since the likelihood of two cells in a REESS going into spontaneous single-cell thermal runaway (SCTR) simultaneously is significantly lower,<sup>78</sup> the focus of GTR No. 20 is to mitigate the hazards associated with SCTR due to an internal short-circuit within a single cell.

GTR No. 20 addresses the SCTR safety hazard through a documentation approach that requires manufacturers to provide (to the testing authority on request) information on risk mitigation strategies used in vehicle design to counteract the safety risk, and documentation on a

---

<sup>77</sup> A REESS consists of a number of cells (n) in the range of 100 to 500. Therefore, the probability of a single-cell thermal runaway and propagation event due to an internal short-circuit is estimated to be the product of the number of cells times one in a million ( $n \times 10^{-6}$ ). <https://batteryuniversity.com/article/bu-304a-safety-concerns-with-li-ion#:~:text=Lithium%2Dion%20batteries%20have%20a,than%20those%20in%20consumer%20products>.

<sup>78</sup> The probability of two cells simultaneously undergoing single-cell thermal runaway and propagation due to an internal short-circuit is equal to the product of the probability of a single-cell thermal runaway ( $n^2 \times 10^{-12}$ ).

warning system that warns occupants to egress the vehicle. The documentation requirements for risk mitigation strategies are only generally described, however. This is because during the development of GTR No. 20, there was no significant evidence of electric vehicle fires due to SCTR and propagation due to an internal short-circuit. At that time, the thought was that vehicle occupants would be exposed to hazardous conditions if the SCTR propagates outside of the REESS to other parts of the vehicle. Therefore, GTR No. 20 focuses primarily on the warning and less on mitigating the risk of the SCTR within the cell. The GTR requires that a warning be provided to the driver 5 minutes before hazardous conditions are present in the passenger compartment due to SCTR and subsequent fire propagation. Five minutes was considered sufficient time for vehicle occupants to egress the vehicle before exposure to hazardous conditions. Under the GTR, manufacturers would satisfy the requirement for a warning by providing documentation that the vehicle provides the required warning.

GTR No. 20 uses a documentation approach for both the risk mitigation strategies and the warning because an objective test procedure is not available. Existing methods of initiating thermal runaway simulating an internal short-circuit within a single cell in a REESS are intrusive and dependent on the type of cell chemistry and cell type.<sup>79</sup> Additionally, different methods of initiation could result in different results.<sup>80</sup> NHTSA funded research to evaluate different thermal runaway propagation test methods by examining various existing methods of initiating thermal runaway, including heating element method, rapid heater method, nail penetration, and laser method, on batteries with a variety of chemistries, formats, and configurations.<sup>81</sup> The research

---

<sup>79</sup> One common method of initiating a thermal runaway is to heat a cell externally using a heating element. This would require disassembly of the casing of the REESS, adhering a heating element to the surface of a cell, and adding thermocouples to verify the heating element only provides heat to a single cell and not to adjacent cells. The amount of heat applied to initiate a thermal runaway depends on the cell chemistry (more volatile chemistries requiring less heat input), and the cell design/type (thick wall cells needing more heat input). The disassembly of the REESS, the addition of a heating element, and the heat input is intrusive to the REESS.

<sup>80</sup> Another method of initiating a thermal runaway in a cell is to penetrate a nail into a cell in the REESS. The orientation of the nail penetration depends on the cell design and in some instances, nail penetration may not cause a thermal runaway. While this method may not require the REESS casing to be opened, the penetrating nail compromises the casing and the cell structure. Additionally, the depth of nail penetration may result in differences in heat release that may not be similar in repeat tests and in tests using a heating element.

<sup>81</sup> Lamb, J., Torres-Castro, L., Stanley J., Grosso, C, Gray, L., “Evaluation of Multi-Cell Failure Propagation,” Sandia Report SAND2020-2802, March 2020. <https://www.osti.gov/servlets/purl/1605985>.

indicated that the thermal runaway initiation methods may influence the test results and the most appropriate initiation method for a battery may depend on battery chemistries, formats, and configurations.

The repeatability and reproducibility of a potential performance test using existing methods of thermal runaway initiation, and whether such a test could be conducted on all applicable vehicles, are unknown. Due to the rapid development of electric vehicle propulsion technology, it was unclear during development of the GTR if any existing performance test could apply to future vehicle designs without restricting further enhancement of electric vehicle propulsion systems. Therefore, instead of specifying a performance test for thermal runaway and propagation due to an internal short-circuit in a single cell of a REESS, GTR No. 20 requires manufacturers to submit documentation. Such documentation must show risk mitigation strategies in their vehicle designs for reducing hazards to vehicle occupants associated with thermal runaway due to an internal short-circuit in a single cell in the REESS. The documentation must also detail how the vehicle's warning system activates a warning at least 5 minutes before hazardous conditions arise in the passenger compartment.

Specifically, GTR No. 20 specifies the following documentation requirements:

- A description of the warning system.
- Parameters (such as voltage, temperature, or current) that trigger the warning indicator (telltale).
- A risk reduction analysis using appropriate industry standard methodology (for example, IEC 61508,<sup>82</sup> MIL-STD 882E,<sup>83</sup> ISO-26262,<sup>84</sup> fault analysis as in SAE J2929,<sup>85</sup> or

---

<sup>82</sup> IEC-61508:2010, "Functional Safety of Electrical/Electronic/Programmable Electronic Safety-related Systems". <https://webstore.iec.ch/searchform&q=IEC%2061508>

<sup>83</sup> MIL-STD-882E:2012, "System Safety".  
[https://quicksearch.dla.mil/qsDocDetails.aspx?ident\\_number=36027](https://quicksearch.dla.mil/qsDocDetails.aspx?ident_number=36027)

<sup>84</sup> ISO-26262 series:2018, "Road vehicles – Functional Safety". [https://www.iso.org/search.html?q=ISO-26262&hPP=10&idx=all\\_en&p=0&hFR%5Bcategory%5D%5B0%5D=standard](https://www.iso.org/search.html?q=ISO-26262&hPP=10&idx=all_en&p=0&hFR%5Bcategory%5D%5B0%5D=standard)

<sup>85</sup> SAE J2929:2013, "Safety Standard for Electric and Hybrid Vehicle Propulsion Battery Systems Utilizing Lithium-based Rechargeable Cells". [https://www.sae.org/standards/content/j2929\\_201302/](https://www.sae.org/standards/content/j2929_201302/)

similar), which documents the risk to vehicle occupants caused by a single-cell thermal runaway triggered by an internal short-circuit leading to thermal propagation and the expected risk reduction resulting from implementation of the identified risk mitigation functions or characteristics.

- A system diagram of all relevant physical systems and components which contribute to the protection of vehicle occupants from hazardous effects caused by thermal propagation triggered by a single-cell thermal runaway event due to an internal short-circuit.
- A diagram showing the functional operation of the relevant systems and components and identifying all relevant risk mitigation functions or characteristics.
- For each identified risk mitigation function or characteristic:
  - A description of its operation strategy,
  - Identification of the physical system(s) or component(s) which implements the function,
  - One or more of the following engineering documents relevant to the manufacturer's design which demonstrates the effectiveness of the risk mitigation function:
    - Tests performed including procedure used and conditions and resulting data,
    - Analysis or validated simulation methodology and resulting data.

### **iii. NHTSA Proposal**

NHTSA tentatively agrees with GTR No. 20's rationale for the documentation requirements for risk mitigation of thermal propagation events resulting from SCTR due to an internal short-circuit within a cell in the REESS. NHTSA tentatively concludes that due to the rapidly evolving REESS technology and control systems to manage the performance condition and safety of the REESS, a performance test to validate mitigation of thermal propagation resulting from SCTR within the REESS is not currently feasible. A performance test for a

warning, when the vehicle propulsion system is turned on, that provides sufficient time for vehicle occupants to egress the vehicle before hazardous conditions arise in the passenger compartment after a thermal runaway is initiated in a cell of the REESS would be unduly design restrictive, not applicable to all vehicle/REESS types, and not relevant to real world incidents.<sup>86</sup>

This NPRM proposes a documentation requirement for FMVSS No. 305a to require manufacturers to provide to NHTSA, upon NHTSA's request, information about their efforts to identify and address potential safety problems with SCTR and propagation due to an internal short-circuit. The information would be provided by a manufacturer in accordance with NHTSA's specified structure in four parts. NHTSA's proposed documentation component structure is based on elements from the GTR No. 20, ISO-6469-1: Amendment 1 2022-11,<sup>87</sup> and ISO-26262.<sup>88</sup> The documentation submitted by the manufacturer is required to include all known risks to vehicle occupants and bystanders, risk assessment, risk management, and risk mitigation strategies in three vehicle operational modes (i.e., external charging mode,<sup>89</sup> active driving possible mode,<sup>90</sup> and parking mode<sup>91</sup>). NHTSA's proposal goes beyond GTR No. 20's active driving possible mode to ensure manufacturers consider all risks known to it in three vehicle operational modes. The assessment and validation of these strategies may involve a

---

<sup>86</sup> In most real-world incidents resulting in fire due to thermal runaway of a single cell in the REESS, the vehicle was parked, with propulsion system turned off, and with no occupants in the vehicle. In some cases, the vehicles were parked in garages of homes. Therefore, a requirement for a warning to vehicle occupants in the vehicle with propulsion system turned on would not have helped prevent the fire or mitigated hazards to people in homes or in the vicinity of the burning parked vehicle.

<sup>87</sup> ISO 6469-1:Third Edition 2019-04 Amendment 1 2022-11, "Electrically propelled road vehicles – Safety specifications – Part 1: Rechargeable energy storage system (RESS)," specifies safety requirements for REESS, including test methodology for initiating thermal runaway in a cell for the purpose of conducting a thermal runaway propagation test and a format for reporting on risk mitigation strategies of thermal propagation resulting from a thermal runaway in a single cell of an REESS due to an internal short within the cell.

<sup>88</sup> ISO 26262: 2018, "Road vehicles – Functional safety," provides a comprehensive collection of standards to manage and implement road vehicle functional safety from concept phase to production and operation. The standard provides guidelines for overall risk management, individual component development, production, operation, and service.

<sup>89</sup> External charging mode is the vehicle operational mode in which the charge connector is connected to the vehicle charge inlet for the purpose of charging the REESS.

<sup>90</sup> Active driving possible mode is the vehicle mode when application of pressure to the accelerator pedal (or activation of an equivalent control) or release of the brake system causes the electric powertrain to move the vehicle.

<sup>91</sup> Parking mode is the vehicle mode in which the vehicle power is turned off, the vehicle propulsion system and ancillary equipment such as the radio are not operational, and the vehicle is stationary.

combination of physical testing and simulations at the component level and/or full vehicle level. The reporting requirements would apply to REESSs of all types (including REESS with non-flammable electrolyte).

The objective of the documentation is for vehicle manufacturers to identify the risks of single-cell thermal runaway and propagation for their REESS type, identify strategies to mitigate those risks, and demonstrate how those strategies work. The documentation would accomplish the following goals:

- It would identify all risks known to the manufacturer related to single-cell thermal runaway and propagation due to an internal short-circuit;
- It would discuss whether and how each identified risk is managed and/or mitigated by at least one risk mitigation strategy;
- It would explain the reasons the manufacturer believes each risk mitigation strategy is effective (measures taken to verify and/or validate them, including any final review/audit results); and,
- It would identify, describe, and provide any review/audit process and results that accompany the final assessment of risk management and risk mitigation strategies.

Proposed provisions to achieve the above goals are discussed in detail below.

The documentation requirement proposed by NHTSA is divided into four sections with more detailed requirements than GTR No. 20. Under the agency's requirements, in Part I, System Analysis, the vehicle manufacturer would provide information describing which conditions specific to the vehicle could lead to a SCTR event caused by an internal short-circuit. The conditions identified serve as the inputs to identify the functions and failure modes for the risk identification in Part II.

Part I would require the following documentation:

- A system diagram and a description of all relevant physical systems and components of the REESS, including information about the cell type and

electrical configuration, cell chemistry, electrical capacity, voltage, current limits during charging and discharging, thermal limits of the components that are critical for thermal propagation safety;

- A system diagram, operational description of sensors, components, functional units relevant to single-cell thermal runaway due to internal short-circuit and thermal propagation, and the interrelationship between the identified sensors, components, and functional units;
- A description of conditions under which a single-cell thermal runaway and propagation event due to an internal short-circuit could occur;
- A description of how the identified conditions are allocated to each identified component, functional unit, and subsystem;
- A description of the process used to review the identified conditions and their allocation to the identified sensors, components, and functional units, for completeness and validity; and
- A description of any system for warning or notification prior to the occurrence of thermal runaway in a cell, including a description of the detection technology and mitigation strategies, if any.

Part II, Safety Risk Assessment and Mitigation Process, provides a description of all identified safety risks and strategies to mitigate and manage these risks. Part II distinguishes between primary and secondary risk mitigation strategies. Primary risk mitigation strategies mitigate the risk of SCTR due to an internal short-circuit and the occurrence of thermal propagation that may result from SCTR. Primary risk mitigation strategies include manufacturing quality control to mitigate defects in cells of REESS, REESS design features such as heat sinks, cell spacing, coolant, advanced battery management system with prognostics and

diagnostics systems<sup>92</sup> to manage the health of the cells of an REESS and detect a possible thermal runaway condition before it occurs. In contrast, secondary risk mitigation strategies may not reduce the risk of thermal runaway or thermal propagation but reduce the hazards associated with thermal propagation. Secondary risk mitigation strategies include warning systems to vehicle occupants/bystanders and/or notification to emergency personnel in the event of thermal propagation (e.g., automatic notification to 911 operators). NHTSA anticipates that secondary risk mitigation strategies would be employed as an addition to primary risk mitigation strategies in the overall safety strategy.

Part II would require the following documentation:

- A description of safety risks and safety risk mitigation strategies, and how these were identified (e.g., Failure Mode and Effects Analysis (FMEA), or Failure Modes, Effects, and Criticality Analysis (FMECA));<sup>93</sup>
- A description of how each risk mitigation manages/mitigates the identified safety risks.

In Part III, Verification and Validation of Effective Risk Mitigation Strategies, the manufacturer provides information showing how they verify the effectiveness of the identified mitigation strategies in Part II to mitigate the identified safety risks. The vehicle level assessment examines how the entire vehicle monitors and mitigates safety risks. The vehicle level assessment is the culmination of the verification/validation results of each individual risk mitigation strategy.

Part III would require the following documentation:

- A summary of the process used to verify each identified risk is addressed by at least one risk mitigation strategy;

---

<sup>92</sup> Prognostic technologies predict the health of a system or a component of a system in the future and diagnostic technologies determine a specific problem with a system or component of a system.

<sup>93</sup> FMEA and FMECA are established methodologies to identify failure modes and postulate the effects of those failures on the system. Refer to <https://www.dau.edu/acquikipedia-article/failure-modes-effects-analysis-fmea-and-failure-modes-effects-criticality>

- A description of how each risk mitigation strategy was verified and validated for effectiveness;<sup>94</sup>
- A description of the verification and validation results for each risk mitigation strategy; and
- A vehicle level assessment evaluating the system response to safety risks associated with the REESS. Vehicle level assessment and validation could be the use of physical tests and/or validated models/simulations at a component level scaled up to evaluate the system response.

Part IV, Overall Evaluation of Risk Mitigation, shall address:

- Results of any final review/audit responsible for reviewing the technical content, completeness, and verity of the documentation submitted by the manufacturer.

The risk-based methodology outlined above is intended to mitigate the safety hazards associated with SCTR and propagation from an internal short-circuit. The requirement is intended to ensure that manufacturers are aware of the safety risks at issue and have considered safety risk mitigation strategies. The documentation submitted by the manufacturer will inform NHTSA of the safety risk mitigation strategies manufacturers have utilized for the identified safety hazards, enable NHTSA to oversee those safety hazards, and inform future regulatory measures.. This approach is battery technology neutral, not design restricted, and is intended to adapt over time as battery technologies continue to rapidly evolve. NHTSA seeks comment on the documentation requirements described above. In section VI., NHTSA requests comments on whether the proposed document requirement would be better placed in a general agency regulation than in proposed FMVSS No. 305a.

### **NHTSA’s Decision Not to Propose a Warning Requirement**

---

<sup>94</sup> Possible verification/validation methods for Part III include (but are not limited to) fault injection tests, software, and hardware performance tests at component and/or system level, and system level performance evaluation using validated mathematical models.

GTR No.20's warning requirement rationale is that the warning would allow vehicle occupants sufficient time to egress the vehicle before hazardous conditions are present in the occupant compartment. NHTSA does not agree with GTR No.20's rationale for a warning requirement related to SCTR due to an internal short-circuit within the cell. NHTSA is not proposing to require such a warning system, or documentation of the warning system, as specified in GTR No. 20 because such a requirement would not mitigate the safety hazards observed in the field, as described in detail below.

Field data and incidents related to SCTR and propagation due to an internal short-circuit in lithium-ion REESSs are sparse and anecdotal. However, when reviewing the limited number of non-crash and non-abuse related electric vehicle fire incidents in the United States,<sup>95</sup> the following trends emerge:

- The vehicle operation mode is in the usual parking mode.<sup>96</sup>
- The vehicle is parked in a garage attached to a house, a parking garage, or on the street.
- The state of charge (SOC) of the REESS was generally in the upper range.

Fire statistics reports by South Korea identified 35 electric vehicle fires since 2018, among which 20 electric vehicle fires originated in the REESS of the vehicles when the vehicle was parked and the SOC was greater than 90 percent.<sup>97</sup> In the electric vehicle fire incidents in the United States and South Korea, the vehicle fire propagated to adjacent vehicles and structures with release of copious amounts of smoke, resulting in significant property damage. The GTR No. 20 requirement for a warning to the driver would not have helped mitigate the electric vehicle fires and would not have mitigated property damage.

---

<sup>95</sup> E.g., Bolt EV Recall Information <https://experience.gm.com/recalls/bolt-ev>

<sup>96</sup> Usual parking mode is the vehicle operational mode in which the main software is "Off", the gear selector is in "P" (park), the energy supply is disconnected, the REESS power line is disconnected, the cooling system is not operational, the vehicle controls that manage safe operation of the REESS (e.g., Battery Management System) are not energized, and the vehicle occupants are typically not present.

<sup>97</sup> EVS23-E1TP-0200 [KR] EV Fire Records of Korea.pptx.  
<https://wiki.unece.org/display/trans/EVS+23rd+session>

Accordingly, this NPRM does not propose to require a warning to occupants or documentation pertaining to a warning, as such requirements would not sufficiently address a safety need. NHTSA believes the documentation requirements in GTR No. 20 for a warning to the driver are not relevant to the field-observed electric vehicle fires likely resulting from SCTR. NHTSA believes that vehicle designs using a risk mitigation strategy to mitigate or prevent the occurrence of SCTR incidents would better address the risks and hazards associated with spontaneous electric vehicle fires that originate within the REESS than a warning to egress the vehicle. This NPRM proceeds with NHTSA's preferred approach which would require documentation demonstrating that the manufacturer has considered and developed risk mitigation strategies to address SCTR in developing their electric vehicles.

### **GTR No. 20 Phase 2 Test Procedure Currently Under Consideration**

The IWG is continuing work on developing a test-based approach for SCTR due to an internal short-circuit in a single cell within the REESS. The plan is for a future regulation to require that the thermal propagation test procedure fulfill the following conditions:

1. Triggering of thermal runaway at a single-cell level must be repeatable, reproducible, and practicable,
2. Judgment of thermal runaway through common sensors, e.g., voltage and temperature, needs to be practical, repeatable, and reproducible, and
3. Judgment of whether consequent thermal events involve severe thermal propagation hazards, needs to be unequivocal and evidence based.

NHTSA discusses this work in the Appendix B to this preamble. Comments are requested that could assist the agency in future decisions on this matter.

### **3. Warning Requirements for REESS Operations**

As part of a risk-mitigation approach addressing multiple aspects of electrical system safety, NHTSA proposes requiring: (a) a thermal event warning; and (b) a vehicle control malfunction warning for drivers. The thermal event warning would be assessed by a performance

requirement, while the vehicle control malfunction warning would be a documentation requirement.

#### **i. Thermal Event Warning**

A “thermal event” presents an urgent safety critical situation. The term refers to a condition when the temperature within the REESS is significantly higher (as defined by the manufacturer) than the maximum operating temperature specified by the manufacturer. Thermal events within REESS could occur due to moisture and dust accumulation within the REESS that cause a short circuit at the connections or electronic components within the REESS. A thermal event within a battery pack can be a safety critical event, as it can lead to smoke, fire, and/or explosion. A warning provided about a thermal event within the REESS would reduce the likelihood of occupant exposure to smoke, fire, and/or explosion.

GTR No. 20 requires the vehicle to provide a warning to the driver in the case of a “significant thermal event” in the REESS (as specified by the manufacturer) when the vehicle is in active driving possible mode.<sup>98</sup> The GTR does not contain a performance test for the warning but instead requires manufacturers to provide documentation on the parameters that trigger the warning and a description of the system for triggering the warning. Specifically, the documentation requirements include:

- (1) Parameters and associated threshold levels that are used to indicate a thermal event (e.g., temperature, temperature rise rate, SOC level, voltage drop, electrical current, etc.) to trigger the warning.
- (2) A system diagram and written explanation describing the sensors and operation of the vehicle controls which manage the REESS in the event of a thermal event.

#### **NHTSA Proposal**

---

<sup>98</sup> Active driving possible mode means the vehicle mode when application of pressure to the accelerator pedal (or activation of an equivalent control) or release of the brake system causes the electric power train to move the vehicle.

NHTSA proposes to include a requirement for an audio and visual warning to the driver if a thermal event occurs in the REESS during the active driving possible mode. Instead of a documentation requirement as in the current GTR No. 20, NHTSA proposes a performance test to evaluate the required warning of a thermal event originating within the REESS.

NHTSA proposes to initiate the thermal event in the REESS by inserting a heater within the REESS that achieves a peak temperature of 600°C within 30 seconds. In the proposed test procedure, the REESS is removed from the vehicle, if possible, and the REESS casing is opened to attach the heater to a cell or cells in the REESS in a manner to put at least one cell in the REESS into thermal runaway. In this test, there is no need to restrict heating to a single cell within the REESS as the test is verifying activation of a warning when a thermal event occurs in the REESS regardless of the cause (e.g., an electric short between electronic components in the REESS, thermal runaway of multiple cells, etc.). Following installation of the heater in the REESS, the REESS casing is closed, the REESS is re-installed in the vehicle, and the vehicle propulsion system is turned on. The heater within the REESS is then activated. NHTSA proposes that the audio-visual warning must be activated within three minutes<sup>99</sup> of initiating the heater in the REESS. NHTSA has tentatively decided not to specify characteristics of the audio-visual warning to provide flexibility in how manufacturers communicate this safety critical information to vehicle occupants so they quickly egress the vehicle.

The proposed test is for evaluating appropriate activation of a required warning system when there is a thermal event in the REESS that could be hazardous to vehicle occupants.<sup>100</sup> NHTSA tentatively concludes that the proposed performance test to evaluate the warning system would not be design restrictive and can be conducted on all applicable vehicles. Therefore, a

---

<sup>99</sup> 3 to 5 minutes is considered to be sufficient time for able body individuals to evacuate light and heavy passenger vehicles before the occurrence of a hazardous event.  
<https://one.nhtsa.gov/reports/0900006480b01bbc.pdf>,

<sup>100</sup> This is unlike the risk management approach for SCTR where the goal is to mitigate hazards of thermal propagation (fire, smoke, gas emissions). Because risk management strategies for mitigating thermal propagation hazards due to SCTR differ considerably in vehicle designs, an objective performance test that can be conducted on all applicable vehicles is not available and so a documentation requirement is proposed.

performance test is proposed instead of adopting the documentation requirement in GTR No. 20. NHTSA seeks comment on the merits of the proposed performance test to evaluate the thermal event warning system instead of the documentation requirement in GTR No. 20. In addition, NHTSA seeks input on the type of heater, the heater characteristics (power, peak temperature) and possible locations of the heater within the REESS to simulate a thermal event to trigger the warning. While this NPRM does not require specific features of the audio-visual warning itself, comments are requested on what characteristics an effective audio-visual warning should have.

#### **ii. Warning in the Event of Operational Failure of REESS Vehicle Controls**

NHTSA is proposing to require that drivers be warned if there is a malfunction of vehicle controls that manage the safe operation of the REESS. This NPRM proposes a documentation approach for this type of warning, similar to GTR No. 20.

GTR No. 20 specifies that when the vehicle is in the active driving possible mode, the vehicle shall provide a warning telltale to the driver in the event of a malfunction of the vehicle controls that manage the safe operation of the REESS. GTR No. 20 requires manufacturers to provide documentation demonstrating that a warning to the driver will be provided in the event of malfunction of one or more aspects of vehicle controls that manage REESS safe operation. Specifically, vehicle manufacturers shall make the following documentation available to the testing authority:

- (1) A system diagram that identifies all the vehicle controls that manage REESS operation. The diagram must identify what components are used to generate a warning telltale indicating malfunction of vehicle controls to conduct one or more basic operations.
- (2) A written explanation describing the basic operation of the vehicle controls that manage REESS operation. The explanation must identify the components of the vehicle control system, provide description of their functions and capability to

manage the REESS, and provide a logic diagram and description of conditions that would lead to triggering the warning telltale.

### **NHTSA Proposal**

Vehicle controls manage several REESS operations, some of which are safety critical. There are multiple external fault scenarios<sup>101</sup> that could trigger a vehicle control to take corrective actions to ensure safe REESS operations. This NPRM includes performance requirements to address these external fault scenarios that assume proper functioning of the vehicle controls that manage safe REESS operations. However, if the vehicle controls that manage safe REESS operation are not functioning properly, the REESS may not be adequately protected from fault scenarios, which could lead to REESS degradation and eventually result in thermal propagation and other safety hazards. Therefore, it is important to notify the driver or front row occupants in the event there is malfunction of these vehicle controls that manage safe REESS operations.

Due to the complexity and varied designs of vehicle controls that manage REESS safe operation, no single test procedure could be developed that would fully evaluate whether a warning turns on in the event of operational failure of vehicle controls. Therefore, in accordance with GTR No. 20, this NPRM proposes to require manufacturers to provide a visual warning to the driver (e.g., like a check engine light) and documentation demonstrating that the visual warning will be provided in the event of operational failure of one or more aspects of vehicle controls that manage REESS safe operation.

NHTSA proposes the GTR No. 20 requirements for a visual warning to the driver of any malfunction of the REESS vehicle controls, and manufacturer documentation. In addition, NHTSA proposes to include two additional requirements that ensure manufacturers have validated functionality of the warning system:

---

<sup>101</sup> These fault scenarios include overcharge, over-discharge, overcurrent, external short-circuit, and overheating of the REESS.

- (1) Any validation test results by the vehicle manufacturer to confirm a visual warning is displayed in the presence of malfunction of the REESS operation vehicle controls.
- (2) A description of the final manufacturer review or audit process and results of any final review or audit evaluating the technical content and the completeness and verity of the documentation submitted by the manufacturer.

NHTSA tentatively concludes that a documentation approach is merited to demonstrate that the manufacturer has considered the effectiveness of a visual warning of the malfunction of the REESS operational vehicle controls. In the absence of information enabling NHTSA to propose a practical test procedure to evaluate the performance of a warning, the documentation approach ensures that manufacturers are aware of the safety risks at issue and have considered ways to address the risks. NHTSA would review the documentation to understand the visual warning associated with the particular REESS in the vehicle, see whether the manufacturer conducted an assessment of its effectiveness, and understand the measures the manufacturer undertook to validate such performance.

This approach is an interim measure intended to assure that manufacturers will identify, address, and validate the effectiveness of their visual warnings that help manage safe REESS operation. The approach is intended to evolve over time as battery technologies and NHTSA's information about the REESS safety risk mitigation strategies evolve. In section VI., NHTSA requests comments on whether the proposed document requirement would be better placed in a general agency regulation than in proposed FMVSS No. 305a.

#### **4. Protection Against Water Exposure**

NHTSA proposes to adopt GTR No. 20's physical water test requirement, where a vehicle shall maintain electrical isolation resistance after the vehicle is exposed to water under

normal vehicle operation, such as in a car wash or while driving through a pool of standing water. However, the agency is not proposing to adopt GTR No. 20's two other water exposure methods: documentation measures and warning requirements.

Environmental effects such as exposure to water and moisture may deteriorate the electrical isolation of high voltage components in the powertrain. This may first lead to an electric system degradation and eventually lead to an unsafe electrical system for vehicle occupants, operators (during charging) or by-standers. Under extreme conditions, fire can originate from compromised electrical components due to water ingress. GTR No. 20 contains water exposure shock protection specifications in which a vehicle shall maintain electrical isolation resistance after the vehicle is exposed to water under normal vehicle operation, such as during a car wash or driving through a pool of standing water.

NHTSA begins by noting that GTR No. 20 does not have specific requirements to address vehicle fires due to vehicle submersion such as floods and storm surges, and this NPRM is not covering that area. Floods are considered as catastrophic events, and as noted above, one of the principles for developing GTR No. 20 was to address unique safety risks posed by electric vehicles and their components to ensure a safety level equivalent to conventional vehicles with internal combustion engine (ICE). NHTSA continues to research the area of REESS performance post-submersions. This issue is discussed in more detail later in this section.

### **GTR No. 20 Requirements**

GTR No. 20 contains water exposure shock protection specifications in which a vehicle shall maintain electrical isolation resistance after the vehicle is exposed to water under normal vehicle operation. GTR No. 20 specifies three compliance options contracting parties may use in their regulations:

- Physical tests – (1) the vehicle is subjected to normal washing using a hose nozzle and conditions in accordance with IPX5, after which (2) the vehicle is driven in a freshwater wade pool (10 cm depth) over a total distance of 500 m at a speed of 20 km/hr for

approximately 1.5 minutes (min). The electrical isolation of high voltage sources in the electric powertrain are verified at the conclusion of each test and once again after 24 hours.

- Documentation – The vehicle manufacturers provide documentation certifying to IPX5<sup>102</sup> level waterproofing for protection of high voltage components in the vehicle. IPX5 is a waterproof rating that ensures protection against water ingress under sustained low pressure water jet stream (12.5 liters per minute at a pressure of 30 kilopascals (4.4 psi) from a distance of 3 meters) from any angle. The duration of the jet stream exposure is 1 minute per square meter surface area of the high voltage component.
- Warning –The vehicle has an electrical isolation loss warning system that warns the driver when electrical isolation falls below 100 ohms per volt for DC electrical components or 500 ohms per volt for AC electrical components. This option is available for individual countries to adopt if they so choose.

#### **i. NHTSA Proposal**

NHTSA tentatively concludes that the GTR No. 20's physical test option is a practical and feasible means of evaluating the effects of water exposure under normal vehicle operating conditions. It has advantages of a performance standard in assessing compliance over a documentation approach. Thus, the agency is not proposing the compliance option in GTR No. 20 of providing documentation on high voltage components meeting IPX5 level of protection.

Regarding the electrical isolation loss warning system option in GTR No. 20, NHTSA believes the warning signals alone are not sufficient for addressing loss of electrical isolation concerns. Where objective performance criteria are available and are appropriate for all types of vehicles to which the standard applies, NHTSA believes objective performance criteria should

---

<sup>102</sup> IEC 60529:1989/AMD2:2013, "Degrees of protection provided by enclosures (IP Code)."  
<https://webstore.iec.ch/publication/2446>

govern when compared to the approach of solely using a warning. The existence of the visual warning cannot necessarily be considered a safety prevention system, as the root cause of the safety hazard remains unaddressed, and the visual warning may be ignored by the driver.

Although visual warning indicators triggered from an isolation monitoring system could help mitigate safety concerns, NHTSA believes that this approach is not sufficient to solely mitigate a shock or fire hazard caused by the effects of water exposure. Thus, the agency does not propose this alternative as a compliance option in FMVSS No. 305a.

### **NHTSA Proposed Vehicle-Level Physical Test Procedures**

The proposed physical test procedure is comprised of two series of tests, informally referred to as the “vehicle washing” test and the “driving through standing water” test. Electrical isolation is determined at the conclusion of each test, and once again after 24 hours.

#### **A. Vehicle Washing Test**

The washing test exposes the vehicle to a stream of water such as when washing a car. The vehicle external surface, including the vehicle sides, front, rear, top, and bottom is exposed to the water stream. GTR No. 20 excludes the vehicle underbody from exposure to the water stream. However, since the vehicle underbody is often exposed to water when the vehicle is washed, NHTSA proposes to also expose the vehicle underbody to the water stream to make this test more representative of vehicle washing. The areas of the vehicle that are exposed to the water stream in any possible direction include border lines, i.e., a seal of two parts such as flaps, glass seals, outline of opening parts (windows, doors, vehicle inlet cover), outline of front grille and seals of lamps.

During the test, the vehicle is sprayed from any practicable directions with a stream of freshwater from a standard test nozzle as shown in Figure 4 below. The standard nozzle, with an internal diameter is 6.3 mm, shall provide a delivery rate of 11.9-13.2 liters/minute (l/min) with water pressure at the nozzle of 30-35 kilopascals (kPa) or 0.30-0.35 bar. These standard nozzle specifications are from IEC 60529 for IPX5 water jet nozzle.

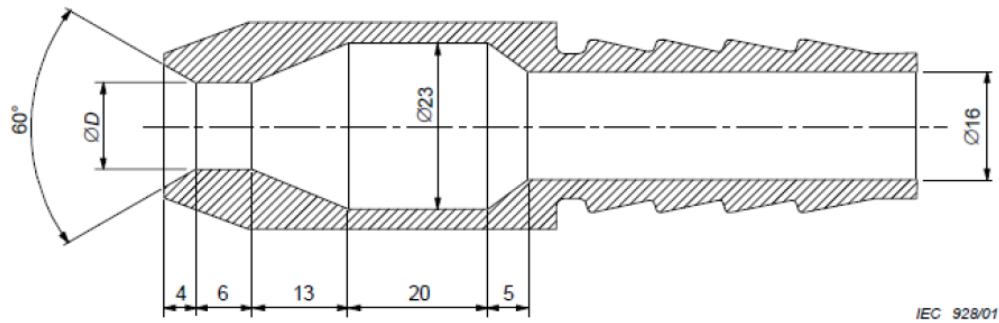

Dimensions in millimetres  
 D is 6.3 mm as specified in (a) above.

Figure 4 – Standard Nozzle (IEC 60529) for IPX5 Water Exposure Test

The vehicle surface is exposed to the water stream from the standard nozzle for a duration of 1 minute per square meter or for 3 minutes, whichever is greater. The distance from the nozzle to the tested vehicle is 3 meters, which may be reduced, if necessary, to ensure the surface is wet when spraying upwards.

After the “vehicle washing” test and with the vehicle surface still wet, electrical isolation is determined for high voltage sources in the same manner as that currently in S7.6 of FMVSS No. 305. The high voltage sources are required to meet the electrical isolation requirements as specified in S5.4.3 of current FMVSS No. 305.

Comments are requested on the merits of including the test in FMVSS No. 305a. NHTSA seeks comment on the representativeness of the washing test, including but not limited to the proposed test conditions (e.g., 30-35 kPa versus 80-100 kPa water pressure conditions, water salinity levels, and water exposure durations, etc.).

**B. Driving Through Standing Water Test**

NHTSA proposes that vehicles should also be subjected to GTR No. 20’s “driving through standing water” test. The vehicle is driven through a pool of standing freshwater,<sup>103</sup> 10 centimeters (cm) (4 inches) deep, for a total range of 500 meters (m), at a vehicle speed of 20

<sup>103</sup> Freshwater means water containing less than 1,000 milligrams per liter of dissolved solids, most often salt.

km/hr.<sup>104</sup> The pool represents a low-lying portion of a road that can get flooded in excessive rain. Meeting the test is a reasonable indication that the vehicle has safeguards to ensure electrical safety when driven through roads in inclement weather.

If the wade pool used is less than 500 m in length, then the vehicle is driven through the wade pool several times. The total time, including the periods outside the wade pool, would have to be less than 5 minutes. GTR No. 20 specifies a maximum test time of 10 minutes, but NHTSA believes that 5 minutes is preferable. Traversing 500 m at 20 km/hr takes 90 seconds. A maximum test duration of 10 minutes would allow for an excessive amount of time out of the water and may not be equivalent to a continuous 500 m exposure. NHTSA seeks comment on the maximum duration of this test. NHTSA also seeks comment on the availability and geometric dimensions of different types of wade pools (long rectangular, circular) to accomplish this type of test.

Just after the standing water test is completed and with the vehicle still wet, the vehicle would be required to meet the electrical isolation requirements now specified in FMVSS No. 305 S5.4.3 when tested in the same manner as described in S7.6 of current FMVSS No. 305. The vehicle is also required to meet the electrical isolation requirements that are in S5.4.3 of current FMVSS No. 305, 24 hours after the washing test and the standing water test are completed.

NHTSA seeks comment on the water salinity requirements for the physical tests as described above, including tolerances for the test parameters listed above.

## **ii. NHTSA's Consideration of Submersions**

In the U.S., floods resulting from Hurricane Sandy (2012), Hurricane Harvey (2017) and Hurricane Ian (2022) have led to electric vehicles submerged in flood waters for varying periods of time, with varying reports of vehicle fires in the aftermath. In developing this NPRM, the

---

<sup>104</sup> NHTSA tentatively concludes that the 10 cm (approximately four-inch) depth is reasonable, as national weather advisories ([https://www.weather.gov/tsa/hydro\\_tadd](https://www.weather.gov/tsa/hydro_tadd)) recommend not driving on flooded roads with more than four inches of water. Six inches of water on the road could reach the bottom of most passenger cars causing loss of control and possible stalling. A foot of water can float many vehicles.

agency considered whether it could propose requirements to address these types of vehicle submersions and the resulting risk of fire. NHTSA analyzed field data from these hurricanes and made the following key observations of vehicle fires resulting from the vehicle submersions:

- (1) Not all electric vehicles submerged in floods catch on fire. The type of water (water salinity), the level of submersion, and duration of submersion are likely factors;
- (2) Fire and other hazards are more likely after water exposure (days after flood waters recede) rather than during the exposure;
- (3) Fire may not originate in the REESS and may spread to the REESS from another vehicle component; and
- (4) While 12V systems may also short circuit and result in vehicle fire, fires involving lithium-ion REESS are more difficult to extinguish and more hazardous because of the self-oxygenating nature of the lithium-ion cells and the energy density of the REESS.

NHTSA evaluated the regulatory approaches taken by other countries to determine if such standards could assist NHTSA in addressing the challenges posed by the submersions and fires resulting from Hurricanes Sandy, Harvey, and Ian. NHTSA analyzed China and Korea's water exposure requirements but determined the focus of those standards do not appear to address the safety matter at issue. Key observations and findings from the field data in the U.S. and the exploratory investigation into the water exposure posed by the hurricanes suggest that the

test procedure and parameters and the performance requirements in China GB-38031<sup>105</sup> and the Korean Motor Vehicle Safety Standard (KMVSS)<sup>106</sup> may not be representative of field events of vehicle fires resulting from Hurricanes Sandy, Harvey, and Ian water exposure. If the standards are not representative of the harm NHTSA wishes to address from the hurricanes, the concern is the countermeasures to meet the performance test requirements of GB-38031 and KMVSS may not be effective at mitigating thermal events resulting from the water exposure at issue.<sup>107</sup>

Specifically, in both standards, the REESS is submerged in 3.5 percent salinity water representing seawater for a long period of time (two hours for GB-38031 and one hour for KMVSS). NHTSA's exploratory investigation of current REESS designs<sup>108</sup> suggests submersion in lower salinity water for a shorter duration may result in higher risk of thermal event. Longer immersion times in seawater salinity levels allow the batteries to safely discharge under water without adverse reactions such as arcing, venting, or underwater fires. Additionally, the requirements for no fire and explosion in these two standards are evaluated during the REESS immersion and not after the REESS is pulled out of the water. Such a requirement is not relevant to the electric vehicle fires observed after the flood waters in Hurricane Sandy and Hurricane Ian receded.

NHTSA acknowledges that the batteries in conventional vehicles with internal combustion engines (ICE) may also catch fire due to submersion. However, the post-submersion

---

<sup>105</sup> GB-38031 water immersion test contains two options. Option 1 is based on ISO-6469-1:2019 where the REESS is submerged in 1 meter of seawater (salinity of 3.5 percent) for two hours. The performance requirement for this test option is for no fire or explosion of the REESS during the submersion. Option 2 is based on ISO-20653, and requires IPX7 level waterproofing. In this test option, the REESS is completely submerged in regular water for 30 minutes such that the lower point of the battery is one meter below the surface or the highest point is 150 mm below the surface (for battery packs with a height greater than 850 mm). The performance requirement in this test option is for no water ingress, fire, or explosion, and the REESS maintains an electrical isolation of 100 ohms per volt after submersion. Option 1 of GB-38031 is intended for most current REESS (open-type or partially sealed) while Option 2 would necessitate a fully sealed REESS.

<sup>106</sup> KMVSS contains requirements for REESS, including a water immersion test that has been implemented in South Korea since 2009. In the water immersion test, the REESS is fully submerged in seawater (salinity of 3.5 percent) for one hour. The performance requirement in this test is for the REESS to not explode or catch on fire during the immersion. EVS19-E4WI-0300 [KR] Water Immersion Test.pptx.  
<https://wiki.unece.org/display/trans/EVS+19th+session>

<sup>107</sup> For instance, NHTSA's understanding is that most of the vehicles involved in Hurricane Ian's post-submersion fires had met China GB-38031.

<sup>108</sup> Li-Ion Battery Pack Immersion Exploratory Investigation, DOT HS 813 136, July 2021.  
<https://rosap.nhtl.bts.gov/view/dot/57013>.

vehicle fires after Hurricane Ian demonstrated that electric vehicle fires are more difficult to put out and therefore more hazardous than ICE vehicle fires. NHTSA believes that a better understanding of the field incidences of electric vehicle fires is needed before a field relevant test and performance requirements can be developed that addresses the observed safety risks associated with submersion of REESS and high voltage components in events such as floods.

The agency seeks comment on test conditions and test procedures that would address observed safety risks associated with submersion of REESS and high voltage components.

### **Going Forward**

Shortly after Hurricane Ian, NHTSA and other DOT agencies coordinated with emergency personnel in Florida to collect in-depth information on vehicle fire incidences and REESSs involved in the flooding.<sup>109</sup> This activity and others like it provided critical information that informed approaches to better protect vehicle owners, responders, and other stakeholders in the future.

In the near term, as discussed in sections below, this NPRM proposes to require that electric vehicle manufacturers submit standardized emergency response information to a NHTSA central depository, to assist first and second responders to respond to emergencies as quickly and safely as possible. The agency tentatively concludes that such a requirement would be an important and achievable near-term measure that NHTSA and the industry can take to mitigate the harm from these fires as work continues on vehicle-based mitigation methods. As part of NHTSA's activity going forward, NHTSA will document EV battery conditions after catastrophic flooding events and will commence new research into mitigation methods. The agency will obtain data to develop and improve EV tests relevant to salt-water immersion.

---

<sup>109</sup> NHTSA has purchased ten electric vehicles damaged during Hurricane Ian and plans to perform a teardown analysis to understand the root cause of the vehicle fires. The teardown analysis will inform the next steps to address the safety risks associated with vehicle submersions.

## **5. Miscellaneous GTR No. 20 Provisions Not Proposed**

There are several GTR No. 20 provisions for REESS performance during normal vehicle operations that NHTSA has not included in this NPRM. These provisions relate to requirements for: vibration, thermal shock and cycling, fire resistance, and low state-of-charge (SOC). Below is a description of the requirements and explanations of why NHTSA is proposing not to include the requirements. NHTSA requests comments on these views.

### **i. REESS Vibration Requirements**

GTR No. 20 contains a vibration requirement and test procedure to verify the safety performance of the REESS under a prescribed sinusoidal vibration environment that applies a generic vibration profile to the tested vehicle. NHTSA believes the vibration profile accelerations and frequencies are unique for each vehicle model and so applying a generic vibration profile to all vehicle models may not be appropriate. Additionally, the vibration environment in the test specified in GTR No. 20 is applied only in the vertical direction while in real world driving conditions, the REESS is subject to vibration along all three orthogonal axes. Therefore, the agency tentatively concludes that the vibration test in GTR No. 20 is not representative of the actual vibration environment for different vehicle models, or representative of real-world conditions that the REESS experiences.

Furthermore, vibration appears sufficiently addressed through other means. The market addresses this matter, as manufacturers routinely perform vibration testing to ensure customer satisfaction and reliability. Vehicle manufacturers assess the durability of the vehicle and its components (not just the REESS) through various road conditions with full vehicle simulation, either by driving on a rough road test track or simulating the lifetime fatigue on a vibration rig. Further, at the component level, electric vehicle batteries are currently subject to similar vibration test requirements for transportation under the United States Hazardous Materials

Regulations (HMR)<sup>110</sup> but along all three orthogonal axes and for frequencies up to 200 Hz.<sup>111</sup>

Thus, NHTSA believes that the GTR No. 20 vibration test would not address an additional safety need beyond what is already provided by HMR.

For the reasons stated in the paragraph above, NHTSA is not proposing the vibration test at a component level or the vehicle level.<sup>112</sup> Currently, during Phase 2 development of GTR No. 20, there are discussions for updating the vibration test to include vibration in all three orthogonal axes and at higher amplitudes and frequency range. In Appendix B of this preamble, the agency seeks public comment on the work in Phase 2 on the vibration test.

## **ii. REESS Thermal Shock and Cycling**

GTR No. 20's thermal shock and cycling requirement and test procedure aim to verify that the REESS is robust against thermal fatigue and contact degradation caused by temperature changes and potential incompatibilities of materials with varying thermal expansion characteristics.

At the component level, REESSs are already subject to thermal cycling test requirements for transportation under the HMR. 49 CFR 173.185 requires lithium-ion cells and batteries to comply with the test requirements in UN 38.3, including Test T2: Thermal test, which is the basis of the GTR No. 20 thermal shock and cycling test. In the UN38.3 Test T2, the REESS would be subject to temperature changes from -40 °C to +75 °C. This temperature range is greater than that prescribed in GTR No. 20. To avoid redundancy, NHTSA is not proposing the thermal shock and cycling test for the REESS. NHTSA tentatively concludes that incorporating the GTR No. 20 thermal shock and cycling test into FMVSS would not address additional safety needs beyond that already provided by HMR and 49 CFR 173.185. The agency seeks public

---

<sup>110</sup> 49 CFR parts 171 to 180, incorporated requirements for lithium batteries from UN 38.3 "Transport of dangerous goods: manual tests and criteria."

<sup>111</sup> 49 CFR 173.185 incorporated the vibration test 38.3.4.3 from the UN's "Recommendations on the Transport of Dangerous Goods, Manual of Tests and Criteria," <https://digitallibrary.un.org/record/483552?ln=en>.

<sup>112</sup> NHTSA and Transport Canada discussed in detail their positions for not including this vibration test during the development of GTR No. 20. See [https://wiki.unece.org/download/attachments/117508721/EVS21-E3VP-0101%5BOICA\\_UC\\_CA%5Dconsideration\\_of\\_vibration.pdf?api=v2](https://wiki.unece.org/download/attachments/117508721/EVS21-E3VP-0101%5BOICA_UC_CA%5Dconsideration_of_vibration.pdf?api=v2)

comment on the safety need of a REESS thermal shock and cycling requirement, and requests commenters provide data to substantiate their comments and/or assertions.

### **iii. REESS Fire Resistance**

This GTR No. 20 requirement is based on UN Regulation No. 34, “Uniform provision concerning the approval of vehicles with regard to the prevention of fire risks,”<sup>113</sup> which contains a fire resistance requirement for liquid fueled vehicle with plastic tanks. This test is required for REESSs installed in a vehicle at a height lower than 1.5 m above the ground and contain flammable electrolyte. During the test, the REESS is placed on a grating table positioned above the fire source in a pan. The pan filled with fuel is placed under the REESS in such a way that the distance between the level of the fuel in the pan and the bottom of the REESS corresponds to the design height of the REESS above the road surface at the unladed mass. The REESS is exposed directly to the flame for 70 seconds. A screen made of refractory material is then moved over the pan with the flame, such that the REESS is indirectly exposed to the flame for an additional 60 seconds. The screen and pan are then moved away from the REESS. The REESS is observed until the surface temperature of the REESS has decreased to the ambient temperature of the test environment. During the test, the REESS shall exhibit no evidence of explosion.

NHTSA tentatively concludes that the short duration of the GTR No. 20 fire resistance test would not address any safety risks associated with explosion resulting from external fire to the battery pack. Transport Canada conducted full vehicle gasoline pool fire tests of electric powered vehicles and similar vehicles with internal combustion engines and found that there was no explosion in tests of vehicles with REESS and those without. The Transport Canada tests indicated that the short duration of the GTR No. 20 external fire test would not result in explosion.<sup>114</sup> During Phase 1 of the GTR No. 20 discussions, the United States and Canada noted that including the short duration component level test in GTR No. 20 would not address a

---

<sup>113</sup> UN Regulation No. 34. <https://unece.org/fileadmin/DAM/trans/main/wp29/wp29regs/2013/R034r2e.pdf>

<sup>114</sup> <https://wiki.unece.org/download/attachments/29884786/EVSTF-07-02e.pdf?api=v2>

safety need and recommended removing it from GTR No. 20.<sup>115</sup> For these reasons, NHTSA is tentatively not proposing the short duration fire resistance test from GTR No. 20. The agency seeks comment on excluding this fire resistance requirement from the FMVSS, and requests commenters provide data to substantiate their comments and/or assertions.

#### **iv. Low State-of-Charge (SOC) Telltale**

GTR No. 20 requires a telltale to the driver in the event of low REESS SOC.<sup>116</sup> The agency is tentatively not including this telltale requirement for electric powered vehicles because there is no corresponding low fuel warning requirement for conventional vehicles with internal combustion engines. Low-fuel telltales are presently provided in all conventional vehicles due to consumer demand. Similarly, all electric-powered vehicles already provide low SOC telltales due to consumer demand. NHTSA seeks comment on whether this GTR No. 20 requirement should be incorporated into proposed FMVSS No. 305a, and if yes, what the telltale should look like.

#### **IV. Request for Comment on Applying FMVSS No. 305a to Low-Speed Vehicles**

Current FMVSS No. 305 applies to electric vehicles whose speed, attainable over a distance of 1.6 kilometers (km) (1 mile) on a paved level surface, is more than 40 km/h (25 miles per hour (mph)). It does not apply to vehicles that travel under 40 km/h (25 mph), such as low-speed vehicles.<sup>117</sup>

There are low-speed vehicles that are also electric-powered vehicles. NHTSA requests comments on applying aspects of FMVSS No. 305a to low-speed vehicles to ensure a level of protection against shock and fire, particularly during normal vehicle operation, and to assure the safe operation of the REESS. The agency requests comment on the possible applicability of

---

<sup>115</sup><https://wiki.unece.org/download/attachments/29884786/EVSTF-07-02e.pdf?api=v2>

<sup>116</sup> The GTR does not standardize the appearance of the telltale.

<sup>117</sup> “Low-speed vehicle” is defined in 49 CFR 571.3. See also FMVSS No. 500, “Low speed vehicles,” 49 CFR 500.

FMVSS No. 305a to low-speed vehicles and its relevant safety needs, including any supporting research on low-speed vehicles.

## **V. Emergency Response Information to Assist First and Second Responders**

Fires in electric vehicles are harder to extinguish than fires in vehicles with internal combustion engines and can reignite. These risks are also dependent on the specific vehicle design. Easy access to pertinent vehicle specific and emergency response information is vital for first and second responders when encountering electric vehicles. Safety is impeded when first and secondary responders are on scene but are delayed in their mitigation efforts because information on vehicle-specific safety mitigation methods are not easily accessible.

### **a. NTSB Report**

In 2020, NTSB published a safety report following a detailed investigation of four electric vehicle fires.<sup>118</sup> The investigation identified safety risks to first and second responders<sup>119</sup> from exposure to high voltage components and from vehicle fire due to damaged cells in the REESS that could reignite as a result of stranded energy in the REESS.<sup>120</sup> The NTSB investigation further identified the lack of a clear and standardized format in vehicle manufacturers' emergency response guides (ERGs)<sup>121</sup> and inadequacy in the information provided in the ERGs for first and second responders to minimize safety risks posed by stranded energy in the REESS while handling electric vehicles.

---

<sup>118</sup> Three of the vehicle fires occurred following severe crashes that resulted in significant damage to the REESS casing. One vehicle fire was caused by internal failure of the REESS during normal driving operations. "Safety risks to emergency responders from lithium-ion battery fires in electric vehicles," Safety Report NTSB/SR-20/01, PB2020-101011, National Transportation Safety Board, <https://www.nts.gov/safety/safety-studies/Documents/SR2001.pdf>.

<sup>119</sup> The NTSB report states, "First responders in this context refers to firefighters, but emergency medical technicians, paramedics, and police officers are also classified as first responders. Second responders in this context refers to tow truck drivers or tow yard operators, but they can also include those responsible for temporary traffic control or other support functions at a crash site."

<sup>120</sup> Stranded energy is the energy remaining inside the REESS after a crash or other incident. Cells in a compromised REESS could undergo thermal runaway at a later time and reignite the vehicle fire after firefighters extinguish the initial vehicle fire.

<sup>121</sup> Emergency Response Guides (ERGs) contain in-depth vehicle-specific information related to fire, submersion, leakage of fluids, towing, and storage of vehicles. The information is presented in a specific format with color-coded sections in a specific order to help first and second responders quickly identify pertinent rescue information. Rescue sheets contain abbreviated emergency response information about a vehicle's construction. Rescue sheets are most likely to be referenced first by emergency responders upon arrival at the scene of a crash. ERGs contain more information than rescue sheets.

NTSB issued recommendations to vehicle manufacturers, first and second responder organizations, and NHTSA. NTSB recommended manufacturers of electric vehicles to model their emergency response guides on International Standards Organization (ISO)-17840<sup>122</sup> and SAE International recommended practice SAE J2990, “Hybrid and EV first and second responder recommended practice.”<sup>123</sup> It recommended incorporating vehicle-specific information on (1) extinguishing REESS fires, (2) mitigating risk of REESS reignition, (3) mitigating safety risks (electric shock and fire) associated with stranded energy during emergency response and transport of damaged vehicle, and (4) storing damaged electric vehicles.

NTSB recommended to the vehicle manufacturers to follow the practices for first and second emergency responders available in SAE J2990<sup>124</sup> and ISO-17840. SAE J2990 mainly refers to the ISO-17840 for the emergency response information. As indicated earlier, ISO-17840 is comprised of four parts:

- ISO 17840-1:2022(E) standardizes the content and layout of rescue sheets for passenger cars and light commercial vehicles.
- ISO 17840-2:2019(E) standardizes the rescue sheets for buses, coaches, and heavy commercial vehicles.
- ISO 17840-3:2019(E) establishes a template and defines the general content for manufacturers’ emergency response guides for all vehicle types —longer documents that

---

<sup>122</sup> ISO-17840, “Road vehicles – Information for first and second responders,” consists of 4 parts: (1) Part 1 (2015): Rescue sheet for passenger cars and light commercial vehicles, (2) Part 2 (2019): Rescue sheet for buses, coaches, and heavy commercial vehicles, (3) Part 3 (2019): Emergency response guide template, and (4) Part 4 (2018): Propulsion energy identification. [https://webstore.ansi.org/standards/iso/iso178402015?gclid=Cj0KCQqiAtbqdBhDvARIsAGYnXBMNT9mR9gjsrKxd5kK8dK6V21QI9bDr8q2OI0fncMQHHpX\\_D8bQCxAaAhbUEALw\\_wcB](https://webstore.ansi.org/standards/iso/iso178402015?gclid=Cj0KCQqiAtbqdBhDvARIsAGYnXBMNT9mR9gjsrKxd5kK8dK6V21QI9bDr8q2OI0fncMQHHpX_D8bQCxAaAhbUEALw_wcB).

<sup>123</sup> SAE J2990 provides format and content recommendations for emergency response guides and quick reference sheets in accordance with ISO 17840. [https://www.sae.org/standards/content/j2990/2\\_202011/](https://www.sae.org/standards/content/j2990/2_202011/).

<sup>124</sup> SAE J2990 recommended practice provides common procedures to help protect emergency responders and personnel supporting towing and /or recovery, storage, repair, and salvage after an incident has occurred with an electric powertrain vehicle.

give in-depth “necessary and useful information” about a vehicle for emergency incidents.

- ISO 17840-4:2018 defines the labels and colors used to indicate the fuel or energy used to propel a vehicle for both the rescue sheets and the ERGs.

NTSB had two recommendations to NHTSA. The first recommendation was to factor the availability of a manufacturer’s ERG and its adherence to ISO 17840 and J2990 when determining a vehicle’s U.S. New Car Assessment Program (NCAP) score.<sup>125</sup> The second recommendation was to convene a coalition of stakeholders to continue research and publish the results on ways to mitigate or deenergize the stranded energy in high-voltage lithium-ion batteries and to reduce the hazards associated with thermal runaway resulting from high-speed, high-severity crashes.

NHTSA responded to NTSB by a letter dated April 2, 2021. Among other things, the letter said that NHTSA will be addressing risks to emergency responders by working directly with the emergency response community. The agency explained that NHTSA has partnered with the National Fire Protection Association (NFPA) to support the development of training to emergency responders on handling and managing fire incidents involving alternative fuel vehicles, including electric vehicles.<sup>126</sup> This NPRM is one result from our partnering with NFPA to provide emergency response guides to first and second responders.

NHTSA worked with other agencies and stakeholders and issued interim guidance in support of the development of training for emergency responders. In 2012 and 2014, NHTSA provided interim guidance to law enforcement, emergency medical services personnel and fire

---

<sup>125</sup> NHTSA’s NCAP is a consumer information program that evaluates the safety performance of vehicles and provides comparative information on new vehicles. NCAP also provides consumers with information on the availability of new vehicle safety features. This information is provided to assist consumers with vehicle purchasing decisions and to encourage safety improvements in vehicle design.

<sup>126</sup> <https://www.nhtsa.gov/sites/nhtsa.gov/files/2021-12/NHTSA-NTSB-Response-04-02-2021-Stranded-Energy-Lithium-Ion-Batteries-NCAP-Improvements-tag.pdf>

departments when encountering electric or hybrid-electric vehicles, to reduce the risk of shock hazards and vehicle fires following vehicle submersion.<sup>127</sup> NHTSA also provided separate interim guidance for towing and recovery operators and persons operating vehicle storage facilities.<sup>128</sup> NHTSA continues to lead an inter-agency<sup>129</sup> effort to develop updated guidance on best practices and strategies for emergency personnel to contain electric vehicle-related hazards from field events, such as electric vehicle fires resulting from storm surges like those occurring during Hurricane Ian.

#### **b. NHTSA Proposal The Information Must be Provided**

Current emergency response information is voluntarily filed on an NFPA website.<sup>130</sup> Rather than factoring the availability of ERGs as part of NCAP, NHTSA tentatively believes it would be more effective to address risks to emergency responders by directly requiring the standardized information. The information would be available and understandable to first and second responders so they can refer quickly and easily to identify pertinent vehicle-specific rescue information at the scene of the crash or fire event, and respond to the emergency quickly, effectively, and safely.

#### **The Information Must be Standardized**

To improve the ease and flow of information and, ultimately, the safety of persons involved, NHTSA is proposing a requirement that vehicle manufacturers submit the emergency response information to NHTSA in a standardized format. Currently, the ERGs and rescue sheets for alternative fuel vehicles available on the NFPA website is not in a standardized format.<sup>131</sup>

---

<sup>127</sup> *Interim Guidance for Electric and Hybrid-Electric Vehicles Equipped with High-Voltage Batteries* (located at [https://www.nhtsa.gov/sites/nhtsa.gov/files/811575-interimguidehev-hv-batt\\_lawenforce-ems-firedept-v2.pdf](https://www.nhtsa.gov/sites/nhtsa.gov/files/811575-interimguidehev-hv-batt_lawenforce-ems-firedept-v2.pdf).)

<sup>128</sup> “Interim Guidance for Electric and Hybrid-Electric Vehicles Equipped with High-Voltage Batteries,” located at [811576-interimguidehev-hv-batt\\_towing-recovery-storage-v2.pdf](https://www.nhtsa.gov/sites/nhtsa.gov/files/811576-interimguidehev-hv-batt_towing-recovery-storage-v2.pdf) (nhtsa.gov).

<sup>129</sup> U.S. Department of Energy, the United States Fire Administration, and the National Fire Protection Association.

<sup>130</sup> <https://www.nfpa.org/Training-and-Events/By-topic/Alternative-Fuel-Vehicle-Safety-Training/Emergency-Response-Guides>

<sup>131</sup> <https://www.nfpa.org/Training-and-Events/By-topic/Alternative-Fuel-Vehicle-Safety-Training/Emergency-Response-Guides>

The NTSB report indicated that a standardized format for ERGs would enhance emergency response as well as protect first and second responders. NHTSA tentatively believes this NPRM's proposed standardization requirement would make the information more understandable and would be another means that would help reduce response times and the safety risks to emergency responders.

Proposed FMVSS No. 305a would require that the rescue sheets must follow the layout and format in ISO-17840-1:2022(E) (for vehicles with a GVWR less than or equal to 4,536 kg (10,000 lb)) and the format in ISO-17840-2:2019(E) (for vehicles with a GVWR greater than 4,536 kg (10,000 lb)). ERGs must follow the template layout and format of ISO-17840-3:2019(E) and provide in-depth information linked and aligned to the corresponding rescue sheet to support the quick and safe action of emergency responders. The ERGs must also provide in-depth information related to electric vehicle fire, submersion, leakage of fluids, towing, transportation, and storage.

NHTSA seeks comment on the proposed format and layout of rescue sheets and ERGs in accordance with the different parts of ISO-17840. Are there main features of ISO-17840 that should be considered instead of referring to specific versions of the ISO-17840 parts? Are there specific features not included in ISO-17840 that would further enhance first and second responders' operations?

### **The Information Must be Vehicle-Specific**

NHTSA tentatively believes that, due to varying electric vehicle design and development, emergency response information must be vehicle-specific. Currently, the ERGs and rescue sheets on the NFPA website are not available for all vehicle makes, models, and model years. NHTSA tentatively believes that the information is of limited value because of this limited availability. The agency tentatively believes that requiring information on all vehicles is necessary to best reduce response times and the safety risks to emergency responders.

### **The Information must be Submitted to NHTSA**

NHTSA tentatively believes that easy access to both short and long forms of emergency response information are essential to address the risk of emergency responders. Therefore, as part of this NPRM and the NHTSA's battery safety initiative,<sup>132</sup> NHTSA is proposing a provision in FMVSS No. 305a that would require vehicle manufacturers to submit electronic versions of ERGs and rescue sheets for all vehicles to which FMVSS No. 305a applies, prior to certification of the vehicle, so that they are available in a centralized location on NHTSA's website. The rationale of submission prior to certification is to ensure the pertinent information for first and second responders are available by the time the vehicles are placed on public roads and potentially involved in emergencies. The intent is for both the ERGs and rescue sheets to be stored and maintained at a centralized web location (within NHTSA.gov), so that they are always easily and quickly accessible to all first and second responders.

#### **Other Issues Presented for Comment**

- To align with NHTSA's intent to have both ERGs and rescue sheets accessible in a centralized NHTSA web location, NHTSA would like to migrate the ERGs currently on the NFPA website to NHTSA's website. NHTSA requests comments on whether electric vehicle ERGs and rescue sheets that were previously hosted on the NFPA website should be included in NHTSA's centralized web location.
- NHTSA also requests comments on whether the requirement described in this section for ERGs and rescue sheets would be better placed in a general agency regulation than in proposed FMVSS No. 305a. NHTSA discusses this issue at length in section VI. of this preamble regarding documentation requirements pertaining to REESS safety risks and risk mitigation strategies identified by manufacturers. NHTSA requests comments on the pros and cons of having the ERGs and rescue sheet requirements in a regulation rather than in FMVSS No. 305a. Comments are requested on the pros and cons of placing the

---

<sup>132</sup> <https://www.nhtsa.gov/battery-safety-initiative>

requirement for providing ERG and rescue sheets to NHTSA to be in a regulation rather than in FMVSS No. 305a.

## **VI. Request for Comment on Placing the Emergency Response Information and Documentation Requirements in a Regulation Rather than in FMVSS No. 305a**

NHTSA requests comments on whether the proposed emergency response information requirements would be better placed in a general agency regulation than in proposed FMVSS No. 305a, given that the documentation specifications are more akin to a disclosure requirement (disclosing information to NHTSA) than a performance test or a consumer safety information requirement.

NHTSA regulates motor vehicle safety under many grants of authority. For example, one is that NHTSA is authorized by the Vehicle Safety Act to issue FMVSS; a typical FMVSS specifies minimum performance requirements and may also include provisions requiring manufacturers to provide consumers safety information on properly using a safety system or item of equipment. Another is that the Vehicle Safety Act authorizes NHTSA to require manufacturers to retain certain records and/or make information available to NHTSA. Section 30166 of the Act provides NHTSA the ability to request and inspect manufacturer records that are necessary to enforce the prescribed regulations. NHTSA is also authorized by delegation to issue regulations to carry out the agency's duties of ensuring vehicle safety.<sup>133</sup> Documentation requirements would be authorized under these authorities.

However, NHTSA is mindful that the mechanisms for enforcing a failure to meet a documentation requirement could differ depending on whether the requirement is in an FMVSS or not. Section 30118 of the Vehicle Safety Act (49 U.S.C. 30118) provides that whenever the Secretary of Transportation (NHTSA by delegation) determines that a vehicle does not comply with an FMVSS, NHTSA (by delegation) must require the vehicle's manufacturer to notify the

---

<sup>133</sup> 49 U.S.C. 322(a). This provision states that the Secretary of Transportation may prescribe regulations to carry out the duties and powers of the Secretary. The authority to implement the Vehicle Safety Act has been delegated to NHTSA.

owners, purchasers and dealers of the vehicle or equipment of the noncompliance and remedy the noncompliance. There is an exception to the recall requirement in section 30120(h) which authorizes NHTSA to exempt noncompliances from recall provisions based on a demonstration that the noncompliance is inconsequential to safety. In the case of a violation of a disclosure requirement in a regulation other than an FMVSS, the manufacturer could be subject to injunctive remedies and/or civil penalties,<sup>134</sup> but would not be subject to the recall notification and remedy provision described above. NHTSA requests comments on the pros and cons of placing the proposed emergency response information requirement in a regulation rather than in FMVSS No. 305a.

NHTSA also seeks comments on whether the proposed risk mitigation documentation requirements would be better placed in a general agency regulation. This NPRM proposes manufacturers to document and submit information, upon request, describing identified safety risks, risk mitigation strategies, and validation of those strategies. NHTSA has similar documentation requirements in FMVSS No. 126, “Electronic stability control systems for light vehicles”<sup>135</sup> and FMVSS No. 226, “Ejection Mitigation.”<sup>136</sup> NHTSA requests comments on the pros and cons of placing the proposed risk mitigation documentation requirement in a regulation rather than in FMVSS No. 305a.

## **VII. Proposed Compliance Dates**

The proposed compliance dates are as follows.

1. Regarding the proposed requirements other than the emergency response information to assist first and second responders, the compliance date would be two years after the publication of the final rule in the Federal Register. Small-volume manufacturers, final-stage manufacturers, and alterers would be provided an additional year to comply with the final rule

---

<sup>134</sup> See, e.g., 49 U.S.C. 30165.

<sup>135</sup> 49 CFR 571.126 S5.6

<sup>136</sup> 49 CFR 571.226 S4.2.4

beyond the two-year date identified above.<sup>137</sup> We propose to permit optional early compliance with the final rule.

Under § 30111(d) of the Safety Act, a standard may not become effective before the 180<sup>th</sup> day after the standard is prescribed or later than one year after it is prescribed, unless NHTSA finds, for good cause shown, that a different effective date is in the public interest and publishes the reasons for the finding. NHTSA has tentatively determined that a 2-year compliance period is in the public interest because all vehicle manufacturers need to gain familiarity with the proposed REESS requirements. There is already widespread conformance to the requirements so the 2-year period ought to provide sufficient time, but some manufacturers may need time to assess fleet performance, review their risk management procedures and document their mitigation strategies. Further, heavy vehicle manufacturers would be newly subject to electric system integrity requirements having not been subject to existing FMVSS No. 305. They will need time to assess their vehicles' conformance to FMVSS No. 305a requirements, implement appropriate design and production changes, and assess and document risk mitigation strategies.

2. Regarding requirements to provide emergency response information to assist first and second responders, the proposed compliance date is one year after publication of the final rule. Small-volume manufacturers, final-stage manufacturers, and alterers would be provided an additional year to comply with the final rule. Optional early compliance would be permitted. NHTSA believes the 1-year compliance date for this proposed requirement is long enough for manufacturers to provide the information to NHTSA in the required format. They are already providing the information voluntarily to the NFPA. The agency would like to provide the information on NHTSA's website as soon as possible. If manufacturers provide the information in a year, NHTSA can begin the process of posting the information shortly thereafter.

---

<sup>137</sup> 49 CFR 571.8(b).

## **VIII. Rulemaking Analyses and Notices**

### **Executive Order 12866, Executive Order 14094, Executive Order 13563, and DOT Order 2100.6A**

NHTSA has considered the impact of this rulemaking action under Executive Orders 12866, 14094, and 13563 and DOT Order 2100.6A. This action was not reviewed by the Office of Management and Budget under E.O. 12866.

This NPRM proposes to update FMVSS No. 305 to incorporate the electrical safety requirements in GTR No. 20 and issue FMVSS No. 305a with the incorporated requirements. Most of GTR No. 20 has already been adopted into FMVSS No. 305; this NPRM proposes to complete the process by expanding FMVSS No. 305's applicability to heavy vehicles and by adopting the GTR's requirements for the REESS. Since there is widespread conformance with the requirements that would apply to existing vehicles, we anticipate no costs or benefits associated with this rulemaking.

This NPRM also proposes a requirement that electric vehicle manufacturers submit standardized emergency response information to a NHTSA central depository, to assist first and second responders. A comprehensive list of pertinent vehicle specific rescue information at a central location will enable first and second responders to respond to emergencies as quickly and safely as possible. Currently, electric vehicle manufacturers voluntarily upload emergency response information to the National Fire Protection Association's training site, so manufacturers are already providing vehicle specific emergency response information. With this proposed rule, manufacturers would submit ERGs and rescue sheets to NHTSA instead. We anticipate no additional costs by the manufacturers.

### **Regulatory Flexibility Act**

NHTSA has considered the effects of this NPRM under the Regulatory Flexibility Act (5 U.S.C. 601 *et seq.*, as amended by the Small Business Regulatory Enforcement Fairness Act (SBREFA) of 1996). I certify that this NPRM, if promulgated, would not have a significant economic impact on a substantial number of small entities. NHTSA is aware of 3 small manufacturers of light and heavy electric vehicles. NHTSA believes that this proposed rule

would not have a significant economic impact on these manufacturers for the following reasons. First, small manufacturers of light electric vehicles that might be affected by this NPRM are already subject to the electric vehicle safety requirements of FMVSS No. 305 and have been certifying compliance to the standard for years. They are familiar with FMVSS requirements for electric vehicle safety, know how to assess the conformance of their vehicles with the requirements, and know how to certify their vehicles to the FMVSS. The new proposed requirements for the REESS are manageable because the overcharge, over-discharge, over-current, over-temperature, and external short-circuit tests are non-destructive tests and can be conducted in serial order. The documentation requirements for safety risk mitigation associated with charging and discharging during cold temperature, safety risk mitigation associated with an internal short-circuit in a single cell of a REESS, and warning in the event of a malfunction of the vehicle controls that manage REESS safe operation are not design restrictive and add minimal cost. The documentation requirements simply ask manufacturers to describe to NHTSA how they have assessed certain safety risks and mitigated them.

Second, there already is widespread voluntarily compliance by the manufacturers with GTR No. 20, which is also aligned with industry standards. Therefore, there will be only a minor economic impact.

Finally, although the final certification would be made by the manufacturer, this proposal would allow one additional year for small volume manufacturers, final-stage manufacturers and alterers to comply with a final rule. This approach is similar to the approach NHTSA has taken in other rulemakings in recognition of manufacturing differences between larger and smaller manufacturers. NHTSA anticipates that EV components meeting FMVSS No. 305a would be developed by vehicle designers and suppliers and integrated into the fleets of larger vehicle manufacturers first, before small manufacturers. This NPRM recognizes this and proposes to provide smaller manufacturers flexibility, so they have time to obtain the equipment and work with the suppliers after the demands of the larger manufacturers are met.

This NPRM would apply proposed FMVSS No. 305a to heavy vehicles, so this NPRM would also affect manufacturers of vehicles of over 4,536 kg (10,000 lb) GVWR, some of which may be final-stage manufacturers.<sup>138</sup> According to the U.S. Census, there are 570 small businesses in body manufacturing for light, medium, and heavy-duty classes. This proposal could affect a substantial number of final stage manufacturers that are small businesses. However, it is NHTSA's understanding that these small entities rarely make modifications to a vehicle's REESS system and instead rely upon the pass-through certification provided by the first-stage manufacturer, which is not typically a small business. The same is true for alterers, which are manufacturers that obtain and alter a complete vehicle prior to the vehicle's first sale to a consumer.<sup>139</sup> Furthermore, even if the final-stage manufacturer or alterer must make the certification independently, as explained above this certification responsibility is manageable. The proposed requirements do not involve crash testing (except for heavy school buses, as discussed below), and conformance with the requirements can be assessed relatively simply in a laboratory setting. And finally, this proposal would further accommodate final-stage manufacturers and alterers by providing them an additional year before compliance is required.<sup>140</sup> For the reasons above, NHTSA does not believe that the economic impacts of this proposal on small entities would be significant.

With regard to the proposed crash test requirement for small manufacturers of heavy school buses, the additional requirement is for heavy school buses with high voltage electric propulsion systems to meet post-crash electrical safety requirements when impacted by the moving contoured barrier specified in FMVSS No. 301. This requirement does not require additional crash testing and aligns the applicability of FMVSS No. 305a with that of FMVSS

---

<sup>138</sup> Final-stage manufacturers produce vehicles by obtaining an incomplete vehicle (comprising the chassis and other associated parts) manufactured by an incomplete vehicle manufacturer, which is typically a large manufacturer. The final-stage manufacturer produces a vehicle by installing the vehicle body on the incomplete vehicle. The final-stage manufacturer typically certifies a complete vehicle by staying within manufacturing instructions provided by the incomplete vehicle manufacturer.

<sup>139</sup> Alterers certify that the vehicle was altered by them and as altered conforms to all applicable FMVSS, bumper, and theft prevention standards affected by the alteration.

<sup>140</sup> See 49 CFR 571.8(b).

Nos. 301 and 303. Per FMVSS No. 301 and FMVSS No. 303, heavy school buses (school buses with a GVWR greater than 4,536 kg) using conventional fuel or compressed natural gas for propulsion are required to maintain fuel system integrity in a crash test where the moving contoured barrier specified in FMVSS No. 301 traveling at any speed up to 48 km/h impacts the school bus at any point and angle. These requirements ensure post-crash safety to maintain the current high safety standards for school buses. Finally, this proposal would accommodate small manufacturers and final stage manufacturers of heavy school buses by providing them an additional year before compliance is required. For the reasons above, NHTSA does not believe that the economic impacts of this proposal on small entities would be significant.

### **National Environmental Policy Act**

NHTSA has analyzed this rulemaking action for the purposes of the National Environmental Policy Act (42 U.S.C. 4321 *et seq.*), as amended. The agency has determined that implementation of this action will not have an adverse impact on the quality of the human environment. As described earlier, the proposal includes the current requirements in FMVSS No. 305 but would also expand the applicability of the standard to heavy vehicles (vehicles with a gross vehicle weight rating (GVWR) greater than 4,536 kilograms (kg) (10,000 lb)), add requirements to mitigate post-crash vehicle fires, add an optional method for assessing electrical safety for capacitors included in the electric powertrain, and include crash test and post-crash safety requirements for school buses with a GVWR greater than 4,536 kg (10,000 lb). The proposal would align the standard with electrical safety requirements in the Global Technical Regulation (GTR) No. 20, “Electric Vehicle Safety,” which has been formally adopted by the UN World Forum for Harmonization of Vehicle Regulations. The proposal, with expanded applicability and additional requirements and test procedures, would enable future updates to the standard as battery technologies and charging systems continue to evolve.

NHTSA expects the changes to new and existing vehicles to be minimal, and mitigating the hazards associated with electric shock during parked conditions, active drive-possible modes, external charging, and post-crash events, as well as risks associated with hazardous conditions

resulting from battery fires and emissions, would result in a public health and safety benefit. For these reasons, the agency has determined that implementation of this action will not have any adverse impact on the quality of the human environment.

### **Executive Order 13132 (Federalism)**

NHTSA has examined this proposed rule pursuant to Executive Order 13132 (64 FR 43255; Aug. 10, 1999) and concluded that no additional consultation with States, local governments, or their representatives is mandated beyond the rulemaking process. The agency has concluded that the proposal does not have sufficient federalism implications to warrant consultation with State and local officials or the preparation of a federalism summary impact statement. The proposal does not have “substantial direct effects on the States, on the relationship between the national government and the States, or on the distribution of power and responsibilities among the various levels of government.”

NHTSA rules can have preemptive effect in two ways. First, the National Traffic and Motor Vehicle Safety Act contains an express preemption provision: When a motor vehicle safety standard is in effect under this chapter, a State or a political subdivision of a State may prescribe or continue in effect a standard applicable to the same aspect of performance of a motor vehicle or motor vehicle equipment only if the standard is identical to the standard prescribed under this chapter. 49 U.S.C. 30103(b)(1). It is this statutory command that preempts any non-identical State legislative and administrative law address the same aspect of performance.

The express preemption provision described above is subject to a savings clause under which “[c]ompliance with a motor vehicle safety standard prescribed under this chapter does not exempt a person from liability at common law.” 49 U.S.C. 30103(e). Pursuant to this provision, State common law tort causes of action against motor vehicle manufacturers that might otherwise be preempted by the express preemption provision are generally preserved. However, the Supreme Court has recognized the possibility, in some instances, of implied

preemption of State common law tort causes of action by virtue of NHTSA's rules—even if not expressly preempted.

This second way that NHTSA rules can preempt is dependent upon the existence of an actual conflict between an FMVSS and the higher standard that would effectively be imposed on motor vehicle manufacturers if someone obtained a State common law tort judgment against the manufacturer—notwithstanding the manufacturer's compliance with the NHTSA standard. Because most NHTSA standards established by an FMVSS are minimum standards, a State common law tort cause of action that seeks to impose a higher standard on motor vehicle manufacturers will generally not be preempted. However, if and when such a conflict does exist—for example, when the standard at issue is both a minimum and a maximum standard—the State common law tort cause of action is impliedly preempted. See *Geier v. American Honda Motor Co.*, 529 U.S. 861 (2000).

Pursuant to Executive Order 13132, NHTSA has considered whether this proposed rule could or should preempt State common law causes of action. The agency's ability to announce its conclusion regarding the preemptive effect of one of its rules reduces the likelihood that preemption will be an issue in any subsequent tort litigation.

To this end, the agency has examined the nature ( *e.g.*, the language and structure of the regulatory text) and objectives of this proposed rule and does not foresee any potential State requirements that might conflict with it. NHTSA does not intend that this proposed rule preempt state tort law that would effectively impose a higher standard on motor vehicle manufacturers than that established by this proposed rule. Establishment of a higher standard by means of State tort law would not conflict with the standards proposed in this NPRM. Without any conflict, there could not be any implied preemption of a State common law tort cause of action.

#### **Executive Order 12988 (Civil Justice Reform)**

With respect to the review of the promulgation of a new regulation, section 3(b) of Executive Order 12988, “Civil Justice Reform” (61 FR 4729; Feb. 7, 1996), requires that

Executive agencies make every reasonable effort to ensure that the regulation: (1) Clearly specifies the preemptive effect; (2) clearly specifies the effect on existing Federal law or regulation; (3) provides a clear legal standard for affected conduct, while promoting simplification and burden reduction; (4) clearly specifies the retroactive effect, if any; (5) specifies whether administrative proceedings are to be required before parties file suit in court; (6) adequately defines key terms; and (7) addresses other important issues affecting clarity and general draftsmanship under any guidelines issued by the Attorney General. This document is consistent with that requirement.

Pursuant to this Order, NHTSA notes as follows. The issue of preemption is discussed above. NHTSA notes further that there is no requirement that individuals submit a petition for reconsideration or pursue other administrative proceedings before they may file suit in court.

#### **Privacy Act**

Please note that anyone is able to search the electronic form of all comments received into any of our dockets by the name of the individual submitting the comment (or signing the comment, if submitted on behalf of an association, business, labor union, etc.). You may review DOT's complete Privacy Act Statement in the **Federal Register** published on April 11, 2000 (65 FR 19477-78), or online at <http://www.dot.gov/privacy.html>.

#### **Paperwork Reduction Act**

Under the procedures established by the Paperwork Reduction Act of 1995 (PRA) (44 U.S.C. 3501, et. seq.), Federal agencies must obtain approval from the OMB for each collection of information they conduct, sponsor, or require through regulations. A person is not required to respond to a collection of information by a Federal agency unless the collection displays a valid OMB control number. The Information Collection Request (ICR) for the proposed new information collection described below have been forwarded to OMB for review and comment. In compliance with these requirements, NHTSA asks for public comments on the following proposed collections of information for which the agency is seeking approval from OMB.

There are two types of collection of information that are part of the proposed FMVSS No. 305a requirements: 1) Electric Vehicles: Rescue Sheets and Emergency Response Guides and 2) Electric Vehicles: REESS Thermal Propagation Safety Risk Analysis and Mitigation Documentation.

**Title:** FMVSS No. 305a Electric Vehicle Emergency Response Information and Risk Mitigation Documentation

**OMB Control Number:** New

**Form Number:** N/A

**Type of Request:** Approval of a new collection

**Type of Review Requested:** Regular

**Requested Expiration Date of Approval:** 3 years from the date of approval.

**Summary of the Collection of Information:**

FMVSS No. 305a proposes electric vehicle (EV) requirements for protection from harmful electric shock, fire, explosion, and gas venting during normal vehicle operation and during and after a crash. As part of the proposed requirements, there are two types of information collection that would apply to all electric vehicle (EV) manufacturers. First, before certification, each manufacturer will be required to submit emergency response information, including rescue sheets and emergency response guides (ERGs) for each vehicle make, model, and model year, so they are available in a centralized location on NHTSA's website. The information would then be readily available for first and second responders so they can easily identify pertinent vehicle-specific rescue information at the scene of a vehicle crash or fire event, and respond to the emergency quickly, effectively, and safely.

Second, each electric vehicle model will be required to meet three proposed documentation requirements and manufacturers will be required to submit to NHTSA, upon request, documentation demonstrating risk mitigation for certain safety hazards. The

documentation must describe safety risk mitigation associated with charging and discharging during cold temperature, safety risk mitigation associated with an internal short-circuit in a single cell of a REESS, and warning in the event of a malfunction of the vehicle controls that manage REESS safe operation.

**Description of the Need for the Information and Proposed Use of the Information:**

First responders need detailed information pertaining to an EV's electrical system layout in order to safely work around the vehicle and extricate injured passengers. Access to vehicle-specific information in a clear, standardized format help mitigate the safety risks of high voltage components and stranded energy in the Rechargeable Electrical Energy Storage System (REESS). The purpose of the requirement is to make this information readily available for first and second responders for their safe handling of the vehicle in emergencies and for towing and storing operations. Rescue sheets and ERGs communicate vehicle-specific information related to fire, submersion, and towing, as well as the location of components in the vehicle that may expose the vehicle occupants or rescue personnel to risks. The information is presented in a specific format with color-coded sections in a specific order to help first and second responders quickly identify pertinent rescue information. Rescue sheets contain abbreviated emergency response information about a vehicle's construction. Rescue sheets are most likely to be referenced first by emergency responders upon arrival at the scene of a crash. ERGs contain more information than rescue sheets.

Current emergency response information is voluntarily filed on the National Fire Protection Association (NFPA) website, but they are not in standardized format. The uploaded rescue sheets and ERGs would be standardized in layout and format and be publicly available at NHTSA's website for quick access.

There are currently no objective test procedures to evaluate REESS mitigation of certain safety risks in a manner that is not design restrictive. Until test procedures and performance criteria can be developed for all vehicle powertrain architectures, the proposed FMVSS No. 305a

would require manufacturers to compile and meet three of the proposed documentation requirements and submit documentation to NHTSA, if requested, that identifies all known safety hazards, the risk mitigation strategies for the safety hazards, and, if applicable, describe how they provide a warning to address a safety hazard. Given the variation of battery design and design-specific risk mitigation systems, the documentation is a means for manufacturers to show that they have identified and demonstrated safety risk mitigation strategies, and for NHTSA to learn of and oversee the safety hazards. This approach is battery technology neutral, not design restrictive, and is intended to evolve over time as battery technologies continue to rapidly evolve. These proposed documentation requirements would address: (a) safety risk mitigation associated with charging and discharging during low temperature; (b) the safety risks from thermal propagation in the event of SCTR due to an internal short-circuit of a single cell; and (c) providing a warning if there is a malfunction of vehicle controls that manage REESS safe operation.

**Affected Public:** Vehicle manufacturers.

**Frequency:** Emergency response information: as needed upon certification; Risk mitigation documentation: annually for recordkeeping.

**Number of Responses:** It is anticipated that an estimated 205 rescue sheets and ERGs will be submitted each year and all 205 unique models would be compiling and maintaining the required documentation annually.

Electric vehicle models encompass battery-powered electric vehicle, plug-in hybrid electric vehicle, hybrid electric vehicle, and fuel cell electric vehicle models. The combined number of electric vehicle models is estimated to be 205 unique models each year. Upon certification, a total of 205 rescue sheets and ERGs for all unique models will be submitted. Out of the 205 EV models, about 51 (25 % of EV models) likely already have rescue sheets and ERGs that conform to the proposed requirements. The number of new rescue sheets and ERGs that would be required to be compiled and submitted to NHTSA before certification is estimated

to be 51 (25 % of the combined EV models sold each year). NHTSA also anticipates updates to existing or previously submitted rescue sheets and ERGs for some vehicle models. Updates may be necessary when a vehicle model changes between model years or there are revisions to an existing model's emergency response information. It is estimated that approximately 103 (50 % of the 205 annual electric vehicle models) electric vehicle models sold each year would have updated or revised rescue sheets and ERGs. Because rescue sheets and emergency response guides often cover several model years, the percentage of models that would be needing new or updates to existing or previously submitted rescue sheets and ERGs are likely to decrease after the second year of the effective date.

**Estimated Total Annual Burden Hours:** 16,241 hours (2,506 hours for emergency response information and 13,735 hours for risk mitigation documentation).

For vehicle models that already have rescue sheets and ERGs that conform to the proposed requirements, it is estimated to take 0.25 hour to submit the required emergency response information to NHTSA's website. The estimated burden hours for the 51 EV models to submit their conformed rescue sheets and ERGs is 13 hours (0.25 hour/model × 51 models).

For each new electric vehicle model, it is anticipated that it will take approximately 36 hours to complete the vehicle-specific rescue sheet and emergency response guide following the required format and layout provided in ISO-17840-1:2022, ISO-17840-2:2019, and ISO-17840-3:2019. The estimated total annual burden hours for new rescue sheets and emergency response guides is 1,849 hours (36.25 hours/model × 51 models).

It is anticipated that it will take approximately 6 hours to update the rescue sheet and emergency response guide for a vehicle model. The estimated total annual burden hours for updated rescue sheets and emergency response guides is 644 hours (6.25 hours/model × 103 models). The estimated total annual burden hours is 2,506 hours.

For each vehicle model, vehicle manufacturers will need an estimated 67 hours to complete the three documentation requirements (17 hours to complete the documentation for low

temperature operation safety, 17 hours for the documentation about warning in the event of operational failure of REESS vehicle controls, and 33 hours for the documentation covering thermal runaway due to internal short in a single cell of the REESS). After the proposed rule's effective date, all 205 vehicle models are expected to compile the necessary information to meet the three proposed documentation requirements. The total estimated annual burden hours for the three documentation requirements is an estimate of 13,735 hours (205 vehicle models × 67 hours).

**Estimated Total Annual Burden Cost:** \$1,027,381 (\$157,543 for emergency response information and \$869,838 for risk mitigation documentation).

The preparation of information is anticipated to be done by a technical writer. The U.S. Bureau of Labor Statistics (BLS) estimates the mean hourly wage for technical writers in the motor vehicle manufacturing industry as \$44.71<sup>141</sup>. The BLS estimates that private industry workers' wages account for 70.6% of a worker's total compensation.<sup>142</sup> Therefore, NHTSA estimates the hourly labor costs to be \$63.33 (\$44.71/hour / 70.6%). The submission of information is anticipated to be done by an administrative professional. The U.S. BLS estimates the mean hourly wage for administrative professional in the motor vehicle manufacturing industry is \$29.36.<sup>143</sup> Therefore, NHTSA estimates the hourly labor costs for submission to be \$41.59 (\$29.36/hour / 70.6%).

These estimates produce an annual cost burden to manufacturers of \$116,804 (51 models × ((36 hours × \$63.33) + (0.25 hour × \$41.59)) for generating and submitting the emergency response information documentation for new models, \$40,209 (103 models × ((6 hours × \$63.33) + (0.25 hour × \$41.59)) for updating and submitting the documentation, and \$530 (51

---

<sup>141</sup> See May 2022 National Industry-Specific Occupational Employment and Wage Estimates, NAICS 336100 - Motor Vehicle Manufacturing, available at [https://www.bls.gov/oes/current/naics4\\_336100.htm](https://www.bls.gov/oes/current/naics4_336100.htm) (accessed February 29, 2024).

<sup>142</sup> See Table 1. Employer Costs for Employee Compensation by ownership (Sept. 2023), available at Table 1. By ownership - 2023 Q03 Results (bls.gov).

<sup>143</sup> See May 2022 National Industry-Specific Occupational Employment and Wage Estimates, NAICS 336100 - Motor Vehicle Manufacturing, available at [https://www.bls.gov/oes/current/naics4\\_336100.htm](https://www.bls.gov/oes/current/naics4_336100.htm) (accessed February 29, 2024).

models  $\times(0.25 \text{ hour} \times \$41.59)$ ) for those EV models that already conform to the proposed requirements for submission . The total labor cost to prepare and submit the emergency response information documentation to NHTSA's website is estimated to be \$157,543 annually.

Because rescue sheets and emergency response guides often cover several model years, the percentage of models that would be needing new or updates to existing or previously submitted rescue sheets and ERGs each year are likely to decrease in subsequent years. This would result in a reduction in annual total burden hours and annual total burden costs.

The preparation of the risk mitigation documentation is also anticipated to be done by a technical writer. The total cost burden for manufacturers for compiling and record keeping the three documentation packets would be \$869,838  $(205 \text{ vehicle models} \times (67 \text{ hours} \times \$63.33))$ .

The estimated total annual burden hours to manufacturers for the proposed FMVSS No. 305a emergency response information and documentation requirements would be 16,241 hours. The estimated total annual cost burden to manufacturers for the proposed FMVSS No. 305a emergency response information and documentation requirements would be \$1,027,381.

**Public Comments Invited:** You are asked to comment on any aspects of this information collection, including (a) whether the proposed collection of information is necessary for the proper performance of the functions of the Department, including whether the information will have practical utility; (b) the accuracy of the Department's estimate of the burden of the proposed information collection; (c) ways to enhance the quality, utility and clarity of the information to be collected; and (d) ways to minimize the burden of the collection of information on respondents, including the use of automated collection techniques or other forms of information technology.

Please submit any comments, identified by the docket number in the heading of this document, by the methods described in the ADDRESSES section of this document to NHTSA and OMB. Although comments may be submitted during the entire comment period, comments received within 30 days of publication are most useful.

## **National Technology Transfer and Advancement Act**

Section 12(d) of the National Technology Transfer and Advancement Act of 1995

(NTTAA), Public Law 104-113, as amended by Public Law 107-107 (15 U.S.C. 272), directs the agency to evaluate and use voluntary consensus standards in its regulatory activities unless doing so would be inconsistent with applicable law or is otherwise impractical. Voluntary consensus standards are technical standards (*e.g.*, materials specifications, test methods, sampling procedures, and business practices) that are developed or adopted by voluntary consensus standards bodies, such as the Society of Automotive Engineers (SAE). The NTTAA directs us to provide Congress (through OMB) with explanations when the agency decides not to use available and potentially applicable voluntary consensus standards.

This proposal to adopt GTR No. 20 is consistent with the goals of the NTTAA. This NPRM proposes to adopt a global consensus standard. The GTR was developed by a global regulatory body and is designed to increase global harmonization of differing vehicle standards. The GTR leverages the expertise of governments in developing a vehicle standard to increase electric vehicle safety, including the performance of the REESS. NHTSA's consideration of GTR No. 20 accords with the principles of NTTAA as NHTSA's consideration of an established, proven global technical regulation has reduced the need for NHTSA to expend significant agency resources on the same safety need addressed by GTR No. 20.

## **Unfunded Mandates Reform Act**

Section 202 of the Unfunded Mandates Reform Act of 1995 (UMRA), Public Law 104-4, requires Federal agencies to prepare a written assessment of the costs, benefits, and other effects of proposed or final rules that include a Federal mandate likely to result in the expenditure by State, local, or tribal governments, in the aggregate, or by the private sector, of more than \$100 million annually (adjusted for inflation with base year of 1995). Adjusting this amount by the implicit gross domestic product price deflator for the year 2022 results in \$177 million ( $111.416/75.324 = 1.48$ ). This NPRM would not result in a cost of \$177 million or more to either

State, local, or tribal governments, in the aggregate, or the private sector. Thus, this NPRM is not subject to the requirements of sections 202 of the UMRA.

### **Executive Order 13609 (Promoting Regulatory Cooperation)**

The policy statement in section 1 of Executive Order 13609 provides, in part: The regulatory approaches taken by foreign governments may differ from those taken by U.S. regulatory agencies to address similar issues. In some cases, the differences between the regulatory approaches of U.S. agencies and those of their foreign counterparts might not be necessary and might impair the ability of American businesses to export and compete internationally. In meeting shared challenges involving health, safety, labor, security, environmental, and other issues, international regulatory cooperation can identify approaches that are at least as protective as those that are or would be adopted in the absence of such cooperation. International regulatory cooperation can also reduce, eliminate, or prevent unnecessary differences in regulatory requirements.

The agency participated in the development of GTR No. 20 to harmonize the standards of electric vehicle. As a signatory member, NHTSA is proposing to incorporate electrical safety requirements and options specified in GTR No. 20 into FMVSS No. 305a.

### **Incorporation by Reference**

Under regulations issued by the Office of the Federal Register (1 CFR 51.5(a)), an agency must summarize in the preamble of a proposed or final rule the material it incorporates by reference and discuss the ways the material is reasonably available to interested parties or how the agency worked to make materials available to interested parties.

NHTSA proposes to incorporate by reference three documents into the Code of Federal Regulations. The first document is ISO 17840-1:2022 (E), “Road vehicles – Information for first and second responders – Part 1: Rescue sheet for passenger cars and light commercial vehicles.” ISO 17840-1:2022(E) standardizes the content and layout of rescue sheets for passenger cars and light commercial vehicles.

The second document is ISO 17840-2:2019(E), “Road vehicles – Information for first and second responders – Part 2: Rescue sheet for buses, coaches and heavy commercial vehicles.” ISO 17840-2:2019(E) standardizes the rescue sheets for buses, coaches, and heavy commercial vehicles.

The third document is ISO 17840-3:2019(E), “Road vehicles – Information for first and second responders – Part 3: Emergency response guide template.” ISO 17840-3:2019(E) establishes a template and defines the general content for manufacturers’ emergency response guides for all vehicle types.

All three documents would be incorporated by reference solely to specify the layout and format of the rescue sheets and emergency response guides. The ISO material is available for review at NHTSA and is available for purchase from ISO.<sup>144</sup>

### **Severability**

The issue of severability of FMVSSs is addressed in 49 CFR 571.9. It provides that if any FMVSS or its application to any person or circumstance is held invalid, the remainder of the part and the application of that standard to other persons or circumstances is unaffected.

Comments are requested on the severability of this proposed FMVSS.

### **Regulation Identifier Number**

The Department of Transportation assigns a regulation identifier number (RIN) to each regulatory action listed in the Unified Agenda of Federal Regulations. The Regulatory Information Service Center publishes the Unified Agenda in April and October of each year. You may use the RIN contained in the heading at the beginning of this document to find this action in the Unified Agenda.

### **Rulemaking Summary, 5 U.S.C. 553(b)(4)**

As required by 5 U.S.C. 553(b)(4), a summary of this rule can be found in the Abstract section of the Department’s Unified Agenda entry for this rulemaking at

<https://www.reginfo.gov/public/do/eAgendaViewRule?pubId=202304&RIN=2127-AM43>.

---

<sup>144</sup> ISO standards may be purchased from the ANSI webstore <https://webstore.ansi.org/>.

## **Plain Language**

Executive Order 12866 requires each agency to write all rules in plain language. Application of the principles of plain language includes consideration of the following questions:

- Have we organized the material to suit the public's needs?
- Are the requirements in the rule clearly stated?
- Does the rule contain technical language or jargon that isn't clear?
- Would a different format (grouping and order of sections, use of headings, paragraphing) make the rule easier to understand?
- Would more (but shorter) sections be better?
- Could we improve clarity by adding tables, lists, or diagrams?
- What else could we do to make the rule easier to understand?

If you have any responses to these questions, please write to us with your views.

## **IX. Public Participation**

*How long do I have to submit comments?*

Please see DATES section at the beginning of this document.

*How do I prepare and submit comments?*

- Your comments must be written in English.
- To ensure that your comments are correctly filed in the Docket, please include the Docket Number shown at the beginning of this document in your comments.
- Your comments must not be more than 15 pages long. (49 CFR 553.21). We established this limit to encourage you to write your primary comments in a concise fashion. However, you may attach necessary additional documents to your comments. There is no limit on the length of the attachments.
- If you are submitting comments electronically as a PDF (Adobe) File, NHTSA asks that the documents be submitted using the Optical Character Recognition (OCR)

process, thus allowing NHTSA to search and copy certain portions of your submissions. Comments may be submitted to the docket electronically by logging onto the Docket Management System website at <http://www.regulations.gov>. Follow the online instructions for submitting comments.

- You may also submit two copies of your comments, including the attachments, to Docket Management at the address given above under ADDRESSES.

Please note that pursuant to the Data Quality Act, in order for substantive data to be relied upon and used by the agency, it must meet the information quality standards set forth in the OMB and DOT Data Quality Act guidelines. Accordingly, we encourage you to consult the guidelines in preparing your comments. OMB's guidelines may be accessed at <http://www.whitehouse.gov/omb/fedreg/reproducible.html>. DOT's guidelines may be accessed at [http://www.bts.gov/programs/statistical\\_policy\\_and\\_research/data\\_quality\\_guidelines](http://www.bts.gov/programs/statistical_policy_and_research/data_quality_guidelines).

*How can I be sure that my comments were received?*

If you wish Docket Management to notify you upon its receipt of your comments, enclose a self-addressed, stamped postcard in the envelope containing your comments. Upon receiving your comments, Docket Management will return the postcard by mail.

*How do I submit confidential business information?*

You should submit a redacted "public version" of your comment (including redacted versions of any additional documents or attachments) to the docket using any of the methods identified under **ADDRESSES**. This "public version" of your comment should contain only the portions for which no claim of confidential treatment is made and from which those portions for which confidential treatment is claimed has been redacted. See below for further instructions on how to do this.

You also need to submit a request for confidential treatment directly to the Office of Chief Counsel. Requests for confidential treatment are governed by 49 CFR Part 512. Your request must set forth the information specified in Part 512. This includes the materials for which

confidentiality is being requested (as explained in more detail below); supporting information, pursuant to Part 512.8; and a certificate, pursuant to Part 512.4(b) and Part 512, Appendix A.

You are required to submit to the Office of Chief Counsel one unredacted “confidential version” of the information for which you are seeking confidential treatment. Pursuant to Part 512.6, the words “ENTIRE PAGE CONFIDENTIAL BUSINESS INFORMATION” or “CONFIDENTIAL BUSINESS INFORMATION CONTAINED WITHIN BRACKETS” (as applicable) must appear at the top of each page containing information claimed to be confidential. In the latter situation, where not all information on the page is claimed to be confidential, identify each item of information for which confidentiality is requested within brackets: “[ ].”

You are also required to submit to the Office of Chief Counsel one redacted “public version” of the information for which you are seeking confidential treatment. Pursuant to Part 512.5(a)(2), the redacted “public version” should include redactions of any information for which you are seeking confidential treatment (i.e., the only information that should be unredacted is information for which you are not seeking confidential treatment).

NHTSA is currently treating electronic submission as an acceptable method for submitting confidential business information to the agency under Part 512. Please do not send a hardcopy of a request for confidential treatment to NHTSA’s headquarters. The request should be sent to Dan Rabinovitz in NHTSA’s Office of the Chief Counsel (NCC) at Daniel.Rabinovitz@dot.gov. You may either submit your request via email or request a secure file transfer link. If you are submitting the request via email, please also email a courtesy copy of the request to K.Helena Sung in NCC at Helena.Sung@dot.gov.

*Will the agency consider late comments?*

We will consider all comments that Docket Management receives before the close of business on the comment closing date indicated above under DATES. To the extent possible, we will also consider comments that Docket Management receives after that date. If Docket

Management receives a comment too late for us to consider in developing the final rule, we will consider that comment as an informal suggestion for future rulemaking action.

*How can I read the comments submitted by other people?*

You may read the comments received by Docket Management at the address given above under ADDRESSES. The hours of the Docket are indicated above in the same location. You may also see the comments on the Internet. To read the comments on the Internet, go to <http://www.regulations.gov>. Follow the online instructions for accessing the dockets.

Please note that, even after the comment closing date, we will continue to file relevant information in the Docket as it becomes available. Further, some people may submit late comments. Accordingly, we recommend that you periodically check the Docket for new material.

## **X. Appendices to the Preamble**

### **APPENDIX A. Table Comparing GTR No. 20, FMVSS No. 305, and FMVSS No. 305a**

Table A below provides an overview of the requirements presently in the GTR No. 20, FMVSS No. 305, and the proposed FMVSS No. 305a for light vehicles (LVs) and heavy vehicles (HVs).

**Table A – Overview of Safety Requirements in GTR No. 20, FMVSS No. 305, and those proposed in this NPRM**

Requirement Category	Requirement	GTR No. 20	FMVSS No. 305	FMVSS No. 305a
Electrical Safety under Normal Vehicle Operations	Physical Barrier Protection			
	Electrical Isolation			
	Isolation Monitoring (FCEVs)	Yes for LV and HV	Yes for LV	Yes for LV and HV
	Charging Safety			
	Driver Error Mitigation			

Post-Crash Safety	REESS Retention	Yes for LV	Yes for LV	Yes for LV and heavy school bus
	Electrolyte Leakage		LV	
	Electrical Safety		No	
	Fire Safety			
Post-Crash Electrical Safety	Low Voltage	Yes for LV	Yes for LV	Yes for LV and heavy school bus
	Electrical Isolation		LV	
	Physical Barrier Protection			
Compliance Options	Low Energy (Capacitors)	Yes for LV	No	Yes for LV and heavy school bus
Optional Post-crash Component Level REESS Tests	Mechanical Crush Test instead of crash test	Yes for LV	No	No
	Mechanical Shock Test instead of crash test	Only shock test for HV		
REESS Safety Performance during Normal Vehicle Operations	Overcharge	Yes for LV and HV	No	Yes for LV and HV
	Over-Discharge			
	Over-Current			
	Over-Temperature			
	External Short-Circuit			
	Low-Temperature			
	Thermal Propagation			
	Water Exposure			
	REESS Venting			

	Vibration Thermal Shock & Cycling Fire Resistance	Yes for HV and LV	No	No
Warning Requirements	Thermal Event Warning	Yes for LV and HV	No	Yes for LV and HV
	Warning of Malfunction of Vehicle Controls for REESS Operations			
	Low SOC			No
Emergency Response Information	Rescue Sheets	No	No	Yes for LV and HV
	Emergency Response Guides (ERGs)			

**APPENDIX B. Request for Comment on Phase 2 GTR No. 20 Approaches Under Consideration by the IWG**

**1. Electrolyte Release and Venting From the REESS**

NHTSA requests comment on the IWG’s continuing work on venting. Phase 2 of GTR No. 20 is considering more robust methods to verify the occurrence and quantification of electrolyte release<sup>145</sup> and/or venting.<sup>146</sup> Two possible approaches for detection of electrolyte release are under consideration: (1) detection of solid and liquid Li-ion, and (2) gas detection for the vapors released from the liquid electrolyte and vented gases.

---

<sup>145</sup> EVS21-E2TG-0200 [EC]. Detection of electrolyte leakage by gas detection techniques. <https://wiki.unece.org/display/trans/EVS+21st+session>

<sup>146</sup> Gas emissions in thermal runaway propagation experiments, <https://wiki.unece.org/download/attachments/177242909/EVS25-E2TG-0400%20%5BEC%5DGas%20emissions%20in%20thermal%20runaway%20propagation%20experiments.pdf?api=v2>.

Chemosensors<sup>147</sup> are currently being studied to detect the presence of Li-ion resulting from electrolyte release. However, no commercially available chemosensors have been identified that could be used for testing purposes to reliably detect electrolyte leakage.

Common gas detection methods include gas chromatography, fourier-transform infrared spectroscopy (FTIR), and different types of gas sensors. Emitted gases under consideration include carbon dioxide (CO<sub>2</sub>), carbon monoxide (CO), hydrogen (H<sub>2</sub>), oxygen (O<sub>2</sub>), light C<sub>1</sub>-C<sub>5</sub> hydrocarbons, e.g., methane and ethane, and fluorine-containing compounds such as hydrogen fluoride (HF) and fluoro-organics such as e.g., ethyl-fluoride. However, practical, and cost-effective methods of sampling the leakage/emissions/venting and determining acceptable exposure levels for different gases are still under development.

NHTSA seeks comment on:

- How these detection methods (chemosensors and gas detection methods) may best be utilized in a vehicle level test procedure for both normal operating conditions and post-crash scenarios.
- How to best manage gases and particulates emitted from the REESS for both normal operating conditions and post-crash scenarios.
- Which gases generated in and vented from Li-ion batteries should be focused on for all types of REESS chemistries and are anticipated to remain relevant as REESS chemistry and technology changes in the future.
- Practicable methods to verify the occurrence of electrolyte release and venting and to quantify the vented gases and vapors.

## 2. Single-Cell Thermal Runaway

---

<sup>147</sup> Chemosensors indicate the presence of Li-ion through a color and fluorescence change. Chemosensor means a molecule which is able to simultaneously bind and signal the presence of other species. F. Pina et al, J. Photochem. Photobiol. A, 126 (1999), 65-69.

The IWG is considering a test-based approach during Phase 2 of GTR No. 20. GTR No. 20 would require that the thermal propagation test procedure fulfill the following conditions:

- Triggering of thermal runaway at a single-cell level must be repeatable, reproducible, and practicable,
- Judgment of thermal runaway through common sensors, e.g., voltage and temperature, needs to be practical, repeatable, and reproducible, and
- Judgement of whether consequent thermal events involve severe thermal propagation hazards, needs to be unequivocal and evidence based.

The two main initiation methods under consideration in Phase 2 are a localized rapid external heating method and a nail penetration method. The localized rapid external heating method is comprised of a film heater which is attached to an initiation cell's surface. The heater is turned on and set to reach its maximum power, and only turned off after thermal runaway occurs. In the nail penetration method, a steel nail 3 mm in diameter or more, with a circular cone is inserted into the initiation cell at a speed of 0.1 ~ 10 mm/s, which internally short-circuits the cell, inducing thermal runaway.

Current GTR No. 20 specifies three conditions in which thermal runaway can be detected:

1. The measured voltage of the initiation cell drops,
2. The measured temperature exceeds the maximum operating temperature defined by the manufacturer, and
3. The instantaneous rate of temperature change ( $dT/dt$ )  $\geq 1$  °C/s of the measured temperature.

Per GTR No. 20, thermal runaway can be judged when both (1) and (3) are detected, or both (2) and (3) are detected.

For the test procedure development, the only operational mode originally considered was the active driving possible mode. As discussions continue in Phase 2, other operational modes such as parking and externally charging are also under consideration. However, the test methods and performance criteria are still under development.

NHTSA conducted thermal runaway propagation tests on four different electric vehicle models using both the localized rapid external heating method<sup>148</sup> and the nail penetration (NP) method.<sup>149</sup> The criteria for identifying whether thermal runaway was initiated as described in ISO-6469-1:2019/DAM 1:2021(E) were used. Six tests were conducted at the vehicle level (with REESS installed in the vehicle) on four vehicle makes and models as shown in Table B-1.

Table B-1 - Thermal Runaway Propagation Tests using Two Different Methods of Initiating Thermal Runaway on a Single Cell

Vehicle Make, Model, and Model Year	Thermal Runaway Initiation Method	
	Localized External Rapid Heater Method	Nail Penetration Method
2019 Chevrolet Bolt	X	
2020 Nissan Leaf	X	
2020 Tesla Model 3	X, X (Two tests)	
2021 Chevrolet Bolt	X	X
2021 Nissan Leaf		X
2022 Kia Niro	X	X

Note - X represents a test was conducted.

Thermal runaway was initiated using the localized heating method in tests with both the 2019 and 2021 Chevrolet Bolt vehicles, the 2020 Nissan Leaf, 2020 Tesla Model 3, and the 2022 Kia Niro. Two tests using the localized heating method were conducted on the 2020 Tesla Model

<sup>148</sup> Thermal Runaway Initiation Method (TRIM) heater developed by the National Research Council (NRC) Canada.

<sup>149</sup> The testers used a generic nail similar to that specified in the ISO-6469-1:2019/DAM 1 1:2021(E).

3 because the first test did not result in a thermal runaway. Tests were conducted on the 2021 Chevrolet Bolt, 2021 Nissan Leaf, and the 2022 Kia Nero using the nail penetration method for initiating thermal runaway.

Significant information was needed from the manufacturers on opening up the battery pack and on selecting the cell for initiating thermal runaway using both methods. The selection of the cell for initiating thermal runaway was not random and was based on which cells were accessible; the cells were not necessarily those that are more likely to cause thermal propagation if a thermal runaway was initiated. Copious amounts of smoke were released within and outside of the passenger cabin before flames were observed. Some of the gas emissions include hydrogen (flammable) and carbon monoxide (toxic). All vehicles tested have REESSs with pouch cells except for the Tesla Model 3, whose REESS has cylindrical cells. In the first Tesla Model 3, the initial heater was unsuccessful in transferring heat into the target cell due to lack of back pressure on the heater. In the second test, the target cell went into thermal runaway but experienced a side wall rupture towards the outside of the battery pack.<sup>150</sup> The timing of the smoke emissions and the thermal propagation was not the same for the two methods of initiating thermal runaway in a single cell of the REESS. The results of the tests and the timing of various events are shown in Table B-2 below.

Table B-2 – Single-Cell Thermal Runaway and Propagation Test Results – Timing of Events

Method	Vehicle	External Smoke (min:sec)	Smoke In Cabin (min:sec)	External Flame (min:sec)	Warning Observed (min:sec)	Venting Observed (min:sec)	CO in ppm (min:sec)
TRIM	2019 Chevrolet Bolt	00:15	00:38	22:29	No	Yes	N/A
TRIM	2021 Chevrolet Bolt	00:17	01:10	08:17	Yes (00:51)	Yes	> 100 ppm (02:20) >1500 ppm (03:30)

<sup>150</sup> Side wall rupture does not represent thermal runaway events observed in the field.

NP	2021 Chevrolet Bolt	00:07	03:10	11:58	Yes (00:27)	Yes	> 100 ppm (07:30) >1200 ppm (08:58)
TRIM	2020 Nissan Leaf	00:25	04:45	31:09	Yes (00:45)	Yes	N/A
NP	2021 Nissan Leaf	00:05	01:10	24:48	Yes (00:34)	Yes	> 100 ppm (10:10) > 800 ppm (21:30)
TRIM	2020 Tesla Model 3	N/A	N/A	N/A	No	No	N/A
TRIM	2021 Tesla Model 3	00:28	N/A	N/A	No	Yes	N/A
TRIM	2022 Kia Niro	01:01	03:57	177:03	No	Yes	25 ppm (05:25)
NP	2022 Kia Niro	07:16	14:40	59:31	No	Yes	> 100 ppm (14:20)

For the localized rapid external heating method, the heating element parameter may vary depending on the different battery chemistries or cell type (e.g., large prismatic cells versus cylindrical cells).<sup>151</sup> More stable chemistries will require higher heat inputs than less stable chemistries. Calorimetric testing may need to be implemented to provide insights on what heating input parameters would be representative to avoid penalizing more stable cell chemistries, since they may require higher heat inputs to induce thermal runaway. The nail penetration method may be implemented in lieu of the localized rapid external heating method for more stable chemistries. It remains unclear whether the two initiation methods under consideration are equivalent in stringency. NHTSA’s research results indicate that the timing of thermal propagation is different for the different thermal runaway initiation methods for the same vehicle models. The rapid heating and nail penetration thermal runaway initiation methods can be applied to only some cells in the REESS or REESS subsystem; only the cells that can be accessed and modified without impinging on adjacent cells in the pack can be triggered in these

---

<sup>151</sup> ISO 6469-1:2019/DAM1:2021(E), “Electrically propelled road vehicles – Safety specifications – Part 1: Rechargeable energy storage system (RESS) – Draft Amendment 1.”

tests.<sup>152</sup> Additionally, the criteria for assessing whether thermal runaway has occurred in a cell needs further development.

Part of the performance criteria for a thermal runaway propagation test under consideration is for some form of warning to vehicle occupants and/or bystanders outside the vehicle in the event of thermal propagation within and outside the REESS. However, NHTSA considers warning to be a secondary mitigation strategy which would not prevent the thermal propagation from occurring in the first place. Thermal propagation resulting in EV fires are difficult to extinguish and may cause significant damage to adjacent structures and may pose a safety risk to people nearby, even when a warning is provided. In comparison, in the agency's view, the proposed documentation requirements provide a holistic risk mitigation of thermal propagation events resulting from single-cell thermal runaway due to an internal short-circuit within the cell. This risk mitigation would include of a cell in an REESS significantly before thermal runaway occurs to allow for appropriate action to be taken. Vehicle manufacturers are currently incorporating such technologies into the BMS to predict and evaluate the status of individual cells and mitigate the occurrence of single cell thermal runaway (SCTR) in the first place.

NHTSA seeks comment on the proposed reporting requirements to mitigate the risk of SCTR due to an internal short-circuit in a single cell of the REESS and the performance test under consideration in GTR No. 20 Phase 2.

### **3. REESS Vibration Requirements**

Currently, during Phase 2 development of GTR No. 20, there are discussions for updating the vibration test to include vibration in all three orthogonal axes and at higher amplitudes and frequency range. NHTSA seeks comment on the safety need that would warrant an update to a

---

<sup>152</sup> NHTSA's testing experience indicates that these testable cells are generally located along the edges of a module. The result of single-cell thermal runaway will vary with location based on heat transfer to adjacent cells and other components.

more stringent vibration test than that already in UN 38.3 Test T3.<sup>153</sup> NHTSA seeks comment from vehicle manufacturers on practices they have implemented to avoid reliability issues and assure customer satisfaction in the field.

### **List of Subjects in 49 CFR Part 571**

Imports, Incorporation by Reference, Motor vehicles, Motor vehicle safety.

### **Proposed Regulatory Text**

In consideration of the foregoing, NHTSA proposes to amend 49 CFR part 571 as set forth below.

#### **PART 571—FEDERAL MOTOR VEHICLE SAFETY STANDARDS**

1. The authority citation for part 571 continues to read as follows:

**Authority:** 49 U.S.C. 322, 30111, 30115, 30117, and 30166; delegation of authority at 49 CFR 1.95.

2. Section 571.5 is amended by adding paragraphs (i)(5), (i)(6), and (i)(7), to read as follows:

#### **§571.5 Matter incorporated by reference.**

\* \* \* \* \*

(i) \* \* \*

\* \* \*

(5) ISO 17840-1:2022 (E), “Road vehicles — Information for first and second responders — Part 1: Rescue sheet for passenger cars and light commercial vehicles,” Second Edition, February 2022, into § 571.305a.

---

<sup>153</sup> The vibration load spectrum in GTR No. 20 was derived from UN 38.3.4.3 “Recommendation on the Transport of Dangerous Goods, Manual of Tests and Criteria.”  
[https://unece.org/fileadmin/DAM/trans/danger/publi/manual/Rev7/Manual\\_Rev7\\_E.pdf](https://unece.org/fileadmin/DAM/trans/danger/publi/manual/Rev7/Manual_Rev7_E.pdf)

(6) ISO 17840 -2:2019 (E), “Road vehicles — Information for first and second responders — Part 2: Rescue sheet for buses, coaches and heavy commercial vehicles,” First edition, April 2019, into § 571.305a.

(7) ISO 17840-3:2019 (E), ” Road vehicles — Information for first and second responders — Part 3: Emergency response guide template,” First Edition, April 2019, into § 571.305a.

\* \* \* \* \*

3. Section 571.305a is added to read as follows:

**§ 571.305a Standard No. 305a; Electric-Powered Vehicles: Electric Powertrain Integrity; Mandatory applicability begins on (*this date will be the compliance date of the final rule*).**

S1. **Scope.** This standard specifies requirements for protection from harmful electric shock, fire, explosion, and gas venting during normal vehicle operation and during and after a crash.

S2. **Purpose.** The purpose of this standard is to reduce deaths and injuries during normal vehicle operations and during and after a crash that occur because of electrolyte leakage, intrusion of electric energy storage/conversion devices into the occupant compartment, electric shock, fire, explosion, and gas venting, including deaths and injuries due to driver error.

S3. **Application.** This standard applies to passenger cars, multipurpose passenger vehicles, trucks, and buses that use electrical propulsion components with working voltages greater than 60 volts direct current (VDC) or 30 volts alternating current (VAC), and whose speed attainable over a distance of 1.6 km on a paved level surface is more than 40 km/h.

S4. **Definitions.**

*Active driving possible* mode means the vehicle mode when application of pressure to the accelerator pedal (or activation of an equivalent control) or release of the brake system causes the electric power train to move the vehicle.

*Automatic disconnect* means a device that when triggered, conductively separates a high voltage source from the electric power train or the rest of the electric power train.

*Breakout harness* means connector wires that are connected for testing purposes to the REESS on the traction side of the automatic disconnect.

*Capacitor* means a device used to store electrical energy, consisting of one or more pairs of conductors separated by an insulator: x-capacitors are connected between electrical mains or neutral and y-capacitors are connected between a main to ground.

*Charge connector* is a conductive device that, by insertion into a vehicle charge inlet, establishes an electrical connection of the vehicle to an external electric power supply for the purpose of transferring energy.

*Chassis dynamometer* means a mechanical device that uses one or more fixed roller assemblies to simulate different road conditions within a controlled environment and is used for a wide variety of vehicle testing.

*Connector* means a device providing mechanical connection and disconnection of high voltage electrical conductors to a suitable mating component, including its housing.

*n C Rate* means the constant current of the REESS, which takes  $1/n$  hours to charge or discharge the REESS between 0 and 100 percent state of charge.

*Direct contact* is the contact of any person or persons with high voltage live parts.

*Electric energy storage device* means a high voltage source that stores energy for vehicle propulsion. This includes, but is not limited to, a high voltage battery or battery pack, rechargeable energy storage device, and capacitor module.

*Electric energy storage/conversion device* means a high voltage source that stores or converts energy for vehicle propulsion. This includes, but is not limited to, a high voltage battery or battery pack, fuel cell stack, rechargeable energy storage device, and capacitor module.

*Electric energy storage/conversion system* means an assembly of electrical components that stores or converts electrical energy for vehicle propulsion. This includes, but is not limited to, high voltage batteries or battery packs, fuel cell stacks, rechargeable energy storage systems, capacitor modules, inverters, interconnects, and venting systems.

*Electric power train* means an assembly of electrically connected components which includes, but is not limited to, electric energy storage/conversion systems and propulsion systems.

*Electrical chassis* means conductive parts of the vehicle whose electrical potential is taken as reference and which are:

- (1) conductively linked together, and
- (2) not high voltage sources during normal vehicle operation.

*Electrical isolation* of a high voltage source in the vehicle means the electrical resistance between the high voltage source and any of the vehicle's electrical chassis divided by the working voltage of the high voltage source.

*Electrical protection barrier* is the part providing protection against direct contact with high voltage live parts from any direction of access.

*Electrolyte leakage* means the escape of liquid electrolyte from the REESS.

*Emergency response guide* means a document containing in-depth vehicle-specific information related to fire, submersion, leakage of fluids, towing, and storage of vehicles for first and second responders.

*Exposed conductive part* is the conductive part that can be touched under the provisions of the IPXXB protection degree and that is not normally energized, but that can become

electrically energized under isolation fault conditions. This includes parts under a cover if the cover can be removed without using tools.

*External Charging mode* means the vehicle mode when the REESS is charging with external electric power supply connected through the charge connector to the vehicle charge inlet.

*External electric power supply* is a power supply external to the vehicle that provides electric power to charge the electric energy storage device in the vehicle through the charge connector.

*First responder* means a person with specialized training such as a law enforcement officer, paramedic, emergency medical technician, and/or firefighter.

*Fuel cell system* is a system containing the fuel cell stack(s), air processing system, fuel flow control system, exhaust system, thermal management system, and water management system.

*High voltage live part* means a live part of a high voltage source.

*High voltage source* means any electric component which is contained in the electric power train or conductively connected to the electric power train and has a working voltage greater than 30 VAC or 60 VDC.

*Indirect contact* is the contact of any person or persons with exposed conductive parts.

*Live part* is a conductive part of the vehicle that is electrically energized under normal vehicle operation.

*Luggage compartment* is the space in the vehicle for luggage accommodation, separated from the passenger compartment by the front or rear bulkhead and bounded by a roof, hood or trunk lid, floor, and side walls, as well as by electrical protection barriers provided for protecting the occupants from direct contact with high voltage live parts.

*Normal vehicle operation* includes operating modes and conditions that can reasonably be encountered during typical operation of the vehicle, such as driving, parking, and standing in

traffic, as well as charging using chargers that are compatible with the specific charging ports installed on the vehicle. It does not include conditions where the vehicle is damaged, either by a crash or road debris, subjected to fire or water submersion, or in a state where service and/or maintenance is needed or being performed.

*Parking mode* is the vehicle mode in which the vehicle power is turned off, the vehicle propulsion system and ancillary equipment such as the radio are not operational, and the vehicle is stationary.

*Passenger compartment* is the space for occupant accommodation that is bounded by the roof, floor, side walls, doors, outside glazing, front bulkhead and rear bulkhead or rear gate, as well as electrical protection barriers provided for protecting the occupants from direct contact with high voltage live parts.

*Propulsion system* means an assembly of electric or electro-mechanical components or circuits that propel the vehicle using the energy that is supplied by a high voltage source. This includes, but is not limited to, electric motors, inverters/converters, and electronic controllers.

*Protection degree IPXXB* is protection from contact with high voltage live parts. It is tested by probing electrical protection barriers with the jointed test finger probe, IPXXB, in Figure 7b.

*Protection degree IPXXD* is protection from contact with high voltage live parts. It is tested by probing electrical protection barriers with the test wire probe, IPXXD, in Figure 7a.

*Rechargeable Electrical Energy Storage System (REESS)* means the rechargeable electric energy storage system that provides electric energy for electrical propulsion.

*Rescue sheet* means an abbreviated version of an emergency response guide that gives quick information about a vehicle's construction, intended for use by first and second responders at the scene of a crash.

*Rupture* means an opening through the casing of the REESS that would permit the IPXXB test probe to penetrate and contact live parts.

*Second responder* means a worker who supports first responders by cleaning up a site, towing vehicles, and/or supporting services after an event requiring first responders.

*Service disconnect* is the device for deactivation of an electrical circuit when conducting checks and services of the vehicle electrical propulsion system.

*State of charge (SOC)* means the available electrical charge in a tested device expressed as a percentage of its rated capacity.

*Thermal event* means the condition when the temperature within the REESS is significantly higher than the maximum operating temperature.

*Thermal runaway* means an uncontrolled increase of cell temperature caused by exothermic reactions inside the cell.

*Thermal propagation* means the sequential occurrence of thermal runaway within a REESS triggered by thermal runaway of a cell in the REESS.

*VAC* means volts of alternating current (AC) expressed using the root mean square value.

*VDC* means volts of direct current (DC).

*Vehicle charge inlet* is the device on the electric vehicle into which the charge connector is inserted for the purpose of transferring energy and exchanging information from an external electric power supply.

*Venting* means the release of excessive internal pressure from cell or battery in a manner intended by design to preclude rupture or explosion.

*Working voltage* means the highest root mean square voltage of the voltage source, which may occur across its terminals or between its terminals and any conductive parts in open circuit conditions or under normal operating conditions.

## **S5. General Requirements.**

**S5.1 Vehicles of GVWR of 4,536 kilograms (kg) or less (light vehicles).** Each vehicle with a GVWR of 4,536 kg or less shall meet the requirements set forth in S6 (normal vehicle operation safety), S8 (post-crash safety), S11 (vehicle controls managing REESS safe

operations), S13.2 (thermal event in REESS warning), S14 (water exposure safety), and S15 (emergency response information).

**S5.2 Vehicles with a GVWR greater than 4,536 kg other than school buses (heavy vehicles other than school buses).** Each heavy vehicle with a GVWR greater than 4,536 kg, other than school buses, shall meet the requirements set forth in S6 (normal vehicle operation safety), S11 (vehicle controls managing REESS safe operations), S13.2 (thermal event in REESS warning), S14 (water exposure safety), and S15 (emergency response information).

**S5.3 School buses with a GVWR greater than 4,536 kg.** Each school bus with a GVWR greater than 4,536 kg shall meet the requirements set forth in S6 (normal vehicle operation safety), S8 (post-crash safety), S11 (vehicle controls managing REESS safe operations), S13.2 (thermal event in REESS warning), S14 (water exposure safety), and S15 (emergency response information).

**S6. Normal vehicle operation safety.** Each vehicle to which this standard applies must meet the requirements in S6.1 to S6.6, when tested according to the relevant provisions in S7.

**S6.1 Protection against direct contact.**

S6.1.1 *Marking.* The symbol shown in Figure 6 shall be present on or near electric energy storage devices. The symbol in Figure 6 shall also be visible on electrical protection barriers which, when removed, expose live parts of high voltage sources. The symbol shall be yellow and the bordering and the arrow shall be black.

S6.1.1.1 The marking is not required for electrical protection barriers that cannot be physically accessed, opened, or removed without the use of tools. Markings are not required for electrical connectors or the vehicle charge inlet.

S6.1.2 *High voltage cables.* Cables for high voltage sources which are not located within electrical protection barriers shall be identified by having an outer covering with the color orange.

S6.1.3 *Service disconnect.* For a service disconnect which can be opened, disassembled, or removed without tools, protection degree IPXXB shall be provided when tested under procedures specified in S7.3.1 using the IPXXB test probe shown in Figures 7a and 7b.

S6.1.4 *Protection degree of high voltage live parts.*

(a) Protection degree IPXXD shall be provided for high voltage live parts inside the passenger or luggage compartment when tested according to the procedures specified in S7.3.1 using the IPXXD test probe shown in Figure 7a.

(b) Protection degree IPXXB shall be provided for high voltage live parts in areas other than the passenger or luggage compartment when tested according to the procedures specified in S7.3.1 using the IPXXB test probe shown in Figures 7a and 7b.

S6.1.5 *Connectors.* All connectors shall provide direct contact protection by:

(a) Meeting the requirements specified in S6.1.4 when the connector is connected to its corresponding mating component; and,

(b) If a connector can be separated from its mating component without the use of a tool, meeting at least one of the following conditions from (b)(1), (2), or (3) of this section:

(1) The connector meets the requirements of S6.1.4 when separated from its mating component;

(2) The voltage of the live parts becomes less than or equal to 60 VDC or 30 VAC within one second after the connector is separated from its mating component; or,

(3) The connector requires at least two distinct actions to separate from its mating component and there are other components that must be removed in order to separate the connector from its mating component and these other components cannot be removed without the use of tools.

S6.1.6 *Vehicle charge inlet.* Direct contact protection for a vehicle charge inlet shall be provided by meeting the requirements specified in S6.1.4 when the charge connector is

connected to the vehicle inlet and by meeting at least one of the requirements of subparagraphs (a) or (b).

(a) The vehicle charge inlet meets the requirements of S6.1.4 when the charge connector is not connected to it; or

(b) The voltage of the high voltage live parts becomes equal to or less than 60 VDC or equal to or less than 30 VAC within 1 second after the charge connector is separated from the vehicle charge inlet.

### **S6.2 Protection against indirect contact.**

S6.2.1 The resistance between all exposed conductive parts of electrical protection barriers and the electrical chassis shall be less than 0.1 ohms when tested according to the procedures specified in S7.3.2

S6.2.2 The resistance between any two simultaneously reachable exposed conductive parts of the electrical protection barriers that are less than 2.5 meters from each other shall be less than 0.2 ohms when tested according to the procedures specified in S7.3.2.

### **S6.3 Electrical isolation.**

S6.3.1 *Electrical isolation of AC and DC high voltage sources.* The electrical isolation of a high voltage source, determined in accordance with the procedure specified in S7.2 must be greater than or equal to one of the following:

(a) 500 ohms/volt for an AC high voltage source;

(b) 100 ohms/volt for an AC high voltage source if it is conductively connected to a DC high voltage source, but only if the AC high voltage source meets the requirements for protection against direct contact in S6.1.4 and the protection from indirect contact in S6.2; or

(c) 100 ohms/volt for a DC high voltage source.

S6.3.2 *Exclusion of high voltage sources from electrical isolation requirements.* A high voltage source that is conductively connected to an electric component which is conductively connected to the electrical chassis and has a working voltage less than or equal to 60 VDC, is not

required to meet the electrical isolation requirements in S6.3.1 if the voltage between the high voltage source and the electrical chassis is less than or equal to 30 VAC or 60 VDC.

*S6.3.3 Electrical isolation of high voltage sources for charging the electric energy storage device.* For the vehicle charge inlet intended to be conductively connected to the AC external electric power supply, the electric isolation between the electrical chassis and the high voltage sources that are conductively connected to the vehicle charge inlet during charging of the electric energy storage device shall be greater than or equal to 500 ohms/volt when the charge connector is disconnected. The electrical isolation is measured at the high voltage live parts of the vehicle charge inlet and determined in accordance with the procedure specified in S7.2. During the measurement, the electric energy storage device may be disconnected.

**S6.4 Electrical isolation monitoring.** DC high voltage sources of vehicles with a fuel cell system shall be monitored by an electrical isolation monitoring system that displays a warning for loss of isolation when tested according to S7.4. The system must monitor its own readiness and the visual warning display must be provided to the driver. For a vehicle with autonomous driving systems and without manually-operated driving controls, the visual warning must be provided to all the front row occupants.

**S6.5 Electric shock protection during charging.** For motor vehicles with an electric energy storage device that can be charged through a conductive connection with a grounded external electric power supply, a device to enable conductive connection of the electrical chassis to the earth ground shall be provided. This device shall enable connection to the earth ground before exterior voltage is applied to the vehicle and retain the connection until after the exterior voltage is removed from the vehicle.

**S6.6 Mitigating driver error.**

*S6.6.1 Indicator of active driving possible mode.* At least a momentary indication shall be given to the driver each time the vehicle is first placed in active driving possible mode after manual activation of the propulsion system. This requirement does not apply under conditions

where an internal combustion engine directly or indirectly provides the vehicle's propulsion power when the vehicle is first placed in the active driving possible mode after manual activation of the propulsion system.

*S6.6.2 Indicator of active driving possible mode when leaving the vehicle.* When leaving the vehicle, the driver shall be informed by an auditory or visual signal if the vehicle is still in the active driving possible mode.

*S6.6.3 Prevent drive-away.* If the on-board electric energy storage device can be externally charged, vehicle movement of more than 150 mm by its own propulsion system shall not be possible as long as the charge connector of the external electric power supply is physically connected to the vehicle charge inlet in a manner that would permit charging of the electric energy storage device.

**S7. Electrical safety test procedures for normal vehicle operation safety.** The following provisions specify the test procedures associated with the requirements of S6.

**S7.1 Voltage measurements.** For the purpose of determining the voltage level of the high voltage source, voltage is measured as shown in Figure 1 using a voltmeter that has an internal resistance of at least 10 M $\Omega$ . All post-crash voltage measurements for determining electrical isolation of high voltage sources specified in S8.2(a), the voltage levels specified in S8.2(b), and the energy in capacitors specified in S8.2(d) are made between 10 to 60 seconds after impact.

**S7.1.1** For a high voltage source that has an automatic disconnect that is physically contained within itself, the voltage measurement after the test is made from the side of the automatic disconnect connected to the electric power train or to the rest of the electric power train if the high voltage source is a component contained in the power train. For a high voltage source that has an automatic disconnect that is not physically contained within itself, the voltage measurement after the test is made from both the high voltage source side of the automatic disconnect and from the side of the automatic disconnect connected to the electric power train or

to the rest of the electric power train if the high voltage source is a component contained in the power train.

S7.1.2 Voltage  $V_b$  is measured across the two terminals of the voltage source. Before a vehicle crash test,  $V_b$  is equal to or greater than the working voltage as specified by the vehicle manufacturer.

S7.1.3 Voltage  $V_1$  is measured between the negative side of the high voltage source and the electrical chassis as shown in Figure 2. Voltage  $V_2$  is measured between the positive side of the high voltage source and the electrical chassis as shown in Figure 3.

**S7.2 Test method for determining electrical isolation.** Measure the voltages  $V_1$ ,  $V_2$ , and  $V_b$  as shown in Figure 1 in accordance with S7.1

S7.2.1 If  $V_1$  is greater than or equal to  $V_2$ , insert a known resistance ( $R_o$ ) between the negative side of the high voltage source and the electrical chassis. With the  $R_o$  installed, measure the voltage ( $V_1'$ ) as shown in Figure 4 between the negative side of the high voltage source and the electrical chassis. Calculate the electrical isolation resistance ( $R_i$ ) according to the formula shown. Divide  $R_i$  (in ohms) by the working voltage of the high voltage source (in volts) to obtain the electrical isolation (in ohms/volt).

S7.2.2 If  $V_2$  is greater than  $V_1$ , insert a known resistance ( $R_o$ ) between the positive side of the high voltage source and the electrical chassis. With the  $R_o$  installed, measure the voltage ( $V_2'$ ) as shown in Figure 5 between the positive side of the high voltage source and the electrical chassis. Calculate the electrical isolation resistance ( $R_i$ ) according to the formula shown. Divide  $R_i$  (in ohms) by the working voltage of the high voltage source (in volts) to obtain the electrical isolation (in ohms/volt).

**S7.3 Test methods for evaluating physical barrier protection.**

S7.3.1 *Test method to evaluate protection from direct contact with high voltage sources.*

(a) Any parts surrounding the high voltage components are opened, disassembled, or removed without the use of tools.

(b) The selected access probe is inserted into any gaps or openings of the electrical protection barrier with a test force between 9 Newton to 11 Newton with the IPXXB probe or 1 Newton to 2 Newton with the IPXXD probe. If the probe partly or fully penetrates into the electrical protection barrier, it is placed in every possible position to evaluate contact with high voltage live parts. If partial or full penetration into the electrical protection barrier occurs with the IPXXB probe, the IPXXB probe shall be placed as follows: starting from the straight position, both joints of the test finger are rotated progressively through an angle of up to 90 degrees with respect to the axis of the adjoining section of the test finger and are placed in every possible position.

(c) A low voltage supply (of not less than 40 V and not more than 50 V) in series with a suitable lamp may be connected between the access probe and any high voltage live parts inside the electrical protection barrier to indicate whether high voltage live parts were contacted.

(d) A mirror or fiberscope may be used to inspect whether the access probe touches high voltage live parts inside the electrical protection barrier.

(e) Protection degree IPXXD or IPXXB is verified when the following conditions are met:

(1) The access probe does not touch high voltage live parts. The IPXXB access probe may be manipulated as specified in S7.3.1(b) for evaluating contact with high voltage live parts. The methods specified in S7.3.1(c) or S7.3.1(d) may be used to aid the evaluation. If method S7.3.1(c) is used for verifying protection degree IPXXB or IPXXD, the lamp shall not light up.

(2) The stop face of the access probe does not fully penetrate into the electrical protection barrier.

*S7.3.2 Test method to evaluate protection against indirect contact with high voltage sources.* Any parts surrounding the high voltage components are opened, disassembled, or removed without the use of tools. At the option of the manufacturer, protection against indirect

contact with high voltage sources shall be determined using the test method in subparagraph (a) or subparagraph (b).

(a) *Test method using a resistance tester.* The resistance tester is connected to the measuring points (the electrical chassis and any exposed conductive part of electrical protection barriers or any two simultaneously reachable exposed conductive parts of electrical protection barriers that are less than 2.5 meters from each other), and the resistance is measured using a resistance tester that can supply current levels of at least 0.2 Amperes with a resolution of 0.01 ohms or less. The resistance between two exposed conductive parts of electrical protection barriers that are less than 2.5 meters from each other may be calculated using the separately measured resistances of the relevant parts of the electric path.

(b) *Test method using a DC power supply, voltmeter, and ammeter.*

(1) Connect the DC power supply, voltmeter, and ammeter to the measuring points (the electrical chassis and any exposed conductive part or any two simultaneously reachable exposed conductive parts that are less than 2.5 meters from each other) as shown in Figure 8.

(2) Adjust the voltage of the DC power supply so that the current flow becomes more than 0.2 Amperes.

(3) Measure the current  $I$  and the voltage  $V$  shown in Figure 8.

(4) Calculate the resistance  $R$  according to the formula,  $R=V/I$ .

(5) The resistance between two simultaneously reachable exposed conductive parts of electrical protection barriers that are less than 2.5 meters from each other may be calculated using the separately measured resistances of the relevant parts of the electric path.

*S7.3.3 Test method to determine voltage between exposed conductive parts of electrical protection barriers and the electrical chassis and between exposed conductive parts of electrical protection barriers.*

(a) Any parts surrounding the high voltage components are opened, disassembled, or removed without the use of tools.

(b) Connect the voltmeter to the measuring points (exposed conductive part of an electrical protection barrier and the electrical chassis or any two simultaneously reachable exposed conductive parts of electrical protection barriers that are less than 2.5 meters from each other).

(c) Measure the voltage.

(d) The voltage between two simultaneously reachable exposed conductive parts of electrical protection barriers that are less than 2.5 meters from each other may be calculated using the separately measured voltages between the relevant electrical protection barriers and the electrical chassis.

#### **S7.4 Test method for evaluating on-board electrical isolation monitoring system.**

Prior to any impact test, the requirements of S6.4 for the on-board electrical isolation monitoring system shall be tested using the following procedure.

(a) The electric energy storage device is at the state-of-charge specified in S7.1.

(b) The switch or device that provides power from the electric energy storage/conversion system to the propulsion system is in the activated position or the ready-to-drive position.

(c) Determine the isolation resistance,  $R_i$ , of the high voltage source with the electrical isolation monitoring system using the procedure outlined in S7.2.

(d) Insert a resistor with resistance  $R_o$  equal to or greater than  $1/(1/(95 \text{ times the working voltage of the high voltage source}) - 1/R_i)$  and less than  $1/(1/(100 \text{ times the working voltage of the high voltage source}) - 1/R_i)$  between the positive terminal of the high voltage source and the electrical chassis.

(e) The electrical isolation monitoring system indicator shall provide a visual warning to the driver. For a vehicle with autonomous driving systems and without manually-operated driving controls, the visual warning must be provided to all the front row occupants.

#### **S7.5 Test method for determining post-crash energy in capacitors.**

(a) Prior to the crash tests, the vehicle manufacturer must identify the capacitors, type of capacitors (x-capacitors and y-capacitors) and their respective capacitance ( $C_x$  and  $C_y$ ) in the electric power train for which the low energy compliance option for post-crash electrical safety in S8.2(d) is applied.

(b) Voltages  $V_b$ ,  $V_1$ , and  $V_2$  are measured across the capacitors in accordance with S7.1.

(c) The energy in a x-capacitor is equal to  $0.5 \times C_x \times V_b^2$

(d) The energy in a y-capacitor is equal to  $0.5 \times C_y \times (V_1^2 + V_2^2)$ .

**S8. Post-crash safety.** Each vehicle with a GVWR of 4,536 kg or less to which this standard applies, must meet the requirements in S8.1, S8.2, S8.3, and S8.4 when tested according to S9 under the conditions of S10. Each school bus with a GVWR greater than 4,536 kg to which this standard applies, must meet the requirements in S8.1, S8.2, S8.3, and S8.4 when tested according to S9.5 under the conditions of S10.

**S8.1 Fire safety.** Starting from the time of impact and continuing until one hour after the completion of the sequence of tests specified in S9 of this standard, there shall be no evidence of fire or explosion in any part of the vehicle. The assessment of fire or explosion is verified by visual inspection without disassembly of the REESS or vehicle.

**S8.2 Electrical safety.** After each test specified in S9 of this standard, each high voltage source in a vehicle must meet one of the following electrical safety requirements: electrical isolation requirements of subparagraph (a), the voltage level requirements of subparagraph (b), or the physical barrier protection requirements of subparagraph (c). High voltage capacitors in the electric power train may also meet electrical safety requirements using the low-energy requirements of subparagraph (d).

(a) The electrical isolation of the high voltage source, determined in accordance with the procedure specified in S7.2, must be greater than or equal to one of the following:

(1) 500 ohms/volt for an AC high voltage source; or

(2) 100 ohms/volt for an AC high voltage source if it is conductively connected to a DC high voltage source, but only if the AC high voltage source meets the physical barrier protection requirements specified in S8.3(c)(1) and S8.3(c)(2); or

(3) 100 ohms/volt for a DC high voltage source.

(b) The voltages  $V_1$ ,  $V_2$ , and  $V_b$  of the high voltage source, measured according to the procedure specified in S7.1, must be less than or equal to 30 VAC for AC components or 60 VDC for DC components.

(c) Protection against electric shock by direct and indirect contact (physical barrier protection) shall be demonstrated by meeting the following three conditions:

(1) The high voltage source (AC or DC) meets the protection degree IPXXB when tested according to the procedure specified in S7.3.1 using the IPXXB test probe shown in Figures 7a and 7b;

(2) The resistance between exposed conductive parts of the electrical protection barrier of the high voltage source and the electrical chassis is less than 0.1 ohms when tested according to the procedures specified in S7.3.2. In addition, the resistance between an exposed conductive part of the electrical protection barrier of the high voltage source and any other simultaneously reachable exposed conductive parts of electrical protection barriers within 2.5 meters of it must be less than 0.2 ohms when tested using the test procedures specified in S7.3.2; and

(3) The voltage between exposed conductive parts of the electrical protection barrier of the high voltage source and the electrical chassis is less than or equal to 30 VAC or 60 VDC as measured in accordance with S7.3.3. In addition, the voltage between an exposed conductive part of the electrical protection barrier of the high voltage source and any other simultaneously reachable exposed conductive parts of electrical protection barriers within 2.5 meters of it must be less than or equal to 30 VAC or 60 VDC as measured in accordance with S7.3.3.

(d) The total energy of unidirectional single impulse currents from capacitors shall be less than 0.2 Joules when determined in accordance with the procedure specified in S7.5.

**S8.3 Electric energy storage/conversion device retention.** During and after each test specified in S9 of this standard:

(a) Electric energy storage/conversion devices shall remain attached to the vehicle by at least one component anchorage, bracket, or any structure that transfers loads from the device to the vehicle structure, and

(b) Electric energy storage/conversion devices located outside the occupant compartment shall not enter the occupant compartment.

**S8.4 Electrolyte leakage from electric energy storage devices.** Not more than 5.0 liters of electrolyte shall leak from electric energy storage devices, and no visible trace of electrolyte shall leak into the passenger compartment. Leakage is measured from the time of the impact until 30 minutes thereafter, and throughout any static rollover after a barrier impact test, specified in S9 of this standard.

**S9. Crash test specifications.** A test vehicle with a GVWR less than or equal to 4,536 kg, under the conditions of S10, is subject to any one single barrier crash test of S9.1, S9.2, or S9.3, followed by the static rollover test of S9.4. A school bus with a GVWR greater than 4,536 kg, under the conditions of S10, is subject to the contoured barrier crash test of S9.5. A particular vehicle need not meet further test requirements after having been subjected to a single barrier crash/static rollover test sequence.

**S9.1 Frontal barrier crash.** The test vehicle, with test dummies in accordance with S6.1 of 571.301 of this chapter, traveling longitudinally forward at any speed up to and including 48 km/h, impacts a fixed collision barrier that is perpendicular to the line of travel of the vehicle, or at an angle up to 30 degrees in either direction from the perpendicular to the line of travel of the vehicle.

**S9.2 Rear moving barrier impact.** The test vehicle, with test dummies in accordance with S6.1 of 571.301 of this chapter, is impacted from the rear by a barrier that conforms to S7.3(b) of 571.301 of this chapter and that is moving at any speed between 79 and 81 km/h.

**S9.3 Side moving deformable barrier impact.** The test vehicle, with the appropriate 49 CFR Part 572 test dummies specified in 571.214 at positions required for testing by S7.1.1, S7.2.1, or S7.2.2 of Standard 214, is impacted laterally on either side by a moving deformable barrier moving at any speed between 52.0 km/h and 54.0 km/h.

**S9.4 Post-impact test static rollover.** After each crash test specified in S9.1, S9.2, and S9.3, without any alteration of the vehicle, the vehicle is rotated on its longitudinal axis to each successive increment of 90 degrees under the test conditions of S10.3.

**S9.5 Moving contoured barrier crash.** The test vehicle, under the conditions of S10.1 and S10.2, is impacted at any point and at any angle by the moving contoured barrier assembly, specified in S7.5 and S7.6 in 571.301 of this chapter, traveling longitudinally forward at any speed up to and including 48 km/h.

#### **S10. Crash test conditions.**

**S10.1 State-of-charge.** The electric energy storage device(s) shall be at the state-of-charge specified in either subparagraph (a), (b), or (c):

(a) At the maximum state-of-charge in accordance with the vehicle manufacturer's recommended charging procedures, as stated in the vehicle owner's manual or on a label that is permanently affixed to the vehicle; or

(b) If the manufacturer has made no recommendation for charging procedures in the owner's manual or on a label permanently affixed to the vehicle, at a state-of-charge of not less than 95 percent of the maximum capacity of the electric energy storage device(s); or

(c) If the electric energy storage device(s) is/are rechargeable only by an energy source on the vehicle, at any state-of-charge within the normal operating voltage defined by the vehicle manufacturer.

**S10.2 Vehicle conditions.** The switch or device that provides power from the electric energy storage/conversion system to the propulsion system is in the activated position or the

ready-to-drive position. Bypass any devices or systems that do not allow the propulsion system to be energized at the time of impact when the vehicle ignition is on and the vehicle is in neutral.

S10.2.1 The parking brake is disengaged and the vehicle drive system is in the neutral position. In a test conducted under S9.3, the parking brake is set.

S10.2.2 Tires are inflated to the manufacturer's specifications.

S10.2.3 The vehicle, including test devices and instrumentation, is loaded as follows:

(a) A passenger car is loaded to its unloaded vehicle weight plus its rated cargo and luggage capacity weight, secured in the luggage compartment, plus the necessary test dummies as specified in S9, restrained only by means that are installed in the vehicle for protection at its seating position.

(b) A multipurpose passenger vehicle, truck, or bus, with a GVWR of 4,536 kg (10,000 lb) or less, is loaded to its unloaded vehicle weight plus the necessary dummies, as specified in S9, plus 136 kg or its rated GVWR, whichever is less, secured in the load carrying area and distributed as nearly as possible in proportion to its GVWR. For the purpose of this standard, unloaded vehicle weight does not include the weight of work-performing accessories. Each dummy is restrained only by means that are installed in the vehicle for protection at its seating position.

S10.3 ***Static rollover test conditions.*** The vehicle is rotated about its longitudinal axis, with the axis kept horizontal, to each successive increment of 90°, 180°, and 270° at a uniform rate, with 90° of rotation taking place in any time interval from 1 to 3 minutes. After reaching each 90° increment the vehicle is held in that position for 5 minutes.

S10.4 ***Rear moving barrier impact test conditions.*** The conditions of S7.3(b) and S7.6 of 571.301 of this chapter apply to the conducting of the rear moving deformable barrier impact test specified in S9.2.

S10.5 *Side moving deformable barrier impact test conditions.* The conditions of S8.9, S8.10, and S8.11 of 571.214 of this chapter apply to the conduct of the side moving deformable barrier impact test specified in S9.3.

**S11. Vehicle controls managing REESS safe operations.** Each vehicle to which the standard applies shall meet the requirements in S11.1, S11.2, and S11.3, when tested according to S12.

S11.1 When tested in accordance with the overcharge test in S12.1, the over-discharge test in S12.2, the overcurrent test in S12.3, the high-temperature test in S12.4, and the short-circuit test in accordance with S12.5, each vehicle shall meet the following:

(a) During the test, there shall be no evidence of electrolyte leakage, rupture, venting, fire, or explosion of the REESS as verified by visual inspection without disassembly of the vehicle.

(b) The isolation resistance of the high voltage sources measured after the test shall not be less than 100 ohms/volt when determined in accordance with S7.2.

S11.2 The vehicle manufacturer must make available to the agency, upon request, documentation in accordance with S12.7 that demonstrates whether the vehicle is equipped with controls for REESS operations at or below the lower boundary REESS temperature threshold for safe REESS operations specified by the manufacturer.

S11.3 The vehicle manufacturer must make available to the agency, upon request, documentation in accordance with S12.8 that demonstrates the activation of a visual warning, when the vehicle is in active driving possible mode to indicate operational failure of the vehicle controls that manage the safe operation of the REESS. The warning system shall monitor its own readiness and the visual warning must be provided to the driver. For a vehicle with autonomous driving systems and without manually operated driving controls, the visual warning must be provided to all the front row occupants.

**S12. Test methods and documentation for evaluating vehicle controls managing REESS safe operations.**

**S12.1 Overcharge test.** The overcharge test is conducted at ambient temperatures between 10 °C and 30 °C, with the vehicle REESS initially set between 90 to 95 percent SOC. The following steps are conducted to evaluate the vehicle's overcharge protection controls:

(a) A breakout harness is connected to the traction side of the REESS. Manufacturer may specify an appropriate location(s) and attachment point(s) to connect the breakout harness.

(b) Temperature probes are connected to the REESS outer casing to monitor changes in REESS temperature. Temperature measurements may also be obtained through communication with the REESS control module.

(c) The external charge/discharge equipment, with maximum voltage and current set at least 10 percent higher than the REESS voltage and current limits, is connected to the breakout harness.

(d) The vehicle switch or device that provides power to the vehicle controls that manage REESS operations is set to the activated position.

(e) The REESS is charged with the external charge/discharge equipment with the maximum charge current specified by the manufacturer. If the manufacturer does not specify an appropriate charge current, then a charge rate of  $\frac{1}{3}C$  is used.

(f) Charging is continued until the following occurs:

(1) The overcharge protection control terminates the charge current;

(2) The REESS temperature is 10 °C above the manufacturer specified maximum operating temperature of the REESS; or

(3) 12 hours have passed since the start of charging the vehicle.

(g) After the charge current is terminated, if charge and discharge is permitted by the vehicle controls, a standard cycle is performed in accordance with S12.6.

(h) After the completion of the standard cycle, or if the standard cycle was not performed, after charging is terminated, the vehicle is observed for 1 hour for evidence of electrolyte leakage, rupture, venting, fire, or explosion of the REESS.

(i) At the conclusion of the test, electrical isolation of the REESS is determined in accordance with S7.2.

**S12.2 Over-discharge test.** The over-discharge test is conducted at ambient temperatures between 10 °C and 30 °C, with the vehicle REESS initially set between 10 and 15 percent SOC. For a vehicle with on-board energy conversion systems such as an internal combustion engine or a fuel cell, the fuel supply is set to the minimum level where active driving possible mode is permitted. The following steps are conducted to evaluate the vehicle's over-discharge protection controls:

(a) A breakout harness is connected to the traction side of the REESS. Manufacturer may specify an appropriate location(s) and attachment point(s) to connect the breakout harness.

(b) Temperature probes are connected to the REESS outer casing to monitor changes in REESS temperature. Temperature measurements may also be obtained through communication with the REESS control module.

(c) The external charge/discharge equipment, with maximum voltage and current set at least 10 percent higher than the REESS voltage and current limits, is connected to the breakout harness.

(d) The vehicle switch or device that provides power from the REESS to the electric power train is set to the activated position or the active driving possible mode.

(e) The REESS is discharged with the external charge/discharge equipment with the maximum discharge rate under normal operating conditions specified by the manufacturer. If the manufacturer does not specify an appropriate discharge rate, a power load of 1kW is used.

(f) Discharging is continued until the following occurs:

(1) The over-discharge protection control terminates the discharge current;

(2) The temperature gradient of the REESS is less than 4 °C through 2 hours from the start of discharge; or

(3) the vehicle is discharged to 25 percent of its nominal voltage level.

(g) After the discharge current is terminated, a standard cycle is performed in accordance with S12.6, if charge and discharge is permitted by the vehicle controls.

(h) After the completion of the standard cycle, or if the standard cycle was not performed, after discharging is terminated, the vehicle is observed for 1 hour for evidence of electrolyte leakage, rupture, venting, fire, or explosion of the REESS.

(i) At the conclusion of the test, electrical isolation of the REESS is determined in accordance with S7.2.

**S12.3 Overcurrent test.** The overcurrent test is only conducted on vehicles that have the capability of charging by DC external electricity supply. The test is conducted at ambient temperatures between 10 °C and 30 °C, with the vehicle REESS initially set between 40 to 50 percent SOC. The following steps are conducted to evaluate the vehicle's over-current protection controls:

(a) A breakout harness is connected to the traction side of the REESS. Manufacturer may specify an appropriate location(s) and attachment point(s) to connect the breakout harness.

(b) Temperature probes are connected to the REESS outer casing to monitor changes in REESS temperature. Temperature measurements may also be obtained through communication with the REESS control module.

(c) The external charge/discharge equipment, with maximum voltage and current set at least 10 percent higher than the REESS voltage and current limits, is connected to the breakout harness.

(d) The vehicle switch or device that provides power to the vehicle controls that manage REESS operations is set to the activated position.

(e) The REESS is charged with the external charge/discharge equipment with the maximum charge current specified by the manufacturer. If the manufacturer does not specify an appropriate charge current, then a charge rate of  $\frac{1}{3}C$  is used.

(f) After charging is initiated, the overcurrent specified by the manufacturer is supplied over the course of 5 seconds from the maximum charge current level to the over-current level. If the vehicle manufacturer does not supply an overcurrent level, a 10 Ampere over-current is supplied over 5 seconds. If charging is not terminated, the over-current supply is increased in steps of 10 Amperes.

(g) Charging at the over-current level is continued until the following occurs:

(1) The over-current protection control terminates the charge current; or

(2) The temperature gradient of the REESS is less than 4 °C through 2 hours from the first overcurrent input;

(h) After the charge current is terminated, if charge and discharge is permitted by the vehicle controls, a standard cycle is performed in accordance with S12.6.

(i) After the completion of the standard cycle or if the standard cycle was not performed, after charging is terminated, the vehicle is observed for 1 hour for evidence of electrolyte leakage, rupture, venting, fire, or explosion of the REESS.

(j) At the conclusion of the test, electrical isolation of the REESS is determined in accordance with S7.2.

**S12.4 Over-temperature test.** The overtemperature test is conducted at ambient temperatures between 10 °C and 30 °C on a chassis-dynamometer with the vehicle REESS initially set between 90 to 95 percent SOC. For a vehicle with on-board energy conversion systems such as an internal combustion engine or a fuel cell, the fuel supply is set to allow operation for about one hour of driving. The following steps are conducted to evaluate the vehicle's high temperature protection controls:

(a) The cooling system of the REESS is disabled using manufacturer supplied information. For an REESS that will not operate if the cooling system is disabled, the cooling operation is significantly reduced. If manufacturer does not supply information to disable or significantly reduce the cooling system, methods such as crimping the liquid cooling hose, removing refrigerant fluid, or blocking cabin air intakes for air cooled REESS are applied.

(b) Temperature probes are connected to the REESS outer casing to monitor changes in REESS temperature. Temperature measurements may also be obtained through communication with the REESS control module.

(c) The vehicle is installed on a chassis dynamometer and the vehicle switch or device that provides power from the REESS to the electric power train is set to the activated position or the active driving possible mode.

(d) The vehicle is driven on the dynamometer using an appropriate vehicle manufacturer supplied drive profile and charging information for discharge and charge of the REESS to raise the REESS temperature to its upper boundary safe operating temperature within one hour. If an appropriate manufacturer supplied drive profile is not available, the vehicle is repeatedly accelerated to 80 mph and then decelerated to 15 mph within 40 seconds. If the manufacturer does not supply a charge profile, then a charge rate greater than  $\frac{1}{3}C$  current is used.

(e) The discharge/charge procedure on the chassis-dynamometer is continued until the following occurs:

(1) The vehicle terminates the discharge/charge cycle;

(2) The temperature gradient of the REESS is less than 4 °C through 2 hours from the start of the discharge/charge cycle; or

(3) 3 hours have passed since the start of discharge/charge cycles.

(g) After the discharge and charge procedure is terminated, if charge and discharge is permitted by the vehicle controls, a standard cycle is performed in accordance with S12.6.

(h) After the completion of the standard cycle, or if the standard cycle is not performed, after the discharge and charge procedure is terminated, the vehicle is observed for 1 hour for evidence of electrolyte leakage, rupture, venting, fire, or explosion of the REESS.

(i) At the conclusion of the test, electrical isolation of the REESS is determined in accordance with S7.2.

**S12.5 External Short circuit test.** The short circuit test is conducted at ambient conditions with the vehicle REESS initially set between 90 to 95 percent SOC. The following steps are conducted to evaluate the vehicle's overcharge protection controls:

(a) A breakout harness is connected to the REESS. Manufacturer may specify an appropriate location(s) and attachment point(s) to connect the breakout harness.

(b) Temperature probes are connected to the REESS outer casing to monitor changes in REESS temperature. Temperature measurements may also be obtained through communication with the REESS control module.

(c) The vehicle switch or device that provides power to the vehicle controls that manage REESS operations is set to the activated position.

(d) The short circuit contactor (with the contactors in open position) is connected to the breakout harnesses. The total resistance of the equipment to create the external short circuit (short circuit contactor and breakout harnesses) is verified to be between 2 to 5 milliohms.

(e) The short circuit contactor is closed to initiate the short-circuit.

(f) The short circuit condition is continued until the following occurs:

(1) Short circuit current is terminated; or

(2) The temperature gradient of the REESS is less than 4 °C through 2 hours from the start of initiating the short circuit condition.

(g) After the short circuit current is terminated, if charge and discharge is permitted by the vehicle controls, a standard cycle is performed in accordance with S12.6.

(h) After the completion of the standard cycle, or if the standard cycle was not performed, after short circuit current is terminated, the vehicle is observed for 1 hour for evidence of electrolyte leakage, rupture, venting, fire, or explosion of the REESS.

(i) At the conclusion of the test, electrical isolation of the REESS is determined in accordance with S7.2.

**S12.6 Standard cycle.** The standard cycle is conducted at ambient temperatures between 10 °C and 30 °C and starts with a standard discharge followed by a standard charge. The discharge and charge procedures would follow manufacturer supplied information. The charge procedure is initiated 15 minutes after discharge is terminated.

(a) If the manufacturer does not provide a discharge procedure, the vehicle is discharged with 1C current until discharge is terminated by vehicle controls.

(b) If the manufacturer does not provide a charge procedure, the vehicle is charged with  $\frac{1}{3}$ C current until terminated by vehicle controls.

**S12.7 Documentation for low temperature operation safety.** At NHTSA's request, each manufacturer shall submit documentation that includes the following:

(a) The make, model, model year, and production dates of the vehicles to which the submitted documentation applies.

(b) The lower temperature boundary for safe REESS operation in all vehicle operating modes.

(c) A description and explanation of charge and discharge rates at the lower temperature boundary for safe REESS operation.

(d) A description of the method used to detect REESS temperature.

(e) A system diagram with key components and subsystems involved in maintaining safe REESS charging and discharging operation for temperatures at or below the lower temperature boundary for safe REESS operation.

(f) A description of how the vehicle controls, ancillary equipment, and design features were validated and verified for maintaining safe REESS operations at or below the lower temperature boundary for safe REESS operation.

(g) Overall evaluation: A description of the final manufacturer review/audit process and results of any final review or audit evaluating the technical content and the completeness and verity of S12.7(a) to S12.7(f).

**S12.8 Documentation and visual warning in the event of operational failure of vehicle controls.**

(a) During the vehicle's active driving mode, the vehicle shall provide a visual warning to the driver when there is a vehicle control malfunction.

(b) At NHTSA's request, each manufacturer shall submit documentation that includes the following:

(1) The make, model, model year, and production dates of the vehicles to which the submitted documentation applies.

(2) A system diagram that identifies all the vehicle controls that manage REESS operation. The diagram must identify what components are used to generate a visual warning indicating malfunction of vehicle controls to conduct one or more basic operations.

(3) A written explanation describing the basic operation of the vehicle controls that manage REESS operation. The explanation must identify the components of the vehicle control system, provide description of their functions and capability to manage the REESS, and provide a logic diagram and description of conditions that would lead to triggering the telltale activation.

(4) Validation results from tests to confirm the display of a visual warning in the presence of a malfunction of the vehicle controls which manage safe operation of the REESS.

(5) Overall evaluation: A description of the final manufacturer review/audit process and results of the final review or audit which evaluated the technical content and the completeness and verity of S12.8(b)(1) to S12.8(b)(4).

### **S13. REESS thermal propagation safety.**

**S13.1 Thermal runaway due to internal short in a single cell of the REESS.** The vehicle manufacturer shall make available to the agency, upon request, documentation demonstrating how the vehicle and its REESS are designed to mitigate the safety risks associated with thermal propagation resulting from a single cell thermal runaway due to an internal short within the cell. The documentation shall demonstrate thermal propagation safety risk mitigation for the vehicle in external charging mode, active driving possible mode, and parking mode. The documentation shall include the following:

(a) The make, model, model year, and production dates of the vehicles to which the submitted documentation applies.

(b) Part I: System analysis. This part of the documentation shall identify the conditions which could lead to single-cell thermal runaway due to an internal short-circuit in different vehicle operational modes and allocate applicable functional units, components, subsystems to each identified condition. This part shall include:

(1) A system diagram and a description of all relevant physical systems and components of the REESS, including information about the cell type and electrical configuration, cell chemistry, electrical capacity, voltage, current limits during charging and discharging, thermal limits of the components that are critical for thermal propagation safety.

(2) A system diagram, operational description of sensors, components, functional units relevant to single-cell thermal runaway due to internal short-circuit and thermal propagation, and the interrelationship between the identified sensors, components, and functional units;

(3) A description of conditions under which a single-cell thermal runaway and propagation event due to an internal short-circuit could occur;

(4) A description of how the identified conditions were allocated to each identified component, functional unit, and subsystem;

(5) A description of the process used to review the identified conditions and their allocation to the identified sensors, components, and functional units, for completeness and validity; and

(6) A description of the warning or notification system before the thermal runaway occurred, including a description of the detection technology and mitigation strategies, if any.

(c) Part II: Safety risk assessment and mitigation process. This part of the documentation shall identify thermal propagation safety risk mitigation strategies for identified conditions leading to single cell thermal runaway in Part I and include:

(1) A description of the safety risks and safety risk mitigation strategies, and how these were identified, and

(2) A description of how each risk mitigation strategy manages, mitigates, or prevents the identified safety risks.

(3) Safety risk mitigation strategies identified should include those that mitigate the risk of single cell thermal runaway due to an internal short and mitigate the occurrence of thermal propagation due to single-cell thermal runaway resulting from an internal short-circuit within the cell.

(d) Part III: Verification and validation of risk mitigation strategies. This part of the documentation pertains to verification that the manufacturer identified safety risks and considered safety risk mitigation strategies and include:

(1) A description of how each risk mitigation strategy was verified and validated for effectiveness,

(2) A description of the verification and validation results for each risk mitigation strategy, and

(3) A description of and results from the vehicle level assessment.

(e) Part IV: Overall evaluation of risk mitigation. This part of the documentation summarizes the vehicle design and manufacturing strategies and their validation to mitigate the

safety risks associated with thermal propagation due single cell thermal runaway resulting from internal short within a cell. This part shall include a description of the final manufacturer review/audit process and results of the final review or audit evaluating the technical content and the completeness and verity of S13.1(a) to S13.1(d).

**S13.2 Warning in the case of thermal event in REESS.** The vehicle shall provide a warning to the driver of a thermal event in the REESS. The warning shall activate within three minutes of activating a heater within the REESS when tested in accordance with S13.3. The warning shall consist of auditory and visual signals that remain active for at least 5 minutes. The thermal event warning system must monitor its own readiness and the warning must be provided to the driver.

**S13.3 Test procedure for evaluating warning for thermal event in REESS.** The thermal event warning test is conducted at ambient temperatures between 10 °C and 30 °C with the vehicle REESS initially set between 90 to 95 percent SOC. The following steps are conducted to evaluate the warning in the case of thermal event in the REESS:

- (a) If possible, the REESS is removed from the vehicle.
- (b) The REESS casing is opened.
- (c) A heater that achieves a peak temperature of 600 °C within 30 seconds is attached to one or more cells in the REESS in a manner to put at least one cell in the REESS into thermal runaway.
- (d) The REESS casing is closed and the REESS is reinstalled into the vehicle (if initially removed in (a)).
- (e) Vehicle stops to prevent vehicle rollaway are installed.
- (f) The vehicle is placed in active driving possible mode.
- (g) The heater within the REESS is activated to achieve 600 °C within 30 seconds. The heater shall remain operational until thermal runaway is initiated in at least one cell.

(h) The time for the activation of the warning to the front row occupant (if any) from the time of activation of the heater is noted.

(i) The test is terminated after activation of the warning or after four minutes of activating the heater in the REESS, whichever comes first.

**S14. Water exposure safety.** Each vehicle to which the standard applies shall maintain electrical isolation as specified in S6.3.1 and S6.3.2 at these times: (a) just after exposure to water in each of the two tests specified below and with the vehicle still wet; and (b) after a minimum of 24 hours after completing each of the tests specified below.

*S14.1 Vehicle washing test.* The vehicle is sprayed from any direction with a stream of freshwater from a standard test nozzle shown in Figure 9 that has a nozzle internal diameter of 6.3 millimeters, delivery rate of 11.9 to 13.2 liters/minute, and water pressure at the nozzle between 30 kPa to 35 kPa.

(a) During the washing, the distance from the nozzle to the vehicle surface is 3.0 to 3.2 meters. The distance of the nozzle from the vehicle surface may be reduced, if necessary, to ensure the surface is wet when spraying upwards. The washing test duration per square meter of the vehicle surface area is 60 to 75 seconds, with a minimum total test duration of 3 minutes.

(b) The vehicle external surface, including the vehicle sides, front, rear, top, and bottom is exposed to the water stream. Border lines on the vehicle such glass seals, outline of opening parts (doors, windows, vehicle inlet cover), outline of front grille, seals of vehicle lamps are exposed to the water stream from any direction.

(c) At the conclusion of the normal washing test, with the vehicle still wet, electrical isolation is determined in accordance with S7.2.

*S14.2 Driving through standing water test.* The vehicle is driven through a wade pool of at least 10 centimeters but not more than 15 centimeters depth of freshwater for a distance of 500 meters at a minimum speed of 12 mph (20 km/h) but not more than 15 mph (24 km/h).

(a) If the wade pool is less than 500 m in length, then the vehicle shall be driven through it several times for a total distance of 500 m. The total time, including the period outside of the wade pool, shall be less than 5 minutes.

(b) At the conclusion of the standing water test, with the vehicle still wet, electrical isolation is determined in accordance with S7.2.

## **S15. Rescue Sheets and Emergency Response Guides.**

**S15.1 Rescue Sheets.** Prior to vehicle certification per 49 CFR part 567, vehicle manufacturers shall submit rescue sheets to NHTSA.

(a) For vehicles with a GVWR less than or equal to 4,536 kg to which the standard applies, submitted rescue sheets shall follow the layout and format in ISO-17840-1:2022(E).

(b) For vehicles with a GVWR greater than 4,536 kg to which the standard applies, the submitted rescue sheets shall follow the layout and format in ISO-17840-2:2019(E).

(c) The rescue sheets shall provide information for first responders to extricate occupants.

**S15.2 Emergency Response Guides.** Prior to vehicle certification per 49 CFR part 567, vehicle manufacturers shall submit to NHTSA Emergency Response Guides (ERGs) in accordance with the template layout and format in ISO-17840-3:2019(E) for vehicles to which this standard applies.

(a) The ERGs shall provide in-depth information linked and aligned to the corresponding rescue sheet to support the quick and safe action of first responders and second responders.

(b) The ERGs shall provide in-depth information related to electric vehicle fire, submersion, leakage of fluids, towing, transportation, and storage.

(c) The ERGs shall provide information to assist first responders in extricating occupants.

Figures to FMVSS No. 305a.

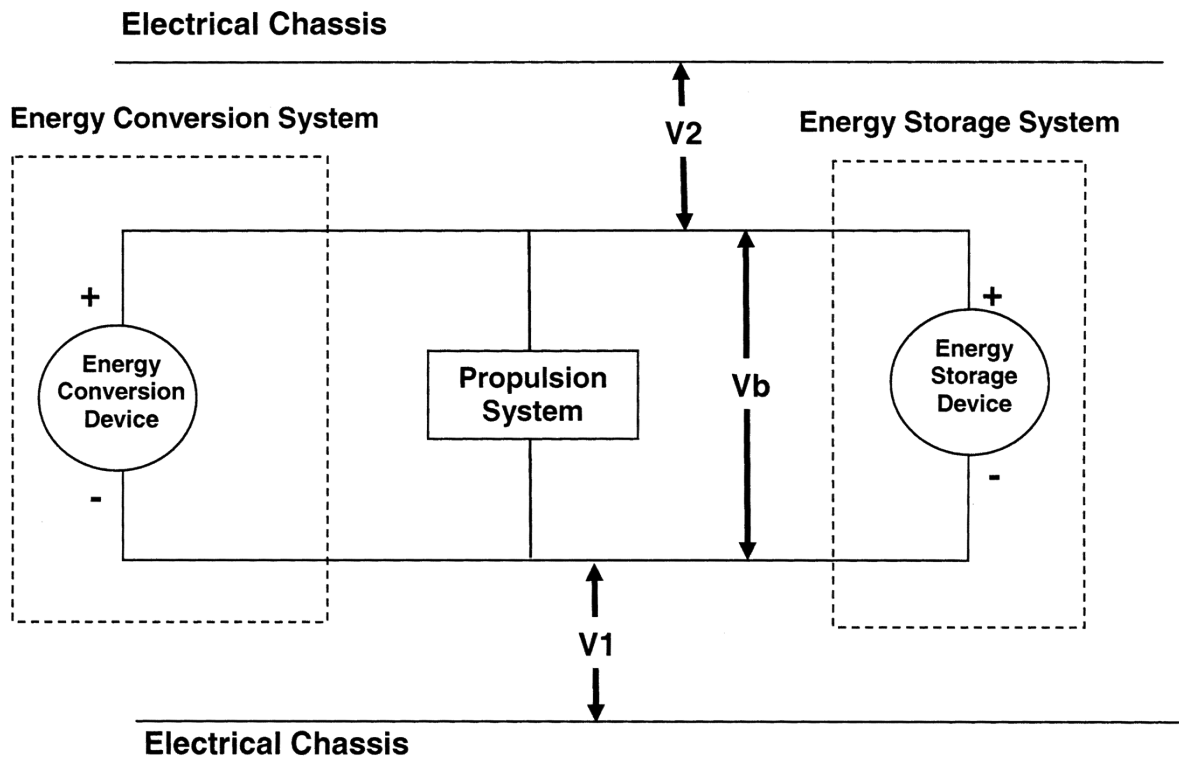

Figure 1. Voltage Measurements of the High Voltage Source.

## Electrical Chassis

---

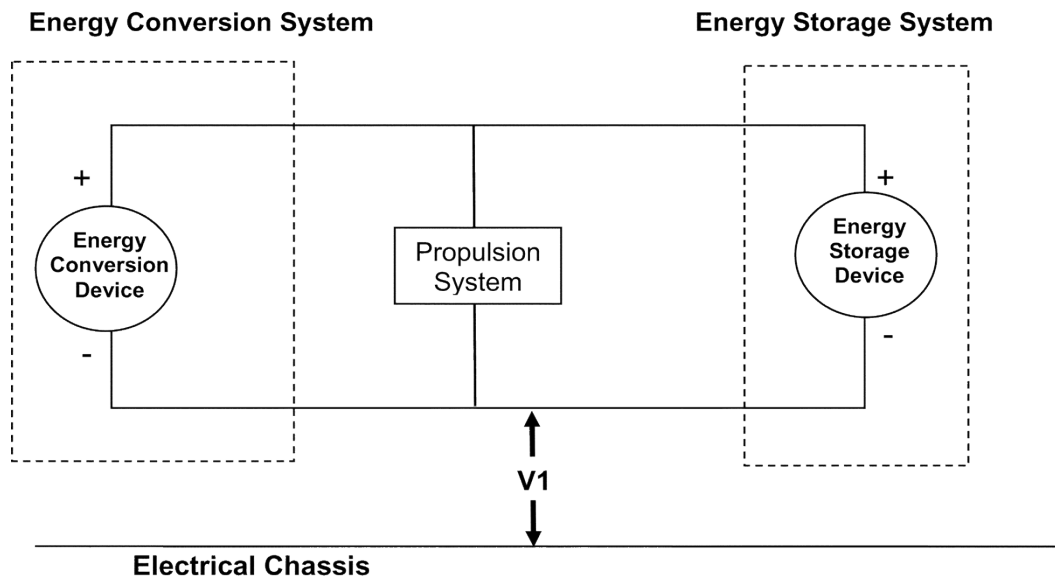

Figure 2. Measurement for V1 Voltage between the Negative Side of the High Voltage Source and the Electrical Chassis

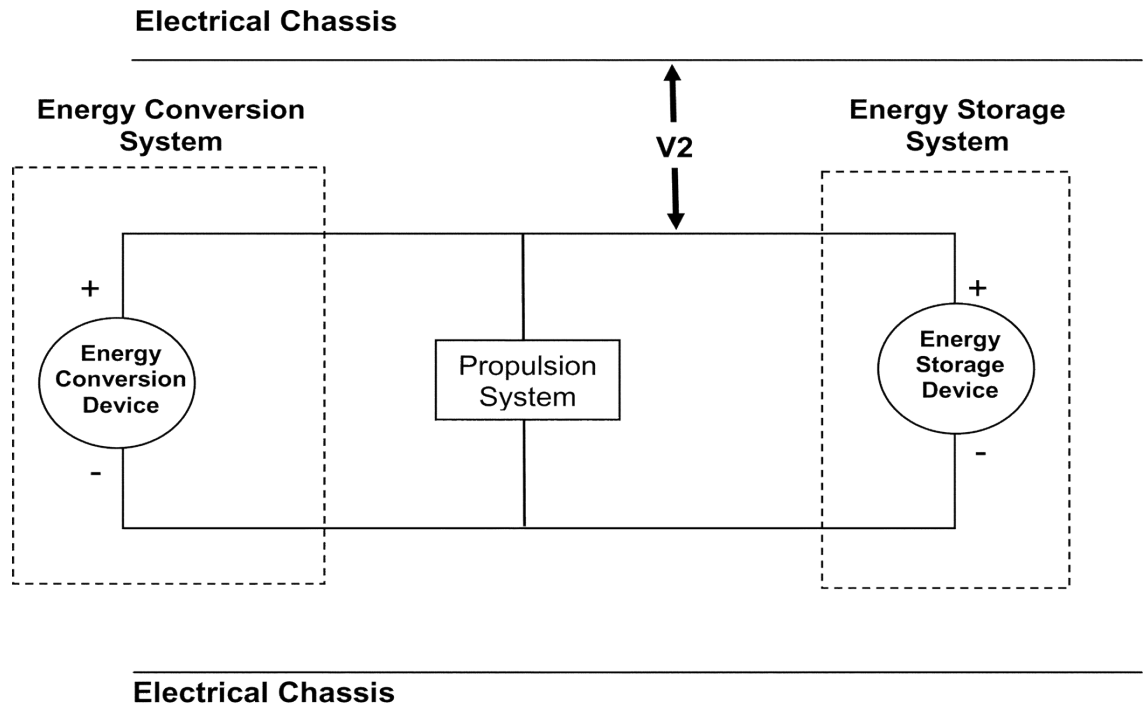

Figure 3. Measurement for V2 Voltage between the Positive Side of the High Voltage Source and the Electrical Chassis

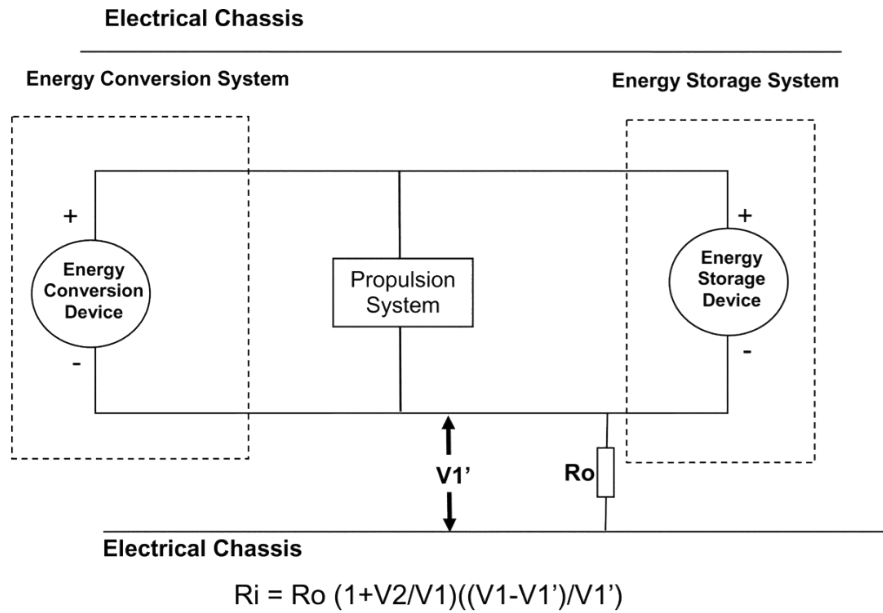

Figure 4. Measurement for  $V_1'$  Voltage Across Resistor between Negative Side of the High Voltage Source and Electrical Chassis.

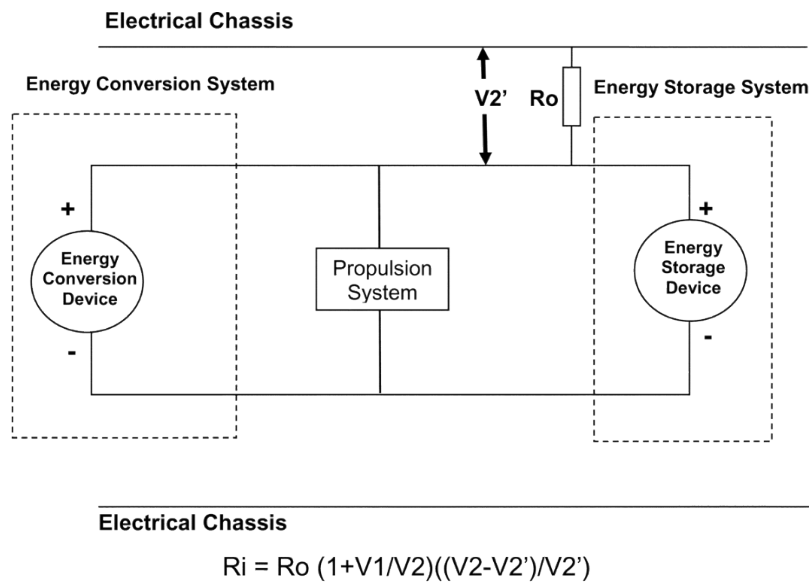

Figure 5. Measurement for  $V_2'$  Voltage Across Resistor between Positive Side of the High Voltage Source and Electrical Chassis.

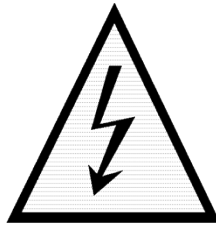

Figure 6. Marking of High Voltage Sources.

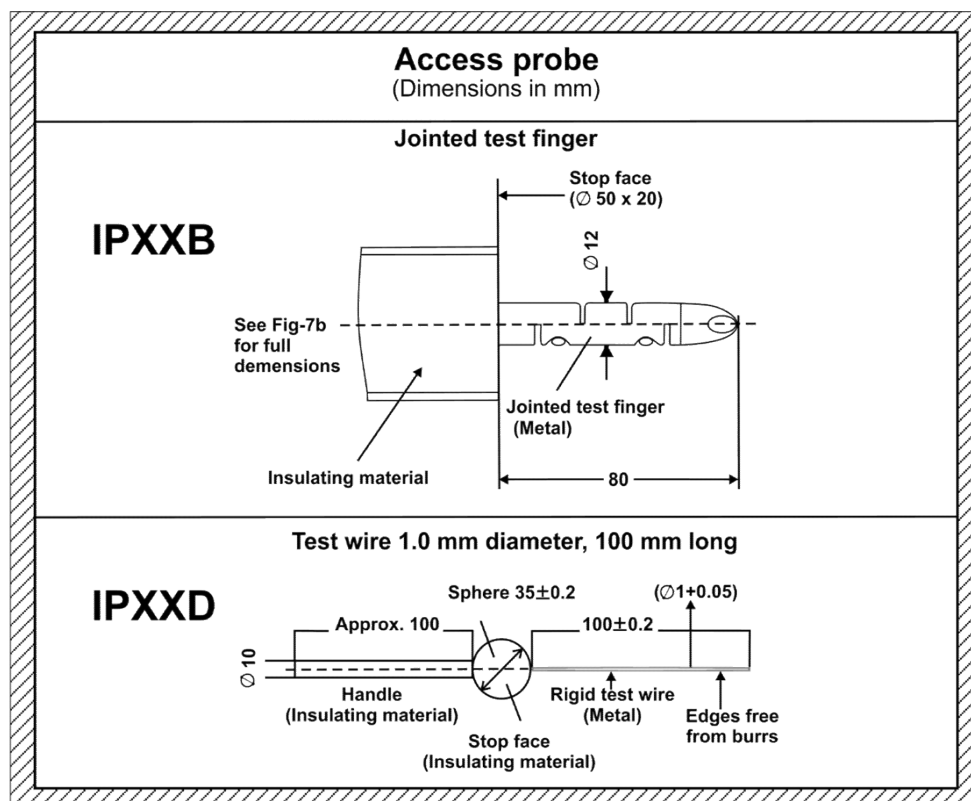

Figure 7a. Access Probes for the Tests of Direct Contact Protection. Access Probe IPXXB (top)

and Access Probe IPXXD (bottom)



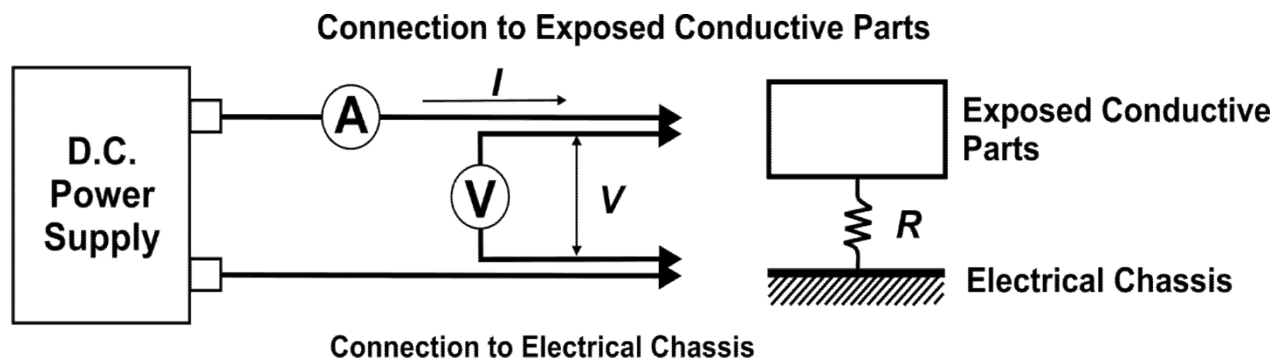
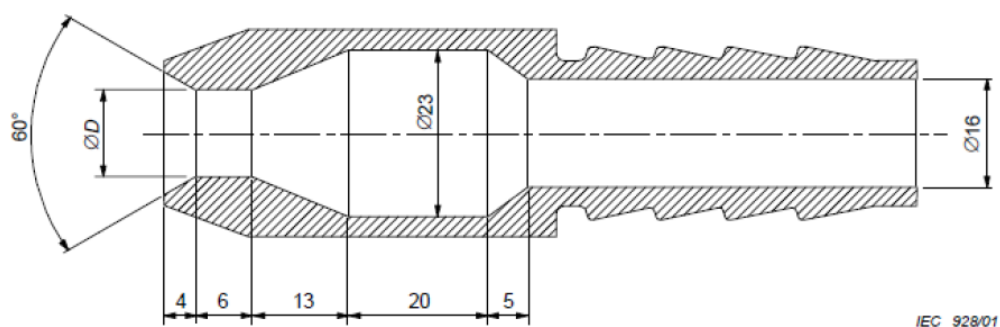

Figure 8. Connection to Determine Resistance between Exposed Conductive Parts of Electrical Protection Barrier and Electrical Chassis.



Dimensions in millimetres  
*D* is 6.3 mm as specified in (a) above.

Figure 9. Standard Nozzle for IPX5 Water Exposure Test

Issued in Washington, D.C., under authority delegated in 49 CFR 1.95 and 501.5.

---

Sophie Shulman,

Deputy Administrator

Billing Code 4910-59-P

[FR Doc. 2024-07646 Filed: 4/12/2024 8:45 am; Publication Date: 4/15/2024]