



ENVIRONMENTAL PROTECTION AGENCY

40 CFR Part 63

[EPA-HQ-OAR-2022-0491; FRL-9992-01-OAR]

RIN 2060-AV81

EPA Method 320 – Measurement of Vapor Phase Organic and Inorganic Emissions by Extractive Fourier Transform Infrared (FTIR) Spectroscopy

AGENCY: Environmental Protection Agency (EPA).

ACTION: Proposed rule.

SUMMARY: This action proposes editorial and technical revisions to the Environmental Protection Agency's (EPA's) Method 320 (Measurement of Vapor Phase Organic and Inorganic Emissions by Extractive Fourier Transform Infrared (FTIR) Spectroscopy). The proposed revisions include updating the validation and quality assurance (QA) spiking procedures of the method to provide a more performance-based approach with specified acceptance criteria. The proposed revisions will provide flexibility to the stack testing community while ensuring consistent implementation and quality of the measurement results across emissions sources and facilities.

DATES: *Comments.* Comments must be received on or before **[INSERT DATE 60 DAYS AFTER DATE OF PUBLICATION IN THE FEDERAL REGISTER]**.

Public Hearing. The EPA will hold a virtual public hearing on **[INSERT DATE 28 DAYS AFTER DATE OF PUBLICATION IN THE FEDERAL REGISTER]** if a request for a virtual public hearing is received on or before **[INSERT DATE 7 DAYS AFTER DATE OF PUBLICATION IN THE FEDERAL REGISTER]**. Refer to the **SUPPLEMENTARY INFORMATION** section for additional information on the virtual public hearing.

ADDRESSES: You may submit comments, identified by Docket ID No. EPA-HQ-OAR-2022-0491, by any of the following methods:

- Federal eRulemaking Portal: <https://www.regulations.gov/> (our preferred method).
Follow the online instructions for submitting comments.
- Email: a-and-r-docket@epa.gov. Include Docket ID No. EPA-HQ-OAR-2022-0491 in the subject line of the message.
- Fax: (202) 566-9744. Attention Docket ID No. EPA-HQ-OAR-2022-0491.
- Mail: U.S. Environmental Protection Agency, EPA Docket Center, Docket ID No. EPA-HQ-OAR-2022-0491, Mail Code 28221T, 1200 Pennsylvania Avenue, NW, Washington, DC 20460.
- *Hand/Courier Delivery*: EPA Docket Center, WJC West Building, Room 3334, 1301 Constitution Avenue, NW, Washington, DC 20004. The Docket Center’s hours of operation are 8:30 a.m. – 4:30 p.m., Monday – Friday (except Federal Holidays).

Instructions: All submissions received must include the Docket ID No. for this rulemaking. Comments received may be posted without change to <https://www.regulations.gov/>, including any personal information provided. For detailed instructions on sending comments and additional information on the rulemaking process, see the “Public Participation” heading of the **SUPPLEMENTARY INFORMATION** section of this document.

FOR FURTHER INFORMATION CONTACT: Dr. David Nash, Office of Air Quality Planning and Standards, Air Quality Assessment Division (E143-02), Environmental Protection Agency, Research Triangle Park, NC 27711; telephone number: (919) 541-9425; fax number: (919) 541-0516; e-mail address: nash.dave@epa.gov.

SUPPLEMENTARY INFORMATION:

Preamble acronyms and abbreviations. Throughout this document, the use of “we,” “us,” or “our” is intended to refer to the EPA. We use multiple acronyms and terms in this preamble. While this list may not be exhaustive, to ease the reading of this preamble and for reference purposes, the EPA defines the following terms and acronyms here:

ASTM American Society for Testing and Materials

CAA	Clean Air Act
CBI	Confidential Business Information
CFR	Code of Federal Regulations
CTS	calibration transfer standard
EPA	Environmental Protection Agency
FTIR	Fourier Transform Infrared
FTP	File Transfer Protocol
IR	infrared
NAICS	North American Industry Classification System
NESHAP	National Emissions Standards for Hazardous Air Pollutants
NIST	National Institute of Standards and Technology
NSPS	New Source Performance Standards
NTTAA	National Technology Transfer and Advancement Act
OAQPS	Office of Air Quality Planning and Standards
OMB	Office of Management and Budget
PRA	Paperwork Reduction Act
PTFE	polytetrafluoroethane
QA	quality assurance
RFA	Regulatory Flexibility Act
SF ₆	sulfur hexafluoride
TTN	Technology Transfer Network
UMRA	Unfunded Mandates Reform Act
VCS	Voluntary Consensus Standard
WJC	William Jefferson Clinton
µm	micron

Organization of this document. The information in this preamble is organized as follows:

I. General Information

- A. Does this action apply to me?
- B. Where can I get a copy of this document and other related information?

II. Public Participation

- A. Written Comments
- B. Participation in Virtual Public Hearing

III. Background

IV. Summary of Proposed Revisions to Method 320

- A. Section 1.0 (Introduction)
- B. Section 2.0 (Summary of Method)
- C. Section 3.0 (Definitions)
- D. Section 4.0 (Interferences)
- E. Section 5.0 (Safety)
- F. Section 6.0 (Equipment and Supplies)
- G. Section 7.0 (Reagents and Standards)
- H. Section 8.0 (Sampling and Analysis Procedure)
- I. Section 9.0 (Quality Control)
- J. Section 10.0 (Calibration and Standardization)
- K. Section 11.0 (Data Analysis and Calculations)
- L. Section 12.0 (Method Performance Data Analysis and Calculations)
- M. Section 13.0 (Method Validation Procedure)
- N. Section 14.0 (Pollution Prevention)
- O. Section 15.0 (Waste Management)
- P. Section 16.0 (References)

- Q. New Section 17.0 (Tables, Diagrams, Flowcharts, and Validation Data)
- R. Addendum to Test Method 320
- IV. Statutory and Executive Order Reviews
 - A. Executive Order 12866: Regulatory Planning and Review and Executive Order 14094: Modernizing Regulatory Review
 - B. Paperwork Reduction Act (PRA)
 - C. Regulatory Flexibility Act (RFA)
 - D. Unfunded Mandates Reform Act (UMRA)
 - E. Executive Order 13132: Federalism
 - F. Executive Order 13175: Consultation and Coordination with Indian Tribal Governments
 - G. Executive Order 13045: Protection of Children from Environmental Health Risks and Safety Risks
 - H. Executive Order 13211: Actions that Significantly Affect Energy Supply, Distribution, or Use
 - I. National Technology Transfer and Advancement Act (NTTAA)
 - J. Executive Order 12898: Federal Actions to Address Environmental Justice in Minority Populations and Low-Income Populations and Executive Order 14096: Revitalizing Our Nation’s Commitment to Environmental Justice for All

I. General Information

A. Does this action apply to me?

The proposed amendments to Method 320 apply to industries that are subject to certain provisions of 40 CFR parts 60 and 63. The source categories and entities potentially affected are listed in table 1 of this preamble. This table is not intended to be exhaustive, but rather provides a guide for readers regarding entities likely to be regulated by this action. This table lists the types of entities that EPA is now aware could potentially be affected by this action. Other types of entities not listed in the table could also be regulated.

TABLE 1. POTENTIALLY AFFECTED SOURCE CATEGORIES

Category	NAICS ^a	Examples of regulated entities
Industry	321211	Plywood and Composite Wood Products
	324110	Petroleum Refineries
	325211	Polyvinyl Chloride and Copolymers Production
	327410	Lime Manufacturing Plants
	333242	Semiconductor Manufacturing
	562211	Hazardous Waste Combustors
	327993	Mineral Wool Production
	322120	Kraft Pulp and Paper Mills
	2211, 48621, 92811, 211111, 211112, and 622110	Stationary Reciprocating Internal Combustion Engines

^aNorth American Industry Classification System (2022).

If you have any questions regarding the applicability of the proposed changes to Method 320, contact the person listed in the preceding **FOR FURTHER INFORMATION CONTACT** section.

B. Where can I get a copy of this document and other related information?

The docket number for this action is Docket ID No. EPA-HQ-OAR-2022-0491. In addition to being available in the docket, an electronic copy of the proposed method revisions is available on the Technology Transfer Network (TTN) Web site at <https://www3.epa.gov/ttn/emc/methods/>. The TTN provides information and technology exchange in various areas of air pollution control.

II. Public Participation

A. Written Comments

Submit your comments, identified by Docket ID No. EPA-HQ-OAR-2022-0491, at <https://www.regulations.gov> (our preferred method), or the other methods identified in the **ADDRESSES** section. Once submitted, comments cannot be edited or removed from the docket. The EPA may publish any comment received to its public docket. Do not submit to EPA's docket at <https://www.regulations.gov> any information you consider to be Confidential Business Information (CBI), Proprietary Business Information (PBI), or other information whose disclosure is restricted by statute. Multimedia submissions (audio, video, etc.) must be accompanied by a written comment. The written comment is considered the official comment and should include discussion of all points you wish to make. The EPA will generally not consider comments or comment contents located outside of the primary submission (i.e., on the web, cloud, or other file sharing system). Please visit <https://www.epa.gov/dockets/commenting-epa-dockets> for additional submission methods; the full EPA public comment policy; information about CBI, PBI, or multimedia submissions; and general guidance on making effective comments.

B. Participation in Virtual Public Hearing

If a request for a virtual public hearing is received on or before **[INSERT DATE 7 DAYS AFTER DATE OF PUBLICATION IN THE FEDERAL REGISTER]** the EPA will hold a virtual public hearing on **[INSERT DATE 28 DAYS AFTER DATE OF PUBLICATION IN THE FEDERAL REGISTER]**. To request a virtual public hearing or to register to speak at the virtual hearing, please contact Mr. David Nash at (919) 541-9425 or *nash.dave@epa.gov*. The last day to pre-register to speak at the hearing will be **[INSERT DATE 21 DAYS AFTER DATE OF PUBLICATION IN THE FEDERAL REGISTER insert date]**. On **[INSERT DATE 25 DAYS AFTER DATE OF PUBLICATION IN THE FEDERAL REGISTER]**, the EPA will post a general agenda for the hearing that will list pre-registered speakers in approximate order at: <https://www3.epa.gov/ttn/emc/methods>.

The EPA encourages commenters to provide the EPA with a copy of their oral testimony electronically by emailing it to Mr. David Nash at *nash.dave@epa.gov*. The EPA also recommends submitting the text of your oral comments as written comments to the rulemaking docket.

The EPA may ask clarifying questions during the oral presentations but will not respond to the presentations at that time. Written statements and supporting information submitted during the comment period will be considered with the same weight as oral comments and supporting information presented at the public hearing.

Please note that any updates made to any aspect of the hearing are posted online at <https://www3.epa.gov/ttn/emc/methods>. The EPA does not intend to publish a document in the *Federal Register* announcing updates.

III. Background

Method 320 describes the procedures for the measurement of vapor phase organic and inorganic emissions by Fourier Transform Infrared (FTIR) spectroscopy. The EPA promulgated Method 320 along with the National Emissions Standards for Hazardous Air Pollutants

(NESHAP) for Portland Cement Manufacturing Industry (40 CFR part 63, subpart LLL) on June 14, 1999 (64 FR 31898) under section 112 of the Clean Air Act (CAA) as amended. Since promulgation, the EPA has incorporated the use of Method 320 for demonstrating compliance with emissions standards into numerous NESHAP and New Source Performance Standards (NSPS).

Over the 24-year period since promulgation, the use of FTIR spectroscopy has evolved as testing contractors, analytical laboratories, the EPA, and State entities have developed new standard operating procedures and methods to reflect improvements in sampling and analytical techniques. In 2017, the EPA held a series of informal discussions with stakeholders in the measurement community to identify technical issues related to measuring emissions using FTIR spectroscopy and potential revisions to Method 320. The stakeholders consisted of a cross-section of interested parties including representatives from State regulatory entities, various EPA offices, analytical laboratories, emission testing firms, analytical standards vendors, instrument vendors, and others with experience in FTIR spectroscopy and Method 320. The docket for this action contains summaries of the stakeholder discussions.

IV. Summary of Proposed Revisions to Method 320

In this action, the EPA proposes technical revisions that update the validation and quality assurance (QA) spiking procedures of Method 320 to provide a more performance-based approach. The proposed revisions would more closely align Method 320 with the EPA's approach to emissions measurement, which emphasizes specifying performance-based criteria in test methods. Instead of specifying exactly how stack testers should use or perform a particular method procedure, the method defines the criteria that must be met for a specific method element, which provides stack testers with flexibility while maintaining the quality and reliability of the measurement results. The EPA is also proposing technical revisions and editorial changes to clarify and update the requirements and procedures specified in Method 320, including removing the batch sampling procedures.

A. Section 1.0 (Introduction)

In this action, the EPA proposes to revise the name of section 1.0 from “Introduction” to “Scope and Application,” to update the introductory paragraph to remove references to the FTIR Protocol, and to remove the note regarding use of sample conditioning systems. The EPA also proposes to renumber and update sections 1.1.1 (Analytes) and 1.1.2 (Applicability) to sections 1.1 and 1.2, respectively, and to replace the existing sections 1.2 (Method Range and Sensitivity), 1.3 (Sensitivity), and 1.4 (Data Quality) with a revised section 1.3 (Data Quality Objectives).

B. Section 2.0 (Summary of Method)

In this action, the EPA proposes to update section 2.0 by revising sections 2.1 (Principle) and 2.2 (untitled) and removing sections 2.3 (Reference Spectra Availability) and 2.4 (Operator Requirements). In section 2.1, the EPA proposes to remove the title and consolidate sections 2.1.1 through 2.1.5 and the introductory paragraph to section 2.2 (Sampling and Analysis) into a single paragraph. In section 2.2, the EPA also proposes to remove the discussion of Beer’s Law in section 2.2.1 and to update the references to method evaluation and validation and pre-test procedures.

C. Section 3.0 (Definitions)

In this action, the EPA proposes to remove the following definitions for technical terms that are not needed in the proposed Method 320 and for terms commonly used in the emissions measurement community for which a definition is unnecessary:

- Batch Sampling.
- Concentration.
- Continuous Sampling.
- Emissions Test.
- Gas Cell.
- Independent Sample.
- Interferant.
- Measurement.
- One Hundred Percent Line.
- Quantitation Limit.
- Reference Calibration Transfer Standard (CTS).
- Sample Analysis.
- Sampling Resolution.
- Sampling System.
- Screening.
- Sensitivity.
- Standard Spectrum.
- Surrogate.
- Test CTS.
- Truncation.
- Zero Filling.
- Validation.

- Root Mean Square Difference.
- Validation Run.

The EPA also proposes revisions to five definitions currently used in Method 320. Table 2 of this preamble presents the proposed revisions for each definition.

TABLE 2. PROPOSED REVISIONS TO EXISTING DEFINITIONS

Term	Revision	Proposed definition
Analyte	Clarify that Method 320 can measure more than one analyte per test.	<i>Analyte</i> means a compound that the method is intended to measure. This method is a multi-component method; therefore, several analytes may be targeted for a given test.
Background Deviation	Move the performance criteria from the definition to revised section 13.2 (Background Deviation).	<i>Background deviation</i> means a deviation from 100% transmittance in any region of the 100% line.
CTS [Calibration Transfer Standard]	Update the definition to remove the redundant “standard” in the term and to specify the acceptable CTS gases.	<i>Calibration transfer standard (CTS)</i> means a certified gas calibration standard used to verify instrument stability. For the purposes of this method, the CTS must be ethylene, methane, or carbon dioxide. Other compounds may be used only with the Administrator’s approval.
Reference Spectrum	Change the term to plural (<i>i.e.</i> , “Reference Spectra”), clarify the definition, and remove the reference to the FTIR Protocol.	<i>Reference spectra</i> means a spectra of a pure sample gas obtained at a known concentration under controlled conditions of pressure, temperature, and pathlength.
Run	Replace “measurements” with “samples” and remove the minimum requirement specifications.	<i>Run</i> means a series of samples taken successively from the stack or duct. A test normally consists of a specific number of runs.

The EPA also proposes to add definitions for the key technical terms shown in table 3 of this preamble to improve the clarity of the principles and procedures used in Method 320.

TABLE 3. PROPOSED NEW DEFINITIONS

Term	Proposed definition
Absorbance	The negative logarithm of transmission represented by the relationship $A = -\log(I/I_0)$, where I is the transmitted intensity of light, and I_0 is the incident intensity of light upon a molecule.
Absorptivity	The amount of infrared radiation absorbed by each molecule.
Analyte Spiking	The process of quantitatively adding calibration standards to source effluent. Analyte spiking is used to evaluate the ability of the sample transport and FTIR measurement systems to quantify the target analyte(s).
Analytical Algorithm	The method used to quantify the concentration of both target analyte(s) and additional compounds in a sample matrix that may introduce analytical interferences in each FTIR spectrum.

Term	Proposed definition
Analytical Interference	A spectral feature that complicates, and may even prevent, the analysis of an analyte. Analytical interferences can be background or spectral interferences. Background interferences result from a change in light throughput relative to the single beam background. This can be due to factors such as deposits on reflective surfaces and windows, temperature changes, a change in detector sensitivity, a change in infrared source output, or instrument electronics failure. Spectral interferences arise due to the presence of interfering compounds that have overlapping absorption features with the analytes of interest.
Apodization	A mathematical transformation that is used to adjust the instrument line shape for measured peaks. There are various types of apodization functions; the most common are boxcar, triangular, Happ-Genzel, and Beer-Norton functions.
Background Spectrum	A spectrum taken in the absence of absorbing species or sample gas matrix, typically conducted using nitrogen or zero air.
Bandwidth	The width of a spectral feature. This width is commonly listed as the full width at half the maximum of the spectral feature.
Beam Splitter	A device located in the interferometer that divides the incoming infrared radiation into two separate beams that travel two separate paths before recombination.
Classical Least Squares	A method of analyzing multicomponent spectra by scaling reference absorbance spectra to unknown measured spectra.
Double Beam Spectrum	A transmission or absorbance spectrum derived by dividing the sample single beam spectrum by the background spectrum.
Fourier Transform	A mathematical transform that allows the conversion of the detector response as a function of time to intensity as a function of frequency.
Fundamental CTS	An NIST-traceable CTS reference spectrum with known temperature and pressure that has been obtained using an absorption cell with an accurately known optical pathlength.
Interferogram	A pattern that contains the effects of the wave interference that are produced from an interferometer.
Interferometer	A device used to produce interference spectra, by dividing a beam of radiant energy into two or more paths. One path strikes a fixed mirror and the second path strikes a moving mirror generating an optical path difference that varies over time between them. The recombined beams produce constructive and destructive interference as a function of changing pathlength. The Michelson interferometer, used in FTIR instruments, performs this function.
Partial Least Squares	A method for analyzing multicomponent spectra by combining features from principal component and multiple regression analysis. It has been found to be most useful when predicting a set of dependent variables from a large set of independent variables.
Resolution	The minimum separation that two spectral features must have to distinguish one feature from the another.
Retardation	The optical path difference between two beams in an interferometer.
Single Beam Spectrum	The Fourier transformed interferogram representing detector response versus wavenumber.
Test	The series of runs required by the applicable regulation.

Term	Proposed definition
Tracer Gas	A stable, non-reactive species that is easily transportable and can be blended in a gas cylinder with a target analyte to confirm the dilution ratio of a dynamic spike.
Transmittance	The amount of infrared radiation that is not absorbed by the sample. Percent transmittance is represented by the following equation: $\%T = (I/I_0) \times 100$.

D. Section 4.0 (Interferences)

In section 4.0 (Interferences), the EPA proposes to consolidate sections 4.1 (Analytical Interferences) and 4.2 (Sampling System Interferences) into revised section 4.0 and to incorporate the discussion of background and spectral interferences in sections 4.1.1 and 4.1.2, respectively, into the definition of “Analytical Interference.” The EPA also proposes to remove sections 4.1.1, 4.1.2, and 4.2.

E. Section 5.0 (Safety)

In this action, the EPA proposes updates to the language of section 5.0, including a recommendation to provide safety data sheets for gas standards to all personnel using the method.

F. Section 6.0 (Equipment and Supplies)

In this action, the EPA proposes to organize the equipment list in section 6.0 into analytical instrumentation and sampling system components. The EPA also proposes to remove the descriptions of the following equipment, which are not needed to perform revised Method 320:

- Calibration/Analyte Spike Assembly.
- Mass Flow Meter.
- Rotameter.
- FTIR Cell Pump.

In this action, the EPA proposes to revise the current descriptions for the equipment components shown in table 4 of this preamble.

TABLE 4. PROPOSED REVISIONS TO EXISTING DEFINITIONS

Equipment	Revision	Proposed description
FTIR Analytical System	Change “FTIR Analytical System” to “FTIR Spectrometer,” clarify the description, and remove the requirement that the system include a personal computer and processing software.	An instrument that collects and digitizes the spectral interference pattern from an interferometer and mathematically transforms this signal into infrared frequency spectra.
Gas Regulators	Clarify the description and add recommendations regarding materials of construction.	A regulator used to introduce individual gas or gas mixtures from cylinders. Regulator should be constructed of the appropriate materials that minimize analyte adsorption and reactivity.
Gas Sample Manifold	Change “Gas Sample Manifold” to “Gas Distribution Manifold” and clarify the description to include requirements for accurately diluting calibration gas, monitoring calibration gas pressure, and precisely introducing analyte spikes.	A manifold capable of delivering nitrogen or calibration gases through the sampling system or directly to the FTIR. The calibration gas manifold must provide accurate dilution of the calibration gas as necessary, monitor calibration gas pressure, and introduce analyte spikes into the sample stream (prior to the particulate filter) at a precise and known flowrate.
Particulate Filters	Clarify the description and remove the example cited.	A glass wool plug (optional) inserted at the probe tip (for large particulate removal) and a filter (required) connected at the outlet of the heated probe and rated for 99% removal efficiency of 1 micron (μm) aerodynamic particulate.
Polytetrafluoroethane Tubing	Incorporate the description into a single description for “Tubing.”	Polytetrafluoroethane (PTFE), 316-stainless steel, or other inert material, of suitable length and diameter used to connect cylinder regulators to the gas manifold.
Sampling Line/Heating System	Change “Sampling Line/Heating System” to “Sample Line” and clarify that the construction material should minimize adsorption of analytes and the length of line needed.	Heated to prevent sample condensation, and made of stainless steel, PTFE, or other material that minimizes adsorption of analytes. Line length should be the minimum necessary to reach sampling locations.

Equipment	Revision	Proposed description
Sample Pump	Update the minimum flow rate requirements, clarify the options for pump placement, remove the requirement to record the gas cell sample pressure for pumps located downstream of the FTIR system, and remove the example cited.	A leak-free pump with bypass valve, capable of producing a sample flow rate equal to 5 cell volumes per sample cycle. The pump may be positioned upstream or downstream of the FTIR cell. If the pump is positioned upstream of the distribution manifold and FTIR system, use a heated head pump that is constructed from materials non-reactive with the analytes of interest.
Sample Conditioning	Clarify the role of the optional sample conditioning in the sampling system.	An optional part of the sampling system used to dilute or remove particulate matter, water vapor, or other interfering species depending upon the source matrix composition.
Sampling Probe	Clarify the description and remove the example for high-temperature stack samples and the recommendation to use a dilution probe for high-moisture sources.	Glass, stainless steel, PTFE, or other appropriate material to transport analytes to the IR gas cell. The sampling probe must be capable of sustained heating to prevent water condensation and adsorption of analytes.
Stainless Steel Tubing	Incorporate the description into a single description for "Tubing."	PTFE, 316-stainless steel, or other inert material, of suitable length and diameter used to connect cylinder regulators to the gas manifold.

The EPA also proposes to add descriptions for the equipment components shown in table 5 of this preamble.

TABLE 5. PROPOSED NEW EQUIPMENT DESCRIPTIONS

Term	Proposed description
Computer/Data Acquisition System	A computer with compatible FTIR software for control of the FTIR system, acquisition of infrared (IR) data, and analysis of resulting spectra. This system must have enough data storage space to archive all necessary infrared and meta data (see section 11.6 of this method).
Gas Absorption Cell	The container through which the infrared beam interacts with the sample gas. The gas absorption cell must have the ability to monitor the pressure and temperature of the sample gas.
Sampling System	The sampling system consists of the components listed in sections 6.2.1 through 6.2.9 of this method, validated as detailed in section 9.4.

G. Section 7.0 (Reagents and Standards)

In this action, the EPA proposes to rename current section 7.1 from "Analyte(s) and Tracer Gas" to "Analyte(s) and Tracer Standard Gases" and to require the use of EPA protocol

gases (with expanded uncertainty $\leq 2\%$) be used for criteria pollutants. The EPA proposes to specify that other pollutants (non-criteria) be dual certified and that target analytes be within 25% of the emission source level or applicable compliance limit. The EPA also proposes to remove the suggestion regarding the use of sulfur hexafluoride (SF_6) tracer gas. The EPA is specifically soliciting comment on the approach of using expanded uncertainty for criteria pollutants as well as not being prescriptive on the tracer that is used.

In section 7.2 (Calibration Transfer Standard(s)), the EPA proposes to remove the requirements to select CTS according to section 4.5 of the FTIR Protocol and to obtain a NIST-traceable standard. The EPA also proposes to clarify that the CTS must be vendor-certified to ± 2 percent of the cylinder tag value and specifying the list of CTS standard gases that may be used. The EPA is soliciting comments regarding CTS gases and providing standardization there to ensure coverage over a wide wavelength range by using one of the listed gases.

The EPA also proposes to change the name of section 7.3 from “Reference Spectra” to “Chemical Standards,” and to replace the reference to EPA reference spectra and procedures in the FTIR Protocol for preparing reference spectra with requirements to use NIST-certified or NIST-traceable, vendor-certified chemical standards that meet an accuracy specification of ± 5 percent for preparing reference spectra.

H. Section 8.0 (Sampling and Analysis Procedure)

In this action, the EPA proposes to change the name of section 8.0 from “Sampling and Analysis Procedure” to “Sample Collection, Preservation, Storage, and Transport,” to clarify the purpose of the section in the introductory paragraph, and to remove the list of testing requirements. The EPA proposes to remove the recommendation to obtain an initial spectrum for determining a suitable operational path length and the reference to Figure 1 (sampling train).

In section 8.1 (currently Pretest Preparations and Evaluations), the EPA proposes to rename the section to “Pretest Preparations” and to remove reference to section 4 of the FTIR Protocol for determining the optimum sampling system configuration. In section 8.2 (Leak-

Check), the EPA proposes to remove the hyphen from the section title, add a statement for the user to follow the leak check procedures in the proposed revised section 11.1 (Leak Check), and remove sections 8.2.1 (Sampling System) and 8.2.2 (Analytical System Leak Check).

In section 8.3 (Detector Linearity), the EPA proposes to replace the text with a statement for the user to follow the detector linearity verification procedures in proposed revised section 11.2 (Detector Linearity). The EPA proposes to remove sections 8.3.1 and 8.3.2, which provide the options to verify detector linearity by varying the power incident on the detector by modifying the aperture setting or by using neutral density filters to attenuate the infrared beam in current, respectively. The EPA also proposed to incorporate section 8.3.3 into the proposed revised section 11.2.

For section 8.4 (Data Storage Requirements), the EPA proposes to replace the data storage requirements with a statement for the user to follow the data storage requirements in new proposed section 11.8 (Digital Data Storage). The EPA also proposes to remove the requirement to prepare a backup copy of the field test spectra and the requirement to record sample conditions, instrument settings, and test records.

In section 8.5 (Background Spectra), the EPA proposes to remove the requirement to evacuate the gas cell and fill the cell with dry nitrogen to ambient pressure. The EPA also proposes to remove the requirement to create a backup copy of the background interferogram and processed single-beam spectrum and remove sections 8.5.1 (Interference Spectra) and 8.5.2 for collection of water vapor spectra.

For section 8.6 (Pre-Test Calibrations), the EPA proposes to revise the requirements for the CTS in section 8.6.1 (Calibration Transfer Standard) and to replace the QA spike requirements in section 8.6.2 (QA Spike) with a statement for the user to follow the QA spike requirements in new proposed section 11.4 (QA Spike).

The EPA proposes to revise section 8.7 (Sampling) by replacing the introductory paragraph with a statement for the user to follow the sampling procedures specified in new

proposed section 11.5 (Stratification Check). The EPA also proposes to incorporate the requirements for the signal transmittance from section 8.9 (Sampling QA and Reporting) into the introductory paragraph and to remove sections 8.7.1 (Batch Sampling) and 8.7.2 (Continuous Sampling).

For section 8.8 (Sampling QA and Reporting), the EPA proposes to rename the section “Post-Run CTS” and add a requirement to record a post-run CTS. The EPA proposes to incorporate the requirement that sample integration times be sufficient to achieve the required signal-to-noise ratio from section 8.8.1 into a proposed revised section 9.1.1.1. The EPA also proposes to remove sections 8.8.1, 8.8.2, 8.8.3, and 8.8.4 and instead specify the requirements to assign unique file names, store two copies of interferograms and spectra, and prepare sample spectrum documentation, respectively.

For section 8.9 (Signal Transmittance), the EPA proposes to incorporate the requirements for the signal transmittance from section 8.9 into revised section 8.7, and to replace the text in section 8.9 with a proposed requirement to perform post-run QA according to proposed revised section 9.1.2 (Post-Run QA).

In section 8.10 (Post-Test QA), the EPA proposes to move the post-test CTS requirements to new proposed section 11.6 (Post-Test CTS). The EPA also proposes to move section 8.11 (Post-Test QA) to proposed revised section 9.1.2 (Post-Run QA).

I. Section 9.0 (Quality Control)

In this action, the EPA proposes to rename section 9.0 to “Quality Assurance and Quality Control” and to remove the introductory sentence. The EPA proposes to replace section 9.1 (Spike Materials), which specifies the accuracy requirements for spike materials, with revised section 9.1 (Quality Assurance) and to add requirements for performing pre-test QA. The EPA proposes to move the existing section 8.11 to the proposed revised section 9.1.2 and to remove the reference to the FTIR Protocol.

For section 9.2 (Spiking Procedure), the EPA proposes to replace the spiking procedures with a proposed revised section 9.2 (Quality Control) stating that analyte spike procedure in new proposed section 9.3 (Spike Procedure) and the validation procedure in new proposed section 9.4 (Method Validation Procedure) evaluate the sampling system performance and quantify sampling system effects on the measured concentrations. The EPA also proposes to clarify that the method is self-validating, provided that the results meet the performance requirement of the QA spike in new proposed section 11.4, and to remove the requirement that the results from a previous method validation support the use of this method in the application.

J. Section 10.0 (Calibration and Standardization)

In this action, the EPA proposes updates to section 10.0 by replacing section 10.1 (Signal-to-Noise Ratio) with a revised section 10.1 (Analytes) that specifies the procedures for calibrating and standardizing analytes, replacing section 10.2 (Absorbance Path Length) with a revised section 10.2 (Interferents), and replacing section 10.3 (Instrument Resolution) with revised section 10.3 (CTS Absorption Bands). The EPA proposes to replace section 10.4 (Apodization Function) with a revised section 10.4 (Reference Spectra), which would provide users with procedures for collecting reference spectra, and to replace section 10.5 (FTIR Cell Volume) with a revised section 10.5 (Absorption Cell Path Length Determination), which would specify the revised procedures for determining the absorption cell path length. The EPA also proposes to add new section 10.6 (Instrument Resolution) to revise procedures for determining instrument resolution.

K. Section 11.0 (Data Analysis and Calculations)

In this action, the EPA proposes to change the title of current section 11.0 to “Method Procedures.” The EPA proposes to replace section 11.1 (Spectral De-Resolution) with a revised section 11.1 that would provide two options to verify that there are no significant vacuum-side leaks (*i.e.*, the low-flow test and the vacuum-decay test) and to replace section 11.2 (Data Analysis) with a revised section 11.2 that would incorporate the requirements in the current

introductory paragraph for section 8.3 and requirements in section 8.3.3. The EPA also proposes to add several new sections as summarized in table 6 of this preamble. The EPA requests comment on these leak check approaches.

TABLE 6. PROPOSED ADDITIONS TO SECTION 11

Section	Description
11.3 (Gas Cell Pathlength)	Requires verification of the gas cell pathlength according to the procedures in revised section 10.6.4.
11.4 (QA Spike)	Clarifies that the QA spike procedure assumes that the method has been validated for each of the target analyte at the source, rather than for only some of the target analytes as specified in current section 8.6.2 and presents the revised QA spike procedures for use of a certified standard or use of a non-certified standard.
11.5 (Sampling)	Specifies the revised sampling procedures, including performing a stratification check.
11.6 (Post-Test CTS)	Requires comparison of the pre- and post-test CTS spectra.
11.7 (Record and Report)	Specifies the revised recording and reporting requirements.
11.8 (Digital Data Storage)	Incorporates the requirements from section 8.4.

L. Section 12.0 (Method Performance Data Analysis and Calculations)

For section 12.0, the EPA proposes to rename the section “Data Analysis and Calculations” and to replace section 12.1 (Spectral Quality) with a revised section 12.1 that specifies the required capabilities of the concentration algorithm. The EPA also proposes to remove section 12.2 (Sampling QA/QC).

M. Section 13.0 (Method Validation Procedure)

In this action, the EPA proposes to rename current section 13.0 from “Method Validation Procedure” to “Method Performance” and to remove the introductory paragraph. The EPA also proposes to replace section 13.1 with a revised section 13.1 (Detection Level), which would include the proposed requirement that the detection level must be within 20 percent of the applicable compliance limit, and to replace section 13.2 (Batch Sampling) with a revised section 13.2 (Background Deviation), which would incorporate the performance criteria in the current definition of “Background Deviation.”

N. Section 14.0 (Pollution Prevention)

In section 14.0, the EPA proposes to remove the sentence describing the mass of HAP that may be emitted by the extracted sample gas for a typical 3-hour validation run.

O. Section 15.0 (Waste Management)

The EPA is not proposing any changes to section 15.0 in this action.

P. Section 16.0 (References)

In section 16.0, the EPA proposes to remove references 1, 2, 4, and 5 through 7, and to add the reference citation and link for the FTIR Protocol (the current addendum to Method 320).

Q. Section 17.0 (Tables, Diagrams, Flowcharts, and Validation Data)

In this action, the EPA proposes to add new section 17.0, to update Figure 1 (Extractive FTIR Sampling System), and to remove Table 1 (Example Presentation of Sampling Documentation) and Figure 2 (Fractional Reproducibility).

R. Addendum to Test Method 320

In this action, the EPA proposes to remove the addendum and associated appendices from Method 320. The proposed revised section 16.0 will include a reference citation and link for the FTIR Protocol.

IV. Statutory and Executive Order Reviews

Additional information about these statutes and Executive orders can be found at <https://www2.epa.gov/laws-regulations/laws-and-executive-orders>.

A. Executive Order 12866: Regulatory Planning and Review and Executive Order 14094: Modernizing Regulatory Review

This action is not a significant regulatory action as defined in Executive Order 12866, as amended by Executive Order 14094, and was therefore not subject to a requirement for Executive Order 12866 review.

B. Paperwork Reduction Act (PRA)

This action does not impose an information collection burden under the PRA. The revisions being proposed in this action to Method 320 do not add information collection requirements but make corrections, clarifications, and updates to existing testing methodology.

C. Regulatory Flexibility Act (RFA)

I certify that this action will not have a significant economic impact on a substantial number of small entities under the RFA. This proposed action will not impose any requirements on small entities. The proposed revisions to Method 320 do not impose any requirements on regulated entities. Rather, the proposed changes improve the quality of the results when required by other rules to use Method 320. Revisions proposed for Method 320 allow contemporary advances in analysis techniques to be used.

D. Unfunded Mandates Reform Act (UMRA)

This action does not contain any unfunded mandate as described in UMRA, 2 U.S.C. 1531-1538, and does not significantly or uniquely affect small governments. This action imposes no enforceable duty on any State, local or Tribal governments or the private sector.

E. Executive Order 13132: Federalism

This action does not have federalism implications. It will not have substantial direct effects on the States, on the relationship between the national government and the States, or on the distribution of power and responsibilities among the various levels of government.

F. Executive Order 13175: Consultation and Coordination with Indian Tribal Governments

This action does not have Tribal implications as specified in Executive Order 13175. The revisions being proposed in this action make corrections, clarifications, and updates to existing testing methodology. Thus, Executive Order 13175 does not apply to this action.

G. Executive Order 13045: Protection of Children from Environmental Health Risks and Safety Risks

The EPA interprets Executive Order 13045 as applying only to those regulatory actions that concern environmental health or safety risks that the EPA has reason to believe may

disproportionately affect children, per the definition of “covered regulatory action” in section 2-202 of the Executive order.

Therefore, this action is not subject to Executive Order 13045 because it does not concern an environmental health risk or safety risk. Since this action does not concern human health, EPA’s Policy on Children’s Health also does not apply.

H. Executive Order 13211: Actions that Significantly Affect Energy Supply, Distribution or Use

This action is not subject to Executive Order 13211 because it is not a significant regulatory action under Executive Order 12866.

I. National Technology Transfer and Advancement Act (NTTAA)

This action involves technical standards. While the EPA identified ASTM D6348 as being potentially applicable, the Agency does not propose to use it. Currently, ASTM International (formerly the American Society for Testing and Materials) is revising ASTM D6348 (Standard Test Method for Determination of Gaseous Compounds by Extractive Direct Interface FTIR Spectroscopy), which specifies sampling and analytical procedures that are similar to EPA Method 320. Because the revised ASTM D6348 may be an equivalent method, the EPA will reconsider it when the revised ASTM D6348 becomes available.

J. Executive Order 12898: Federal Actions to Address Environmental Justice in Minority Populations and Low-Income Populations and Executive Order 14096: Revitalizing Our Nation’s Commitment to Environmental Justice for All

The EPA believes that this type of action does not concern human health or environmental conditions and, therefore, cannot be evaluated with respect to potentially disproportionate and adverse effects on communities with environmental justice concerns. This action would correct, update, and clarify Method 320 to improve the quality of the results when used.

List of Subjects in 40 CFR Part 63

Environmental protection, Air pollution control, Hazardous air pollutants, Method 320, FTIR, Test methods.

Michael S. Regan,

Administrator.

For the reasons stated in the preamble, the Environmental Protection Agency proposes to amend title 40, chapter I of the Code of Federal Regulations as follows:

**PART 63—NATIONAL EMISSION STANDARDS FOR HAZARDOUS AIR
POLLUTANTS FOR SOURCE CATEGORIES**

1. The authority citation for part 63 continues to read as follows:

Authority: 42 U.S.C. 7401 *et seq.*

2. Appendix A to part 63 is amended by revising Test Method 320 to read as follows:

Appendix A to Part 63—Test Methods

* * * * *

**Test Method 320—Measurement of Vapor Phase Organic and Inorganic Emissions by
Extractive Fourier Transform Infrared (FTIR) Spectroscopy**

1.0 Scope and Application

This method describes the extractive sampling and quantitative analysis of gaseous compounds in stationary source effluent using Fourier transform infrared (FTIR) spectrometry. Analysis procedures, quality control, and quality assurance requirements are included to assure that you, the tester, collect data of known and acceptable quality for each testing program.

1.1 Analytes. This method is designed to measure individual gas phase hazardous air pollutants (HAPs) for which reference spectra have been developed. Other gas phase compounds can also be measured with this method so long as reference spectra obtained according to section 10.5 of this method are used. Candidate gaseous compounds must have infrared features (i.e., a non-zero dipole moment) to be detected using this method.

1.2 Applicability. This method applies to the analysis of vapor phase compounds that absorb energy in the mid-infrared spectral region, from about 400 to 4000 cm^{-1} (25 to 2.5 μm). The method is used to determine compound-specific concentrations in a multi-component gas sample extracted from a stack or ducted source.

1.3 Data Quality Objectives (DQOs). Method 320 contains performance-based DQOs to provide data of known quality. With this method, you must evaluate the accuracy and precision of data in each gas matrix and at actual emissions concentrations that are encountered during its application. Data quality requirements include appropriate field evaluation procedures.

2.0 Summary of Method

2.1 A sample is extracted from the source at a constant rate. Samples are conditioned, if necessary, and transported via heated lines composed of inert material (to prevent condensation of the measured compounds) from the source to a heated cell in the FTIR, wherein data are generated by directing an infrared beam through the sample to a detector. Most molecules absorb infrared radiation, and the absorbance occurs in a characteristic and reproducible pattern. FTIR data are transformed into a frequency-based spectra and curve fitting calculations (e.g., classical least squares, partial least squares) are used to determine compound quantities and minimize residuals. Target compound concentrations are determined using their unique infrared absorption features and reference calibration spectra. This method may be used simultaneously for multiple gaseous components.

2.2 Measurement evaluation and validation for a source gas matrix are described in section 9.2 of this method. Pre-test preparation and procedures are described in section 8.1 of this method.

These procedures are designed to verify that an appropriate sampling system has been chosen and performs in a manner that provides results of known and acceptable quality is also discussed. Dynamic spiking is used to confirm target compound transport accuracy in potentially complex matrices.

3.0 Definitions

3.1 *Absorbance* means the negative logarithm of transmission represented by the relationship $A = -\log(I/I_0)$, where I is the transmitted intensity of light, and I_0 is the incident intensity of light upon a molecule.

3.2 *Absorptivity* means the amount of infrared radiation absorbed by each molecule.

3.3 *Analyte* means a compound that the method is intended to measure. This method is a multi-component method; therefore, several analytes may be targeted for a given test.

3.4 *Analyte spiking* means the process of quantitatively adding calibration standards to source effluent. Analyte spiking is used to evaluate the ability of the sample transport and FTIR measurement systems to quantify the target analyte(s).

3.5 *Analytical algorithm* means the method used to quantify the concentration of both target analyte(s) and additional compounds in a sample matrix that may introduce analytical interferences in each FTIR spectrum.

3.6 *Analytical interference* means a spectral feature that complicates, and may even prevent, the analysis of an analyte. Analytical interferences can be background or spectral interferences. Background interferences result from a change in light throughput relative to the single beam background. This can be due to factors such as deposits on reflective surfaces and windows, temperature changes, a change in detector sensitivity, a change in infrared source output, or instrument electronics failure. Spectral interferences arise due to the presence of interfering compounds that have overlapping absorption features with the analytes of interest.

3.7 *Apodization* means a mathematical transformation used to adjust the instrument line shape for measured peaks. There are various types of apodization functions; the most common are boxcar, triangular, Happ-Genzel, and Beer-Norton functions.

3.8 *Background deviation* means a deviation from 100% transmittance in any region of the 100% line.

3.9 *Background spectrum* means a spectrum taken in the absence of absorbing species or sample gas matrix, typically conducted using nitrogen or zero air.

3.10 *Bandwidth* means the width of a spectral feature. This width is commonly listed as the full width at half the maximum of the spectral feature.

3.11 *Beam splitter* means a device located in the interferometer that divides the incoming infrared radiation into two separate beams that travel two separate paths before recombination.

3.12 *Calibration transfer standard (CTS)* means a certified gas calibration standard used to verify instrument stability. For the purposes of this method, the CTS must be ethylene, methane, or carbon dioxide. Other compounds may be used only with administrator approval.

3.13 *Classical least squares (CLS)* means a method of analyzing multicomponent spectra by scaling reference absorbance spectra to unknown measured spectra.

3.14 *Double beam spectrum* means a transmission or absorbance spectrum derived by dividing the sample single beam spectrum by the background spectrum.

Note: The term “double-beam” is used elsewhere to denote a spectrum in which the sample and background interferograms are collected simultaneously along physically distinct absorption paths. In this method, the term denotes a spectrum in which the sample and background interferograms are collected at different times along the same absorption path.

3.15 *Fourier transform* means a mathematical transform that allows the conversion of the detector response as a function of time to intensity as a function of frequency.

3.16 *Fundamental CTS* means an NIST-traceable CTS reference spectrum with known temperature and pressure, that has been obtained using an absorption cell with an accurately known optical pathlength.

3.17 *Interferogram* means a pattern that contains the effects of the wave interference that are produced from an interferometer.

3.18 *Interferometer* means a device used to produce interference spectra, by dividing a beam of radiant energy into two or more paths. One path strikes a fixed mirror, and the second path strikes a moving mirror generating an optical path difference that varies over time between them. The recombined beams produce constructive and destructive interference as a function of changing pathlength. The Michelson interferometer, used in FTIR instruments, performs this function.

3.19 *Partial least squares* means a method for analyzing multicomponent spectra by combining

features from principal component and multiple regression analysis. It has been found to be most useful when predicting a set of dependent variables from a large set of independent variables.

3.20 *Reference spectra* means a spectra of a pure sample gas obtained at a known concentration under controlled conditions of pressure, temperature, and pathlength.

3.21 *Resolution* means the minimum separation that two spectral features must have to distinguish one feature from the another.

3.22 *Retardation* means the optical path difference between two beams in an interferometer.

3.23 *Run* means a series of samples taken successively from the stack or duct. A test normally consists of a specific number of runs.

3.24 *Single beam spectrum* means the Fourier transformed interferogram representing detector response versus wavenumber.

3.25 *Test* means the series of runs required by the applicable regulation.

3.26 *Tracer gas* means a stable, non-reactive species that is easily transportable and can be blended in a gas cylinder with a target analyte to confirm the dilution ratio of a dynamic spike.

3.27 *Transmittance* means the amount of infrared radiation that is not absorbed by the sample. Percent transmittance is represented by the following equation: $\%T = (I/I_0) \times 100$.

4.0 *Interferences*

Interferences to precise, accurate measurement using FTIR include both analytical interferences defined in section 3.6 of this method, and sampling system interferences. Sampling system interferences are conditions that prevent analytes from reaching the instrument due to factors such as sample line temperature, sample line materials, condensation, and sample transport time.

5.0 *Safety*

This method does not address all potential safety risks associated with its use. The hazards of performing this method are those associated with any stack sampling method. Anyone performing this method must follow safety and health practices consistent with stationary source sampling, including applicable legal and site-specific safety requirements. Many HAPs measured

by this method are suspected toxic or hazardous and may present serious health risks. Exposure to these compounds from stack gas or from spiking standards should be avoided. Ensure safety data sheets (SDS) for gas standards are available to all personnel using this method. When using analyte standards, ensure that gases are properly vented and that the gas handling system is leak free.

6.0 Equipment and Supplies

The equipment and supplies described in this section are based on the schematic of the example sampling system shown in Figure 1.

6.1 Analytical Instrumentation.

6.1.1 Fourier Transform Infrared (FTIR) Spectrometer. An instrument that collects and digitizes the spectral interference pattern from an interferometer and mathematically transforms this signal into infrared frequency spectra.

6.1.2 Computer/Data Acquisition System. A computer with compatible FTIR software for control of the FTIR system, acquisition of infrared (IR) data, and analysis of resulting spectra. This system must have enough data storage space to archive all necessary infrared and meta data (see section 11.6 of this method).

6.1.3 Gas Absorption Cell. The container through which the infrared beam interacts with the sample gas. The gas absorption cell must have the ability to monitor the pressure and temperature of the sample gas.

6.2 Sampling System. The sampling system consists of the components listed in sections 6.2.1 through 6.2.9 of this method and validated as detailed in section 9.4.

6.2.1 Sampling Probe. Glass, stainless steel, polytetrafluoroethane (PTFE), or other appropriate material to transport analytes to the IR gas cell. The sampling probe must be capable of sustained heating to prevent water condensation and adsorption of analytes.

Note: High stack sample temperatures may require special steel or cooling of the probe. For very high moisture sources, it may be desirable to use a dilution probe. Special materials or configurations may be required for probes to traverse ducts or stacks.

6.2.2 Particulate Filters. A glass wool plug (optional) inserted at the probe tip (for large particulate removal) and a filter (required) connected at the outlet of the heated probe and rated for 99% removal efficiency of 1 micron aerodynamic particulate.

6.2.3 Sampling Line. Heated to prevent sample condensation, and made of stainless steel, PTFE, or other material that minimizes adsorption of analytes. Line length should be the minimum necessary to reach sampling locations.

6.2.4 Sample Pump. A leak-free pump with bypass valve, capable of producing a sample flow rate equal to 5 cell volumes per sample cycle. The pump may be positioned upstream or downstream of the FTIR cell. If the pump is positioned upstream of the distribution manifold and FTIR system, use a heated head pump that is constructed from materials non-reactive with the analytes of interest.

6.2.5 Gas Distribution Manifold. A manifold capable of delivering nitrogen or calibration gases through the sampling system or directly to the FTIR. The calibration gas manifold must provide accurate dilution of the calibration gas as necessary, monitor calibration gas pressure, and introduce analyte spikes into the sample stream (prior to the particulate filter) at a precise and known flowrate.

6.2.6 Sample Conditioning. An optional part of the sampling system used to dilute or remove particulate matter, water vapor, or other interfering species depending upon the source matrix composition.

6.2.7 Gas Regulator. A regulator used to introduce individual gas or gas mixtures from cylinders. Regulator should be constructed of the appropriate materials that minimize analyte adsorption and reaction with the regulator.

6.2.8 Tubing. PTFE, 316-stainless steel, or other inert material, of suitable length and diameter used to connect cylinder regulators to the gas manifold.

7.0 Reagents and Standards

7.1 Analyte(s) and Tracer Standard Gases. Analyte(s) and tracer gases must come from gas cylinder(s). Criteria pollutants must use EPA Protocol gases, or equivalent (i.e., compressed gas standards with an expanded uncertainty of $\leq 2\%$). All other pollutants must use “dual certified” compressed gas standards (i.e., standards certified by two independent techniques). Target analyte concentrations should be within $\pm 25\%$ of the emission source levels or the applicable compliance limit unless otherwise prescribed in the applicable standard. If practical, the analyte standard cylinder shall also contain the tracer gas at a concentration that gives a measurable absorbance at a dilution factor of at least 10:1.

7.2 Calibration Transfer Standard (CTS). The CTS standard must be NIST-traceable, per methods specified in the *EPA Traceability Protocol for Assay and Certification of Gaseous Calibration Standards*, to $\pm 2\%$ of the cylinder tag value. The CTS standard must be one of the following gases: ethylene, methane, or carbon dioxide.

7.3 Chemical Standards. Chemical standards used to generate reference spectra must be NIST certified via gravimetric measurement, or NIST-traceable and vendor-certified accurate to within $\pm 5\%$.

8.0 Sample Collection, Preservation, Storage, and Transport

8.1 Pretest Preparations. Determine the optimum sampling system configuration for measuring the target analytes. Use available information to make reasonable assumptions about moisture content and other interferences.

8.1.1 Sampling System.

8.1.1.1 Based on the source gas characteristics (e.g., temperature, pressure profiles, moisture content, target and interference physical characteristics, and particulate concentration), select the equipment for extracting and transporting gas samples.

8.1.1.2 Select the techniques and/or equipment for the measurement of sample pressures and temperatures in the sample cell.

8.1.1.3 Heat sample transport lines to maintain sample temperature at least 10 °F (5 °C) above the dew point for all sample constituents. Sample transport lines and system components must be heated sufficiently through their entire length to transport target compounds to the IR sample cell.

8.1.2 Select Spectroscopic Setup. Select a spectroscopic configuration for the application. Approximate the absorption pathlength, sample pressure, absolute sample temperature, and signal integration period necessary for the analysis. Specify the nominal minimum instrumental linewidth (MIL) of the system.

8.1.3 Analytical Program.

8.1.3.1 Prepare an analysis algorithm for acquired spectra. Use as input, reference spectra of all target analytes and expected interferents. Include reference spectra of additional interferent compounds in the program if their presence (even if transient) in the samples is considered possible. The program output must be in ppmv (or parts per billion by volume [ppbv]) and must correct for differences between the reference pathlength (L_R), temperature (T_R), and pressure (P_R), and the actual conditions used for collecting the sample spectra.

8.1.3.2 Choose a mathematical technique (e.g., classical least squares, partial least squares, inverse least squares) for analyzing spectral data by comparison with reference spectra.

8.1.3.3 Reference spectra incorporated in the program must either bracket the observed sample matrix concentration or use a direct injection to verify the calibration curve. Additionally, you must use a sufficient number (> 3) of reference spectra (or reference spectra plus direct injection checks for low concentration regimes) in the bracketed range to demonstrate linearity in that concentration range. Alternatively, if the matrix concentration is expected to be within three times the detection limit of this method, you may use calculated reference spectra (i.e., HITRAN or PNNL) at the lower end of the bracketing range.

8.1.3.4 Analysis regions selected for a target compound(s) must have an absorbance value of less than 1. You must select specific wavelengths in each region where the target analyte does not overlap with an interfering compound and use the selected wavelengths throughout the entire validation (section 9.4), QA spiking (section 11.4), and testing campaign.

8.2 Leak Check. To conduct the leak check, follow the procedures specified in section 11.1.

8.3 Detector Linearity. To verify detector linearity, follow the procedures specified in section 11.2.

8.4 Data Storage Requirements. For these requirements, follow the procedures specified in section 11.8.

8.5 Background Spectrum. Flow dry nitrogen through the gas cell and verify that no significant amounts of absorbing species are present. Collect a background spectrum, using a signal averaging period equal to or longer than that being used for averaging of source sample spectra. Assign a unique file name to the background spectrum.

8.6 Pre-Test Calibrations.

8.6.1 Calibration Transfer Standard. Flow the CTS gas through the cell and verify that the measured concentration is stable to within the uncertainty of the gas standard. Record the spectrum. Additionally, measure the linewidth of appropriate CTS band(s) to verify instrument resolution. Alternatively, compare CTS spectra to a reference CTS spectrum, if available, measured at the nominal resolution.

8.6.2 QA Spike. Conduct a QA spike per the instructions in section 11.4 of this method.

8.7 Sampling. See section 11.5 of this method. While sampling, monitor the signal transmittance. If the transmittance (relative to background) changes by 5% or more in any analytical spectral region, obtain a new background spectrum.

8.8 Post-Run CTS. After the sampling run, record another CTS spectrum.

8.9 Perform post-run QA per section 9.1.2 of this method.

9.0 *Quality Assurance and Quality Control*

9.1 Quality Assurance (QA).

9.1.1 Pre-Test QA.

9.1.1.1 Prior to testing, verify that the sample integration time is sufficient to achieve the required signal-to-noise ratio.

9.1.1.2 Assign a unique file name to each spectrum.

9.1.1.3 For reporting and recording requirements, see sections 11.6 and 11.7 of this method.

9.1.2 Post-Test QA.

9.1.2.1 Inspect the sample spectra immediately after the run to verify the gas matrix composition was close to the expected matrix composition.

9.1.2.2 Verify that the sampling and instrumental parameters were appropriate for the actual stack conditions. For example, if the moisture of the sampled gas was much higher than anticipated, a shorter pathlength cell or more dilute sample may be needed.

9.1.2.3 Compare the pre- and post-test CTS spectra. The peak absorbance in the pre- and post-test CTS must be $\pm 5\%$ of the mean value.

9.2 Quality Control (QC). The analyte spike procedure in section 9.3 of this method and the validation procedure in section 9.4 of this method are used to evaluate the performance of the sampling system and to quantify sampling system effects, if any, on the measured concentrations. This method is self-validating provided that the results meet the performance requirement of the QA spike in section 11.4 of this method.

9.3 Spike Procedure. Spiking must be done per a standard addition procedure consisting of measuring the source emissions concentration (i.e., native source gas concentration), addition of reference gas, and measurement of the resulting standard addition (SA) elevated source gas concentration. Spiking must be done dynamically accounting for the spike dilution of sample gas with the addition of the reference gas.

9.3.1 Each dynamic spike (DS) or SA replicate consists of a measurement of the source emissions concentration (native stack concentration) with and without the addition of the species of interest. With a single FTIR, you must alternate the measurement of the native and SA-elevated source gas so that each measurement of SA-elevated source gas is immediately preceded and followed by a measurement of native stack gas. Introduce the SA gases in such a manner that the entire sampling system is challenged. Alternatively, you may use an independent FTIR and sampling system to measure the native source concentration throughout each standard addition.

9.3.1.1 Pre and post-test spiking must consist of at least 3 replicates. A replicate is defined as the following measurement sequence: native gas concentration, SA-elevated gas concentration, native gas concentration. In addition to the pre-test spike instance, spiking must also be performed post-test.

9.3.1.2 It is recommended that spiking be performed after each run to ensure continued compliance with the required spike recovery criteria. If spiking is not performed after each run and the post-test spike fails, all data for that test are invalid. However, if spiking is performed after each run, data bracketed on each end by a successful spike are valid test data.

9.3.2 Your spike gas flow rate must not contribute more than 10% of the total volumetric flow rate through the FTIR.

9.3.3 Determine the response time (RT) of the system. First, inject zero air into the system. For standard addition RT determination, next measure the native stack concentration of the species to be spiked. The concentration has stabilized when variability appears constant for five minutes.

9.3.4 You must determine a dilution factor (DF) for each dynamic spike. Determine the DF via a tracer, and use the following equation for a source where the tracer is not native to the source emissions:

$$DF = \frac{M_{spiked\ tracer}}{C_{tracer\ spiked}} \quad \text{Equation 1}$$

Where:

$M_{spiked\ tracer}$ = the measured diluted tracer gas concentration in a spiked sample.

$C_{tracer\ spiked}$ = the tracer gas concentration injected with the spike gas.

Note: Use consistent concentration units for each variable in Equation 1.

In instances where the tracer gas is native to the source emissions, use the following equation:

$$DF = \frac{M_{spiked\ tracer} - M_{native\ tracer}}{C_{native\ tracer} - M_{native\ tracer}} \quad \text{Equation 2}$$

Where:

$M_{native\ tracer}$ = the measured tracer concentration present in the native effluent gas.

$C_{native\ tracer}$ = the undiluted tracer gas concentration in the cylinder.

Note: Use consistent concentration units for each variable in Equation 2.

9.3.4.1 Standard Addition Response. The standard addition response (SAR) represents the difference between the measured native source concentration and the concentration measured upon introduction of the standard addition (source + SA) via dynamic spike. Calculate the SAR via the following equation:

$$SAR = MC_{spiked} - (1 - DF) * MC_{native} \quad \text{Equation 3}$$

Where:

MC_{spiked} = the measured reference analyte concentration.

MC_{native} = the measured concentration of the analyte in the native effluent.

Note: Use consistent concentration units for each relevant variable in Equation 3.

9.3.4.2 Effective Spike Addition. The effective spike addition (ESA) is the expected increase in the measured concentration as a result of injecting a spike. For the section 11.4 QA spike, the ESA must be within 50% of the native stack concentration. Calculate the ESA with the following equation, for use when using a certified cylinder:

$$ESA = DF * (C_{spike} - MC_{native}) \quad \text{Equation 4}$$

Where:

C_{spike} = the certified reference analyte concentration.

When using a non-certified cylinder, replace the C_{spike} term in Equation 4, with MC_{spiked} .

Note: Use consistent concentration units for each relevant variable in Equation 4.

9.3.4.3 Spike Recovery. The degree to which the SAR and the ESA agree represents the spike recovery (SR), or the ability to measure the spiked analyte on top of the amount of that analyte native to the stack. Spike recovery is calculated according to the following equation:

$$SR = \frac{SAR}{ESA} \quad \text{Equation 5}$$

9.3.4.4 Spiking Procedure for Highly Variable Sources. In some instances, a source may be encountered that is too variable for the procedures listed in sections 9.3 and 11.4 of this method. A highly variable source, for which this procedure may be used is defined as a source that varies randomly and by more than 25% from data point to point, where two consecutive points are less than or equal to a minute apart. For these types of sources, the approach outlined in section 9.3.5.4.1 of this method may be used.

9.3.4.4.1 Dual FTIR and Extractive Systems Approach. This field approach is performed using two independent FTIRs and sample extraction systems that use tubing of the same length and diameter and that pull the sample at approximately the same flow rate. One FTIR characterizes the fluctuations of the target analyte(s) over time and the second FTIR performs the spike recoveries. Note that testers can use either a single probe attached to both systems or separate probes for each system with the probe tips co-located (within 6 inches) in the sample duct. In either case, it is mandatory for the spike to occur prior to the PM filter. Perform the spiking procedure as follows.

Note: This procedure assumes that the dilution factor is calculated as stated in EPA Method 320 or ASTM D6348-12e from either a spectroscopic tracer or metered flows.

9.3.4.4.1.1 After positioning the FTIR probes accordingly, begin pulling sample gas into both FTIR sample analysis cells. Use the same sampling period and the identical quantification method (i.e., same reference spectra for construction and the same regions for quantification) for each FTIR.

a. Sample the source gas stream for approximately 15 minutes, collecting at least 8 spectra on each FTIR.

b. Calculate the average concentration of the target analyte(s) for each FTIR. If the average concentrations determined using the two FTIRs are not within 10%, either the analysis routines were not identical, the timing was not consistent, or the sample system or FTIR cell in one of the FTIRs is reacting with the target analyte(s). Note: If the average concentrations are not within 10%, the spike recovery criterion will be more difficult to achieve.

9.3.4.4.1.2 If the average concentrations agree within 10%, begin flow of the analyte spike into one of the FTIRs. At this point, the spiked FTIR should have a consistent offset to the unspiked FTIR. After this offset is consistent, collect a minimum of 8 data points.

9.3.4.4.1.3 Calculate the difference between the average concentration of the spiked data and the average concentration of the unspiked data (i.e., the average concentration of the spike) using equation 6 of this method.

9.3.4.4.1.4 Calculate the recovery (equation 7) of the spike using the predicted spiked concentration by the dilution factor (as determined per the reference method used) and the resultant from Step 3 (equation 6).

$$SV = \frac{1}{n} \sum_{i=1}^n S_i - \frac{1}{p} \sum_{i=1}^p U_p \quad \text{Equation 6}$$

Where:

SV = Concentration of target analyte spiked into the extracted gas stream.

S_i = Individual concentration results from the spiked FTIR.

n = Number of individual spiked concentration measurements collected.

U_p = Individual concentration results from the unspiked FTIR (native gas concentration).

p = Number of individual, unspiked concentration measurements collected.

Note: Use consistent concentration units for each relevant variable in Equation 6.

$$\text{Recovery} = \left(\frac{SV}{(DF * \text{Spike Cylinder Concentration})} \right) \quad \text{Equation 7}$$

Where:

SV = Spiked concentration as calculated from Equation 6.

DF = Dilution Factor as determined from tracer in spike gas standard or from flows.

Spike Cylinder Concentration = Concentration of target analyte(s) from spike gas standard (e.g., determined from direct injection or from certified cylinder tag value).

Note: Use consistent concentration units for each relevant variable in Equation 7.

9.4 Method Validation Procedure.

This validation procedure, which is based on EPA Method 301 (40 CFR part 63, appendix A), must be used to validate this method for the analytes in a gas matrix. Analytes that have not been validated for a particular source type may not be measured using Method 320. Validation at one source may also apply to another type of source, if it can be shown that the exhaust gas characteristics are similar at both sources.

9.4.1 Use section 5.3 of Method 301 (40 CFR part 63, appendix A), the Analyte Spike procedure, with these modifications. The statistical analysis of the results follows section 6.3 of EPA Method 301. Section 3 of this method defines terms that are not defined in Method 301.

9.4.2 The analyte spike is performed dynamically. This means the spike flow is continuous and constant as spiked samples are measured.

9.4.3 Introduce the spike gas at the back of the sample probe.

9.4.4 Spiked effluent is carried through all sampling components downstream of the probe.

9.4.5 A single FTIR system (or more) may be used to collect and analyze spectra (not quadruplicate integrated sampling trains).

9.4.6 All of the validation measurements are performed sequentially in a single “run” (section 3.23 of this method).

9.4.7 The measurements analyzed statistically are each independent (section 3.22 of this method).

9.4.8 A validation data set must consist of 12 or more spike replicates.

10.0 Calibration and Standardization

10.1 Analytes. Select the required detection level (DL_i) and maximum permissible analytical uncertainty (AU_i) for each analyte (1 to i). The required DL must be equal to or greater than the method DL determined via section 13.1 of this method. Estimate, if possible, the maximum expected concentration for each analyte (C_{MAX_i}). The expected measurement range is then bounded by DL_i and C_{MAX_i} for each analyte.

10.2 Interferents. List all potential interferents applicable to your source matrix. Collect or obtain spectra of known and suspected interferences that were acquired using the same optical system that will be used in the field measurements. You may also use calculated spectra from sources such as HITRAN as long as the spectral resolution matches the resolution of source test sample spectra. These interferents must be included in the analytical algorithm used to fit FTIR spectra for quantitation.

10.3 CTS Absorption Bands. Absorption bands used for CTS quantitation must be at least ten times the root mean square (RMS) value of the noise equivalent absorbance (NEA) of a wavelength range nearest to that absorption band. This value, NEA_{RMS}^{CTS} can be determined as follows:

10.3.1 Determine the absolute noise equivalent absorption (NEA) for an analytical region by flowing nitrogen or zero air through the gas sample cell. The NEA is the peak-to-peak noise in a spectrum resulting from collection of two successive background spectra. Therefore, collect two background spectra in succession while the nitrogen or zero air is continuously flowing

through the cell. Note that the same averaging time must be used for NEA determination as will be used for actual sample collection.

10.3.2 Calculate NEA_{RMS}^{CTS} per the following equation:

$$NEA_{RMS}^{CTS} = \sqrt{\frac{1}{n} \sum_{j=1}^{N_{CTS}} (NEA_i^{CTS})^2} \quad \text{Equation 8}$$

where:

N_{CTS} = the number of absorbance points in the analysis region for the CTS.

NEA_i^{CTS} = the individual absorbance values of the noise spectrum in the analysis region, i.

10.4 Reference Spectra. Obtain reference spectra for each analyte, interferant, surrogate, CTS, and tracer.

10.4.1 The tester must report traceability and other pertinent information for each reference spectrum, for each compound, including: temperature, pressure, concentration, cylinder source and specifications, spectral regions of analysis used for quantitation (with specific wavelength ranges used), and calibration fit equations and correlations.

10.4.2 If commercially prepared, or other available reference libraries are used to quantify data, the FTIR spectral resolution and line position, cell pathlength, temperature and pressure, and apodization function must be known and reported. Resolution, line position, and apodization function used for collection of sample spectra must be the same as those of the reference spectra used for quantitation.

10.4.3 Reference spectra for each target compound must bracket the concentration of that compound in the sample stream.

10.4.3.1 In the case where traceable reference spectra provided by the FTIR manufacturer do not bracket the concentration of a particular compound, two options are available. A direct injection of the compound of interest (NIST traceable and certified to $\pm 5\%$) into the FTIR at a

concentration lower than that found in the sample stream and within three times the method detection level, may be performed to demonstrate the appropriateness of the calibration line at this level. To perform this check, while directly injecting the compound of interest into the FTIR, wait for the concentration of the compound to stabilize. Once stable, verify that the concentration as determined via the calibration curve is within 10% of the cylinder value or else do not proceed with testing.

10.4.3.2 Alternatively, calculated spectra, such as those from HITRAN or PNNL, may be used at the lower end of the bracketing range, within three times the method detection level, as well.

10.4.4 Collecting Reference Spectra. In some cases, it may be necessary for the tester to collect reference spectra prior to testing. The procedure found in this section is to be used in such a case.

10.4.4.1 Record a set of CTS spectra.

10.4.4.2 Collect a set of the reference spectra at two or more concentrations in triplicate over the desired concentration range. The top of the concentration range must be less than 10 times that of the bottom of the range.

10.4.4.3 Collect a second set of CTS spectra. The maximum accepted concentration for each compound shall be higher than the maximum estimated concentration for both analytes and known interferences in the effluent gas. For each analyte, the minimum accepted concentration shall be no greater than ten times the concentration-pathlength product of that analyte at its required detection limit.

10.4.4.4 Permanently store the background and interferograms digitally, and separately. Document details of the mathematical process (i.e., apodization function) for generating the spectra from these interferograms. Record sample pressure (P_r), sample temperature (T_r), reference absorption pathlength (L_r), and interferogram signal integration period (t_{sr}).

10.5 Absorption Cell Path Length Determination.

10.5.1 Flow the CTS through the FTIR cell. Once the absorbance of two consecutive spectra differ by less than or equal to the uncertainty of the cylinder standard, the CTS spectrum may be recorded. Note that the CTS gas must be one of the following gases: ethylene, methane, or carbon dioxide.

10.5.2 Record a set of the absorption spectra of the CTS, and record the temperature, pressure, and concentration of the CTS.

10.5.3 Record the instrument manufacturer's nominal absorption pathlength, nominal spectral resolution, and the CTS signal integration period.

10.5.4 Calculate the reference cell absorption pathlength, according to the following equation:

$$L_r = L_f \left(\frac{T_r}{T_f} \right) \left(\frac{P_f}{P_r} \right) \left(\frac{C_f}{C_r} \right) \left\{ \frac{A_r}{A_f} \right\} \quad \text{Equation 9}$$

where:

L_r = reference cell absorption pathlength.

L_f = fundamental CTS absorption pathlength.

T_r = absolute temperature of reference CTS gas.

T_f = absolute temperature of fundamental CTS gas.

P_r = absolute pressure of reference CTS gas.

P_f = absolute pressure of fundamental CTS gas.

C_r = concentration of the reference CTS gas.

C_f = concentration of the fundamental CTS gas.

$\{A_r/A_f\}$ = ratio of the reference CTS absorbance to the fundamental CTS absorbance, determined by classical least squares, integrated absorbance area, spectral subtraction, or peak absorbance techniques.

10.6 Instrument Resolution.

10.6.1 Flow ambient air through the gas cell.

10.6.2 Verify the instrument resolution using a water absorbance peak near either 1,918 cm^{-1} , 3,050 cm^{-1} , or 3,920 cm^{-1} .

10.6.3 The absorbance of the peak being used for the resolution determination should be approximately 0.25 absorbance units. Mix additional humidified air or nitrogen with the ambient flow, to achieve this absorbance.

10.6.4 Record an absorbance spectrum and measure the FWHH of the chosen water peak. The measured FWHH of the water peak must be within 5% of the nominal instrument resolution to proceed with testing.

11.0 Method Procedures

11.1 Leak Check. Verify that there are no significant vacuum-side leaks using one of the leak tests described in this section. Perform the vacuum-side leak check after each installation at the sampling or measurement location. Leak check must be performed prior to the start of the field test, and after any relocation or maintenance to the sample transport system. A leak may be detected either by measuring a small amount of flow when there should be zero flow, or by measuring the vacuum decay rate. To test for leaks using loss of vacuum you must know the vacuum-side volume of your sampling system to within $\pm 10\%$ of its true volume.

11.1.1 Low-Flow Leak Test. Test a sampling system for leaks using low-flow measurements as follows:

11.1.1.1 Seal the probe end of the system by capping or plugging the end of the sample probe.

11.1.1.2 Start sampling pumps and operate them until the pressure stabilizes.

11.1.1.3 Observe/measure the flow through the vacuum-side of the sampling system. A flow of less than 0.5% of the system's normal in-use flow rate is acceptable.

Note: For bypass systems, where the sample flow rate through the vacuum side of the sample system is greater than the FTIR cell flow rate, the higher flow rate (bypass plus analyzer/FTIR flow rate) is used as the in-use flow rate when calculating acceptability of the leak level.

11.1.2 Vacuum-Decay Leak Test. Perform a vacuum-decay leak test as follows:

11.1.2.1 Seal the probe end of the system as close to the probe opening as possible by capping or plugging the end of the sample probe.

11.1.2.2 Operate all vacuum pumps. Draw a vacuum on the sampling system and let the pressure on the system stabilize.

11.1.2.3 Turn off the sample pumps and seal the system under a vacuum of 250 mmHg greater than the source static pressure. Record the absolute pressure and the system absolute temperature every 30 seconds for 5 minutes. The leak rate must be equal to or less than 2.5 mmHg per minute.

11.2 Detector Linearity. Observe the single beam instrument response in the frequency region below the detector cutoff (usually $< 400 \text{ cm}^{-1}$), where the detector response is known to be zero. Verify that the detector response is “flat” and equal to zero in this region, or at least 100 times less than the peak signal in the entire spectrum. If the response is not linear, decrease the aperture or attenuate the IR beam, and repeat the linearity check until the detector response is linear.

11.3 Gas Cell Pathlength. Verify the gas cell pathlength of your instrument by following the procedure found in section 10.6.4 of this method.

11.4 QA Spike. This procedure assumes that the method has been validated for each of the target analytes at the source. Choose one of two options and perform the standard addition procedure listed in section 9.3 of this method.

Note: For unstable sources, QA spiking may be difficult. An alternative procedure for such a source is described in section 9.3.5.4.

11.4.1 QA Spike Option 1. Use a certified standard ($\pm 2\%$ accuracy) for an analyte that has been validated at the source. One may either spike each analyte of interest or choose an appropriate surrogate. An appropriate surrogate must have a vapor pressure that is less than or equal to the analyte of interest and be less soluble in water. The wavelength at which the surrogate is to be quantified must be reported and be within 100 wavenumbers of a wavenumber that will be used to quantify the analyte of interest. Additionally, the pKa of a surrogate must be within 20% of the pKa of the analyte of interest. Surrogates are not allowed for the following analytes: formaldehyde, HCl, HF, NH₃, and vinyl chloride. If the spike recovery, as calculated by Equation 5 of this method, is within 70 -130% then proceed with the testing.

11.4.2 QA Spike Option 2. Use a non-certified cylinder for an analyte that has been validated at the source. As with Option 1, one may either spike each analyte of interest or choose an appropriate surrogate. If the spike recovery, as calculated by equation 5 of this method, is within 90 -110%, then proceed with the testing.

11.5 Sampling. Sampling must be done using a continuous flow of source gas.

11.5.1 Stratification Check. A stratification check must be performed, per the steps in this section, to justify sampling at a single location during testing.

11.5.1.1 Use a probe of appropriate length to measure the analyte of interest at each of 12 traverse points (MN_i , where $i = 1$ to 12) located according to section 11.3 of Method 1 in appendix A-1 to 40 CFR part 60 for a circular stack or nine points at the centroids of similarly shaped, equal area divisions of the cross section of a rectangular stack.

11.5.1.2 Calculate the mean measured concentration for all sampling points (MN_{avg}).

11.5.1.3 Calculate the percent stratification (S_i) of each traverse point using the following equation:

$$S_{ti} = \frac{MN_i - MN_{avg}}{MN_{avg}} * 100 \quad \text{Equation 11}$$

11.5.1.4 The gas stream is considered to be unstratified and you may perform testing at a single point that most closely matches the mean if the concentration at each traverse point differs from the mean concentration for all traverse points by no more than 5.0% of the mean concentration.

11.5.1.5 If the criteria for single point sampling is not met, but the concentration at each traverse point differs from the mean concentration by no more than 10% of the mean, the gas stream is considered minimally stratified, and you may sample using the “3-point short line.”

11.5.1.6 If the concentration at any traverse point differs from the mean by more than 10%, the gas stream is considered stratified, and you must sample using the stratification check procedure specified in section 11.5.1.1 of this method.

11.5.2 Assign a unique filename to each spectrum and separately to each corresponding interferogram. Spectra and interferograms must be providable in “.spc” format upon request.

11.5.3 Temperature. The temperature of the gas cell must be measured directly. The temperature measurement device must be calibrated to within $\pm 0.1^{\circ}\text{C}$ every 12 months.

11.5.4 Pressure. The gas cell pressure must be measured empirically. The measurement device must be calibrated to within ± 1 mmHg every 12 months.

11.5.5 Inspect the sample spectra immediately after the run to verify that the gas matrix composition was close to the expected (assumed) gas matrix. Additionally, look at the residual spectra for each sample spectrum to confirm interferences have been accounted for.

11.6 Post-Test CTS. At the end of each test, record another CTS spectrum. Compare the pre- and post-test CTS spectra. The peak absorbance in pre- and post-test CTS must be $\pm 5\%$ of the mean value.

11.7 Record and Report.

11.7.1 The following must be documented and reported for each sample spectrum: sampling conditions, sampling time (# of scans per average and amount of time per scan),

instrumental conditions (pathlength, temperature, pressure, resolution, laser frequency, instrument make and model), and spectral filename.

11.7.2 Test Report. You must prepare a test report following the guidance in EPA Guidance Document 043 (Preparation and Review of Test Reports. December 1998). Additional minimum reporting requirements are listed here:

11.7.2.1 Instrument and sampling system related items.

- a. Instrument make and model.
- b. Sampling line length, material, and temperature.
- c. Instrument resolution.
- d. Cell pathlength, pressure, and temperature.
- e. Laser frequency.
- f. Cylinder regulator type.

11.7.2.2 Software/Algorithm related items.

- a. Gases included in the analysis (interferences + analytes of interest).
- b. Concentration values of reference spectra, as well as temperature and pressure information for all interferences and analytes of interest.
- c. Analysis wavelength regions for each compound (interferences + analytes of interest).

11.7.2.3 CTS, QA/QC and validation related items.

- a. A list of compounds that are being spiked. Note that Method 320 allows for use of qualified surrogates. Qualified surrogates should be appropriate for the compound actually being measured. It is preferable that the compound of interest always be spiked if it is available as a certified standard.
- b. Is/are the spike(s) being performed dynamically?
- c. Are spikes being introduced at the back of the sample probe and travelling through the entire sampling system?

- d. Are standards being used for QA spiking of appropriate quality? For example, (+/- 2% for Protocol gases where available and +/- 5% for other certified gases?
- e. Has FTIR been validated for the source under consideration?

11.8 Digital Data Storage. All field test data must be electronically stored, readily available, and provided to the regulatory authority upon request. Stored information must include: sample interferograms, background interferograms, CTS sample interferograms, processed sample absorbance spectra, and processed CTS absorbance spectra.

12.0 Data Analysis and Calculations

12.1 Analyte concentrations must be measured using reference spectra as they are described in section 10.5 of this method. Use the algorithm developed in section 8.3 of this method to calculate the concentration of each species in the sample matrix as well as their respective residuals. Classical least squares, augmented classical least squares, or partial least squares algorithms must meet the following criteria:

12.1.1 The algorithm must be capable of correcting for differences in gas cell pathlength, temperature, and cell pressure between sample and reference spectra. If the algorithm does not have this capability, perform this correction using equation 12:

$$C_{corr} = \left(\frac{L_r}{L_s}\right)\left(\frac{T_s}{T_r}\right)\left(\frac{P_r}{P_s}\right)C_{calc}$$

Equation 12

12.1.2 The algorithm must be capable of reporting spectral residuals for all compounds being analyzed as a function of its spectral fit using the techniques in section 11.1 of this method.

13.0 Method Performance

13.1 Detection Level (DL). The DL of this method is defined as the SAR value where the SAR is greater than three times the residual value of the corresponding standard addition elevated concentration (MC_{spiked}). The DL for this method must be less than or equal to 20% of the

applicable compliance limit for the compound being measured. If this is not the case, Method 320 cannot be used for such an application.

13.2 Background Deviation. Deviations in absorption greater than $\pm 5\%$ in an analytical region are unacceptable, and Method 320 cannot be used under this condition.

14.0 Pollution Prevention

The extracted sample gas is vented outside the enclosure containing the FTIR system and gas manifold after the analysis. In typical method applications, the vented sample volume is a small fraction of the source volumetric flow and its composition is identical to that emitted from the source. When analyte spiking is used, spiked pollutants are vented with the extracted sample gas. Minimize emissions by keeping the spike flow off when not in use.

15.0 Waste Management

Small volumes of laboratory gas standards can be vented through a laboratory hood. Neat samples must be packed and disposed of according to applicable regulations. Surplus materials may be returned to supplier for disposal.

16.0 References

1. Protocol for the Use of Extractive Fourier Transform Infrared (FTIR) Spectrometry in Analyses of Gaseous Emissions from Stationary Sources, <https://www3.epa.gov/ttn/emc/ftir/FTIRProtocol.pdf>.
2. U.S. EPA. Method 301—Field Validation of Pollutant Measurement Methods from Various Waste Media, 40 CFR part 63, appendix A.
3. EPA Traceability Protocol for Assay and Certification of Gaseous Calibration Standards, <https://www.epa.gov/air-research/epa-traceability-protocol-assay-and-certification-gaseous-calibration-standards>.

17.0 Tables, Diagrams, Flowcharts, and Validation Data

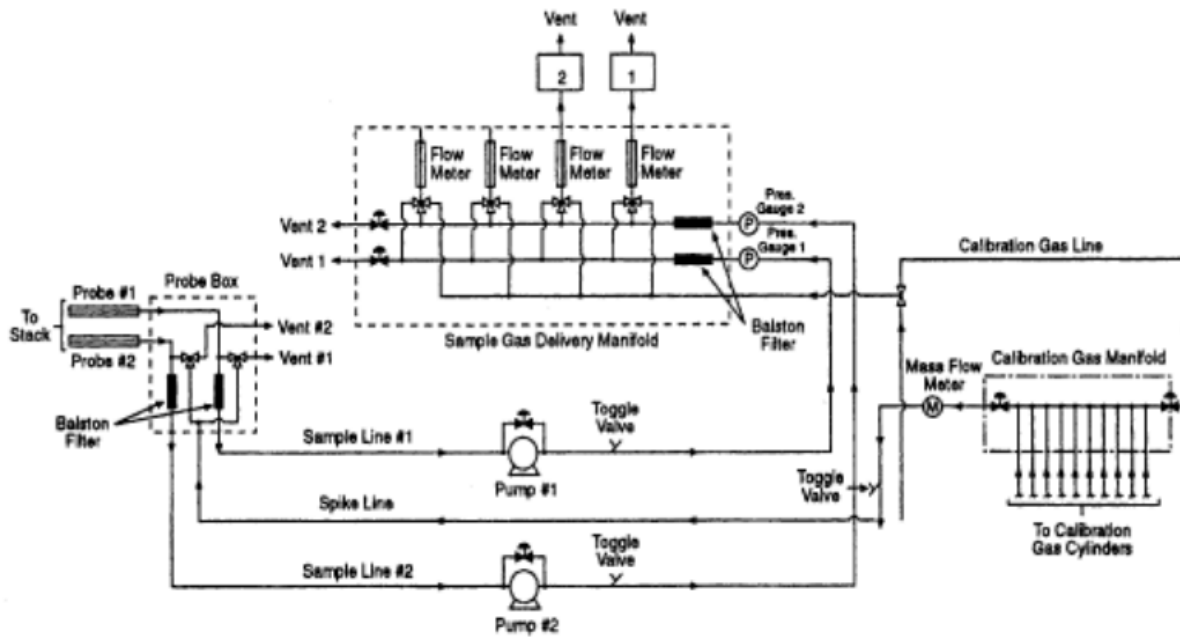

Figure 1. Schematic of FTIR Sampling System

* * * * *

[FR Doc. 2024-04359 Filed: 2/29/2024 8:45 am; Publication Date: 3/1/2024]