



DEPARTMENT OF TRANSPORTATION

National Highway Traffic Safety Administration

49 CFR Part 571

Docket No. NHTSA-2023-0040

RIN 2127-AL34

Federal Motor Vehicle Safety Standards: Child Restraint Systems

AGENCY: National Highway Traffic Safety Administration (NHTSA), Department of Transportation (DOT).

ACTION: Final rule.

SUMMARY: This final rule amends a Federal Motor Vehicle Safety Standard (FMVSS) regarding child restraint systems. The amendments, mandatory in one year, modernize the standard by, among other things, updating CRS owner registration program requirements, labeling requirements on correctly using child restraints, requirements for add-on school bus-specific child restraint systems, and provisions for NHTSA's use of test dummies in NHTSA compliance tests. Amendments mandatory in three years include adding a new FMVSS that updates to standard seat assemblies on which NHTSA tests child restraint systems for compliance with frontal crash performance requirements. This final rule fulfills a mandate of the Moving Ahead for Progress in the 21st Century Act (MAP-21) that directs NHTSA to update the standard seat assembly. The purpose of this final rule is to ensure continued effectiveness of child restraint systems in current and future vehicles.

DATES: *Effective date:* February 5, 2024.

IBR date: The incorporation by reference of certain publications listed in the rule is approved by the Director of the Federal Register as of February 5, 2024. The incorporation by

reference of certain other publications listed in the rule was approved by the Director as of February 6, 2012.

Compliance date: The compliance date for the amendments to FMVSS No. 213 is December 5, 2024. The compliance date for meeting FMVSS No. 213b is December 5, 2026. Optional early compliance with the standards is permitted.

Reconsideration date: If you wish to petition for reconsideration of this rule, your petition must be received by January 19, 2024.

ADDRESSES: Petitions for reconsideration of this final rule must refer to the docket and notice number set forth above and be submitted to the Administrator, National Highway Traffic Safety Administration, 1200 New Jersey Avenue SE, Washington, DC 20590. Note that all petitions received will be posted without change to <https://www.regulations.gov>, including any personal information provided.

Confidential Business Information: If you wish to submit any information under a claim of confidentiality, you should submit your complete submission, including the information you claim to be confidential business information, to the Chief Counsel, NHTSA, at the address given under **FOR FURTHER INFORMATION CONTACT**. In addition, you should submit a copy, from which you have deleted the claimed confidential business information, to Docket Management at the address given above. When you send a submission containing information claimed to be confidential business information, you should include a cover letter setting forth the information specified in our confidential business information regulation (49 CFR part 512). Please see further information in the Regulatory Notices and Analyses section of this preamble.

Privacy Act: The petition will be placed in the docket. Anyone is able to search the electronic form of all documents received into any of our dockets by the name of the individual submitting the comment (or signing the comment, if submitted on behalf of an association, business, labor union, etc.). You may review DOT's complete Privacy Act Statement in the Federal Register published on April 11, 2000 (Volume 65, Number 70; Pages 19477-78) or you

may visit <https://www.transportation.gov/individuals/privacy/privacy-act-system-records-notices>.

Docket: For access to the docket to read background documents or comments received, go to www.regulations.gov, or the street address listed above. Follow the online instructions for accessing the dockets.

FOR FURTHER INFORMATION CONTACT: For technical issues, you may call Cristina Echemendia, Office of Crashworthiness Standards (telephone: 202-366-6345). For legal issues, you may call Deirdre Fujita or Matthew Filpi, Office of Chief Counsel (telephone: 202-366-2992). Address: National Highway Traffic Safety Administration, U.S. Department of Transportation, 1200 New Jersey Avenue, S.E., West Building, Washington, D.C. 20590.

SUPPLEMENTARY INFORMATION: This final rule amends FMVSS No. 213, “Child restraint systems,” and adds FMVSS No. 213b, “Child restraint systems; Mandatory applicability beginning December 5, 2026.” The amendments to FMVSS No. 213, mandatory in one year, modernize the standard by, among other things, updating CRS owner registration program requirements, labeling requirements on correctly using child restraints, requirements for add-on school bus-specific child restraint systems, and provisions for NHTSA’s use of test dummies in NHTSA compliance tests. FMVSS No. 213b, mandatory in three years, includes those amendments and updates the standard seat assembly on which NHTSA tests child restraint systems for compliance with frontal crash performance requirements. This final rule fulfills a MAP-21 that directs NHTSA to update the standard seat assembly. The purpose of this final rule is to ensure continued effectiveness of child restraint systems in current and future vehicles.

Table of Contents

I. Executive Summary

II. Safety Need and NHTSA Strategies

a. 2020 Fatalities

b. NHTSA Strategies

1. Increase CRS Use

2. Increase Correct Use

3. Strengthen FMVSS No. 213 and Address Safety Defects

III. Statutory Authority

IV. Guiding Principles

V. Overview of the NPRM and Comments Received

VI. Updating the Representative Standard Seat Assembly

- a. Seat Geometry
 - 1. Seat Back Angle
 - 2. Seat Pan Angle
 - 3. Seat Pan Length
 - 4. Seat Back Height

- b. Rear Seat Cushion Characteristics
 - 1. Thickness--Seat Back Cushion
 - 2. Thickness--Seat Bottom Cushion
 - 3. Foam Stiffness
 - 4. Miscellaneous Issues

- c. Means for Attaching a CRS
 - 1. Seat Belts
 - 2. Child Restraint Anchorage System

- d. Repeatability and Reproducibility of Test Results

- e. Miscellaneous Issues
 - 1. Addition of a Rebound Support Surface
 - 2. Truncating Head Acceleration Time Histories
 - 3. Drawing Changes

- f. Why NHTSA Has Not Adopted a Floor (Reiteration)

VII. Retaining the Type 1 (Lap Belt) Installation Requirement

- a. CRSs for Use in Older Vehicles
- b. Installing Harnesses

VIII. Communicating with Today's Caregivers

- a. The CRS Owner Registration Program
 - 1. Background
 - 2. Comments to the NPRM and NHTSA's Responses
 - 3. Other Issues
 - 4. Summary

- b. Information on Correctly Using CRSs
 - 1. Background
 - 2. Labeling by Mode Use
 - 3. Increasing the Forward-Facing Weight Recommendation
 - 4. Increasing the Belt-Positioning Seat Weight Recommendation
 - 5. Suggested Additional Booster Seat Labeling
 - 6. Other Recommendations About Labels
 - 7. Summary

IX. Streamlining NHTSA’s Use of Dummies in Compliance Tests to Reflect CRS Use Today

- a. Introduction
- b. Testing CRSs for Children Weighing 10 - 13.6 kg (22 - 30 lb)
- c. Testing CRSs for Children Weighing 13.6 – 18.2 kg (30 - 40 lb)
- d. Testing CRSs for Children Weighing 18 - 29.5 kg (40 - 65 lb) --Use of the HIII-6YO Dummy
- e. Positioning the Legs of the HIII-3YO Dummy in CRSs Used Rear-Facing
- f. Test Procedure Issues Raised by Commenters
- g. Table Summarizing Dummy Selection Criteria

X. School Bus Child Restraint Systems

XI. Corrections and Other Minor Amendments

- a. Corrected Reference
- b. Section 5.1.2.2, Section 5.4.1.1, and Figure 2
- c. Table to S5.1.3.1(a) and Test Configuration II
- d. Updating Reference to SAE Recommended Practice J211/1
- e. Section S5.9(a)
- f. Table S5.3.2
- g. Tether Tension Range
- h. Clarifying the FMVSS No. 213a and the 40 lb Cut Off

XII. Beyond the Scope of the Rulemaking

XIII. Child Passenger Safety Issues Arising from Research Findings

- a. CRSs Associated with Submarining or Ejection
- b. Should Infant Carriers’ Height Limits Better Align with Their Weight Limits?
- c. Virtual Models for CRS Fit

XIV. Lead Time and Compliance Dates

XV. Regulatory Notices and Analyses

XVI. Appendices to the Preamble

I. Executive Summary

This final rule amends FMVSS No. 213, “Child restraint systems,”¹ and adds FMVSS No. 213b, “Child restraint systems; Mandatory applicability beginning December 5, 2026.” The amendments to FMVSS No. 213, mandatory in one year, modernize the standard by updating the CRS owner registration program, labeling requirements instructing consumers on correct use of

¹ 49 CFR 571.213, “Child restraint systems.” All references to subparagraphs in this preamble are to FMVSS No. 213 unless otherwise noted.

child restraints, requirements for add-on school bus-specific child restraint systems, and provisions for NHTSA's use of test dummies in NHTSA compliance tests. FMVSS No. 213b, mandatory on December 5, 2026, includes those requirements and updates the standard seat assembly on which NHTSA tests child restraint systems for compliance with frontal crash performance requirements. In updating the standard seat assembly, this final rule fulfills a statutory mandate set forth in MAP-21 directing the Secretary of Transportation (NHTSA by delegation) to amend the standard seat assembly specifications in FMVSS No. 213 to better simulate a single representative motor vehicle rear seat.

NHTSA has amended FMVSS No. 213 and issued FMVSS No. 213b for plain language reasons relating to the compliance dates of the amendments. This final rule includes amendments that can be implemented in one year, which NHTSA has set forth in the amended FMVSS No. 213. The change to the standard seat assembly is incorporated in FMVSS No. 213b, which the agency is providing a three-year lead time for implementation. Because this final rule has a number of different compliance dates for the amendments to FMVSS No. 213 and the incorporation of the new standard seat assembly, and permits optional early compliance with the rule, the regulatory text would be highly complex if the amendments were combined, and effective dates parceled out, in a single standard. NHTSA decided the requirements would be easier to read and understand if the agency issued amendments becoming effective in one year in FMVSS No. 213, and established FMVSS No. 213b to include those FMVSS No. 213 amendments and the standard seat assembly requirements that become effective in three years.

Accordingly, FMVSS No. 213 applies to CRSs manufactured before December 5, 2026. FMVSS No. 213b applies to CRSs manufactured on or after December 5, 2026. FMVSS No. 213 will sunset when FMVSS No. 213b becomes mandatory in three years.

Overview of this Final Rule

NHTSA published the notice of proposed rulemaking (NPRM) preceding this final rule on November 2, 2020 (85 FR 69388, Docket No. NHTSA-2020-0093). This final rule adopts

almost all the proposals in the NPRM, with some adjustments in response to comments. There were 29 comments to the docket. The NPRM generally received wide support from commenters. We point out the main subjects of this final rule below. The goal of this rule is to ensure the continued effectiveness of CRSs in current and future vehicles, thereby reducing the unreasonable risk of fatality and injury to children in motor vehicle crashes.

1. As directed by § 31501(b) of MAP-21, NHTSA amends the standard seat assembly (S6.1.1(a)(1)(ii)) so that it more closely resembles “a single representative motor vehicle rear seat.” The updated seat has seat cushions (consisting of foam and a cover), a specified geometry, and a child restraint anchorage system² and seat belt systems for attaching child restraints. The seat belts are a Type 2 seat belt, also known as a lap/shoulder or 3-point seat belt, and a Type 1 (lap seat belt) system. In response to comments, this final rule fine-tunes some features of the updated standard seat assembly and updates some test procedures to reduce potential sources of variability.

2. Under this final rule, NHTSA will test child restraint systems with internal components³ that restrain the child for compliance while the CRS is attached to the updated standard seat assembly with a Type 2 belt.⁴ However, in response to comments, the rule retains until September 1, 2029, the requirement that these CRSs must meet the standard’s requirements when attached to the updated standard seat assembly with a Type 1 belt (S5.3.2).⁵ This provision will provide time for on-road vehicles to change over to a passenger vehicle fleet that will have Type 2 belts in nearly all rear seats. The purpose of this requirement is to ensure the continued

² Commonly called “LATCH,” which refers to Lower Anchors and Tethers for Children, a term industry developed to refer to the child restraint anchorage system required by FMVSS No. 225 for motor vehicles (49 CFR 571.225, “Child restraint anchorage systems”). A child restraint anchorage system consists of two lower anchorages, and one upper tether anchorage. Each lower anchorage includes a rigid round rod, or “bar,” onto which a hook, a jaw-like buckle or other connector can be snapped. The bars are located at the intersection of the vehicle seat cushion and seat back. The upper tether anchorage is a ring-like object, bar or webbing loop to which the upper tether of a child restraint system can be attached. FMVSS No. 213 requires CRSs to be equipped with attachments that enable the CRS to attach to the vehicle’s child restraint anchorage system.

³ These internal components that restrain the child can be an internal harness, a fixed surface, or a movable surface.

⁴ They are also subject to testing while attached with components of the LATCH system, which is a requirement previously established in FMVSS No. 213.

⁵ “Type 1” and “Type 2” seat belt assemblies are defined in FMVSS No. 209, “Seat belt assemblies.”

availability of CRSs that can be used in older model vehicles that only have Type 1 belts in rear passenger designated seating positions. Further, harnesses will continue to be tested only with a Type 1 belt, and this requirement will not sunset.⁶

3. This final rule reduces the restrictions on the content and format of the CRS owner registration form manufacturers must provide with new CRSs for purposes of direct recall notifications (S5.8). The amendment will make it easier for parents and caregivers to register CRSs with manufacturers. It makes FMVSS No. 213 more responsive to the communication preferences and practices of today's parents and provides greater flexibility to manufacturers in responding to those preferences. The intent is to increase recall remedy rates.

4. This final rule amends FMVSS No. 213's labeling requirements so that manufacturers have more flexibility in informing parents how to correctly use child restraints (S5.5), provided the following limits and all other labeling requirements are met. It directs manufacturers to label CRSs with information on the maximum height and weight of the children who can safely occupy the system (S5.5.2(f)) *for each mode* in which the CRS can be used (rear-facing, forward-facing, booster). This is a change from the current requirement which only requires manufacturers to provide an overall weight and height of the children who can occupy the CRS. This final rule also specifies that the forward-facing mode of a CRSs that can be used forward-facing may only be recommended⁷ for children with a minimum weight of 12 kg (26.5 lb). The minimum weight of 12 kg (26.5 lb) is an increase over the current threshold of 9 kg (20 lb) (S5.5.2(k)(2)). The weight threshold of 12 kg (26.5 lb) is the weight of a 95th percentile one-year-old.⁸ Thus, for example, for convertible⁹ child restraints systems, a manufacturer must use a

⁶ A "harness" is defined in Standard 213 as a combination pelvic and upper torso child restraint system that consists primarily of flexible material, such as straps, webbing or similar material, and that does not include a rigid seating structure for the child (S4).

⁷ When we describe a child restraint as "recommended for" or "labeled for" children of a certain height or weight range, we mean the child restraint manufacturer is selling, marketing, labeling or otherwise describing the CRS as suitable for children in that height or weight range.

⁸ A 50th percentile 1-year-old weighs 9.9 kg (22 lb).

⁹ A convertible CRS is a type of CRS with an internal harness to secure the child that can be used rear-facing and forward-facing. It is used rear-facing with infants (or small toddlers if the CRS weight recommendations allow it), and, forward-facing with older and larger children. The CRS manufacturer instructs the consumer when to turn the convertible CRS around to face forward, based on the weight of the child ("turnaround" weight).

turnaround weight of not less than 12 kg (26.5 lb). This change will increase the number of children under age 1 transported rear-facing, which is critical to child safety. Children under age 1 must be transported rear-facing because, until at least age 1, their neck is not developed enough to withstand crash forces imposed by their head when positioned forward-facing in a frontal crash. When riding rear-facing, they can take the brunt of the crash forces through their back, which is stronger than the neck.

Further, this rule specifies that booster seats may only be recommended for children with a minimum weight of 18.4 kg (40 lb), which increases the current threshold of 30 lb (S5.5.2(k)(2)).¹⁰ This change increases the likelihood that 3- and 4-year-olds will be transported in CRSs with an internal harness which better protects them at that young age than booster seats.¹¹ Children will still transition to booster seats, but just when they are a little larger. The purpose of these labeling provisions is to increase the likelihood that caregivers will use CRSs in the safest possible ways.

5. This final rule makes the following changes to simplify and make more representative the agency's use of test dummies in compliance tests (S7). For a CRS recommended for use rear-facing by children weighing 10 kg to 13.6 kg (22 to 30 lb), it will be subject to NHTSA testing while rear-facing with just the 12-month-old child test dummy (Child Restraint Air Bag Interaction (CRABI-12MO)) and will no longer be subject to rear-facing tests with the Hybrid III 3-year-old (HIII-3YO) test dummy.¹² This change better aligns the dummy used in tests of infant carriers¹³ with the size and weight of children typically restrained in infant carriers.

¹⁰ An 18.4 kg (40 lb) threshold corresponds generally to the weight of a 97th percentile 3-year-old (17.7 kg (39.3 lb)) and an 85th percentile 4-year-old.

¹¹ Booster seats are and continue to be a critical type of child restraint needed to restrain children properly in vehicles. As noted earlier, NHTSA instructs caregivers that children should be restrained in a CRS for the child's age and size. From birth through adulthood, children should be restrained first using a CRS used rear-facing, then a forward-facing CRS, then a booster seat, and finally, the vehicle's seat belts. <https://www.nhtsa.gov/equipment/car-seats-and-booster-seats#age-size-rec>

¹² Dummy selection is also done by height. Details of the dummy selection is discussed later in the preamble. See Table 13 of this preamble.

¹³ An infant carrier is a rear-facing CRS designed to be readily used in and outside of the vehicle. It has a carrying handle that enables caregivers to tote the CRS plus child outside of the vehicle. Some come with a base that stays inside the vehicle onto which the carrier attaches.

This rule also specifies that CRSs labeled for children weighing 13.6 kg to 18.2 kg (30 to 40 lb) will not be tested with the 22 lb CRABI-12MO.¹⁴ This change makes NHTSA’s compliance tests more reflective of real-world CRS use, as discussed in sections below (Section IX.b). This final rule adopts the proposed procedure for positioning the 3-year-old child test dummy’s legs when the dummy is rear-facing. The procedure is similar, if not identical, to that currently used by many manufacturers. For CRSs recommended for children in the 18.2 kg to 29.5 kg (40 to 65 lb) weight range, NHTSA amends FMVSS No. 213 to specify testing solely with the Hybrid III-6-year-old (HIII-6YO) child dummy and no longer with the older Hybrid 2 version of the dummy (H2-6YO). The purpose of these amendments is to heighten the assessment of CRS performance in protecting a child occupant.

6. This final rule amends FMVSS No. 213 to permit more types of add-on¹⁵ CRSs specially designed for exclusive use on school buses than currently permitted. The intent is to facilitate the availability of child restraints that are only used on school buses.

How this Final Rule Differs From the NPRM

For the convenience of the reader, we highlight below the noteworthy differences between the NPRM and this final rule. More minor changes are not highlighted here but are discussed in the sections relevant to the topic (e.g., use of a lap shield when using the HIII-6YO weighted dummy in belt-positioning seats). All amendments are discussed in the appropriate sections of this preamble.

The final rule differs from the 2020 NPRM by:

- Making minor changes (many of which were suggested by commenters) to the proposed standard seat assembly design (specifying stronger parts, tolerances, etc.) to strengthen its design and remove potential sources of variability;

¹⁴ If the CRS were also labeled as suitable for use by children weighing less than 13.6 kg (30 lb), then the CRS would be subject to testing with the CRABI-12MO. Dummy selection is also done by height. Details discussed later in the preamble.

¹⁵ “Add-on child restraint system” is defined in S4 of FMVSS No. 213 as “any portable child restraint system.”

- Making conforming changes and corrections to the drawing package for the updated standard seat assembly;
- Retaining the current requirement that child restraint systems be capable of anchoring to a vehicle seat by way of a Type 1 (lap) belt until September 1, 2029, to ensure the availability of CRSs to parents and caregivers that have older model vehicles;
- Retaining a provision in FMVSS No. 213 that child harnesses will be tested with a Type 1 seat belt installation; and,
- Not adopting a provision to use the 12-month-old CRABI (CRABI-12MO) dummy when testing child restraints that can be used in a forward-facing mode, provided that when the CRS is recommended for use forward-facing, it is recommended forward-facing only with children weighing a minimum of 12 kg (26.5 lb).

Estimated Benefits and Costs

This final rule provides safety benefits, with some temporary costs and long-term savings. The agency estimates potentially 0.7 to 2.3 lives will be saved and 1.0 to 3.5 moderate-to-critical severity injuries prevented with some labeling changes in this final rule. NHTSA cannot quantify the possible safety benefits of some amendments to the standard at this time. NHTSA estimates a one-time cost of \$9,300 for each manufacturer that chooses to purchase or produce an updated standard seat assembly. This cost impact is considered minimal when distributed among the hundreds of thousands of CRSs that will be sold by each manufacturer. There is a temporary (3 years) additional yearly cost for testing CRSs with Type 1 seat belts of \$5,198,000. NHTSA also estimates annual test cost savings of \$3,091,200 for the current number of infant carrier models (10 kg to 13.6 kg (22 to 30 lb)) in the market that will no longer be tested with the HIII-3YO and the CRSs that can be used forward-facing that will no longer be tested with the CRABI-12MO. This is a net annual cost increase of \$2,116,100 for each of the first three years and a net annual cost savings of \$3,091,200 per year after the first three years.

Updating the Standard Seat Assembly and Testing with Type 2 Belts

The updates to the sled test and testing with Type 2 belts better aligns the performance of CRSs in compliance tests to that in real world crashes. NHTSA believes there would be benefits from making the FMVSS No. 213 standard seat assembly more representative of vehicle rear seats, but quantification of the associated benefits/costs is not possible at this time due to a lack of data to make such an assessment.

There are only minimal costs involved in changing to the updated standard seat assembly used by NHTSA to assess CRS compliance. Manufacturers are not required to use the updated standard seat assembly, but as a practical matter they usually choose to do so. The one-time cost of the updated standard seat assembly sled buck is about \$9,300. Whether a manufacturer chooses to build the updated standard seat assembly itself or uses one at an independent test facility, cost impacts are minimal when distributed among the hundreds of thousands of CRSs that will be sold by each manufacturer. We are retaining the Type 1 belt test for an additional 3 years (2029) so there will temporarily be additional annual test costs of \$5,198,000 for testing with the Type 1 belt up to the year 2029.

NHTSA estimates that there will be little or no increased costs to child restraint systems to meet FMVSS No. 213's requirements when tested on the updated standard seat assembly. The agency's test data of representative CRSs in the fleet show that virtually all CRSs would meet the standard's requirements when tested on the updated standard seat assembly.

CRS Owner Registration Program

The changes to the registration form provide flexibility to manufacturers in how they communicate with consumers and will likely help improve registration rates and recall completion rates. However, NHTSA cannot quantify the benefits at this time. The agency estimates there would be no costs associated with the changes as they lessen restrictions and are optional for manufacturers to implement if their registration forms comply with current requirements. While the changes could affect the collection of information pursuant to the Paperwork Reduction Act (discussed later in this preamble), there will be no additional material

cost associated with the changes to the registration form. Manufacturers could use the same cards and just change the wording on them.

Labeling

The agency believes that the updates to the labeling requirements will benefit safety by reducing the premature transition of children from CRSs that can be used rear-facing to CRSs that can be used forward-facing, and from CRSs that can be used forward-facing to booster seats. The agency estimates potentially 0.7 to 2.3 lives will be saved and 1.0 to 3.5 moderate-to-critical severity injuries prevented annually by raising the manufacturer-recommended minimum child weight for the use of CRSs with internal harness that can be used forward-facing from 9 kg (20 lb) to 12 kg (26.5 lb). NHTSA also estimates potentially 1.2 to 4 lives will be saved and 1.6 to 5.2 moderate-to-critical injuries prevented by raising the manufacturer-recommended minimum child weight for use of booster seats from 13.6 kg (30 lb) to 18.2 kg (40 lb).

The changes to the labeling requirements will have minimal or no cost impacts. Manufacturers may provide the recommended child weight and height ranges for the use of CRSs in a specific installation mode on existing voluntary labels by simply changing the minimum child weight limit values. Since this final rule does not require additional information on the label, the size of the label will not need to be increased.

There will also be no decrease in sales of forward-facing CRSs with internal harnesses or of booster seats because of this rule's raising the minimum child weight limit values for forward-facing CRSs with internal harnesses and booster seats. Most forward-facing CRSs with internal harnesses cover a wide child weight range, so the labeling changes will only affect how consumers use the products and not the sale of them. For example, consumers will still purchase forward-facing CRS with internal harnesses but will just wait to use them until the child is at least one year old. They will still purchase convertible¹⁶ CRSs but will delay turning the child

¹⁶ A convertible CRS is a type of CRS with an internal harness to secure the child that can be used rear-facing and forward-facing.

forward-facing until the child is at least one year old. Consumers will still purchase booster seats but will use them when the child reaches 18.2 kg (40 lb) rather than 13.6 kg (30 lb).

Dummies (also called Anthropomorphic Test Devices (ATDs))

The updates to how NHTSA will use dummies in the compliance tests better accords with current CRS designs, best practices, and consumer use for transporting children compared to the current requirements in FMVSS No. 213. NHTSA cannot quantify the possible safety benefits at this time.

While manufacturers are required to certify their products meet the requirements of FMVSS No. 213 when tested in accordance with the standard and exercise due care in doing so, they are not specifically required to test their CRSs the way NHTSA tests child restraints in a compliance test. Assuming manufacturers choose to conduct the tests specified in FMVSS No. 213 to make their certifications of compliance, NHTSA estimates there will be no cost increases associated with the amendments.

Some of the changes lessen testing burdens by reducing the extent of testing with dummies. For example, the rule specifies that CRSs for children weighing 10 kg to 13.6 kg (22 to 30 lb) will no longer be required to certify the seats meet the requirement with the HIII-3YO dummy. NHTSA estimates a reduction in testing cost of \$717,600 for the current number of infant carrier models in the market. Child seats for children weighing 13.6-18.2 kg (30-40 lb) will no longer be required to be certified with the CRABI-12MO. The final rule also provides that CRSs used in the forward-facing mode will no longer be required to be certified using the CRABI-12MO dummy. NHTSA estimates a reduction in testing cost of \$2,373,600 for the forward-facing CRSs that will no longer be tested with the CRABI-12MO. The positioning procedure for the legs of the HIII-3YO dummy in CRSs used rear-facing is unlikely to have cost implications because the procedure is similar, if not identical, to that currently used by many manufacturers.

NHTSA believes there are only minimal costs associated with NHTSA's testing CRSs with the HIII-6YO dummy instead of the H2-6YO dummy. This is because there are likely to be little or no design changes to CRSs since nearly all the CRSs tested with the HIII-6YO in the updated standard seat assembly complied with the applicable FMVSS No. 213 requirements.¹⁷ Some commenters (Graco, JPMA, Dorel and Evenflo) opposed the proposal as they believe chin-to-chest contacts have not been resolved. NHTSA's testing showed that CRSs that currently comply with FMVSS No. 213 using the H2-6YO dummy also met all the performance requirements in the standard when tested using the HIII-6YO dummy on the updated standard seat assembly. Manufacturers are increasingly certifying at least some of their CRS models for older children using the HIII-6YO dummy rather than the H2-6YO and so for these manufacturers with these CRSs, the amendment will have no effect.

School Bus Child Restraint Systems

The amendments to FMVSS No. 213 include allowing new types of CRSs manufactured for exclusive use on school bus seats. There may be benefits associated with the manufacture and sale of CRSs for preschool and children with special needs, but NHTSA cannot quantify these benefits at this time.

II. Safety Need and NHTSA Strategies

a. 2020 Fatalities

Of the 38,825 traffic fatalities in 2020 in the United States, 755 were of child passenger vehicle occupants ages 0- 14 years old. Of these 755 fatalities, restraint use was known for 680 of the children. Two hundred eighty-six (286) (42%) were unrestrained, 176 (26%) were children restrained in a child restraint system, 209 (31%) were children restrained with a seat belt, and 9 (1%) were children restrained with an unknown type of restraint.

¹⁷ As discussed in the NPRM, of 21 tests with the HIII-6YO on the new seat assembly, all passed the performance metrics, except for one that failed head excursion limits.

There were 53 infants (under 1 year old) killed, with restraint use known for 48 of them. Of these 48 fatalities, 13 (27%) were unrestrained.

There were 128 children 1 to 3 years old killed, with restraint use known for 118. Of these 118 fatalities, 39 (33%) were unrestrained.

There were 207 children 4 to 7 years old killed; restraint use was known for 186. Of these 186 fatalities, 80 (43%) were unrestrained.¹⁸

b. NHTSA Strategies

NHTSA reduces child traffic injuries and fatalities through programs implemented in many program areas.

1. Increase CRS Use

NHTSA is actively involved in increasing CRS use. We conduct national campaigns to educate the public about the importance of restraining children with CRSs and work with stakeholders to get these messages out. These efforts include developing and distributing training videos, producing public safety announcements and various campaigns directed to caregivers of children (in English and Spanish), leveraging all communication resources (such as social media and the NHTSA website) to provide information to parents and other caregivers.

We teach caregivers about the kinds of restraints that are best suited to protect child occupants of various ages.¹⁹ NHTSA recommends that from birth to 12 months, children ride in a rear-facing car seat, and from 1 to 3 years they should be rear-facing as long as possible and then move to a harnessed and tethered forward-facing seat when they outgrow the rear-facing seat. From ages 4 to 7, children should ride in the harnessed and tethered forward-facing car seat until they outgrow the seat, then ride in a booster seat. From ages 8 to 12, children should be in a booster seat until they are big enough to fit a vehicle seat belt properly.²⁰

¹⁸ Source: <https://crashstats.nhtsa.dot.gov/Api/Public/ViewPublication/813285>.

¹⁹ The agency uses the term “car seat” or “car safety seat” rather than “child restraint system” in messages to caregivers, as the former terms are more commonly known and understood by laypersons than the latter. Consistent with plain language principles, this preamble uses these layperson’s terms from time to time.

²⁰ <https://www.nhtsa.gov/equipment/car-seats-and-booster-seats#age-size-rec>.

NHTSA works with State and local authorities to support child restraint use laws. The Bipartisan Infrastructure Law continues the 23 U.S.C. Section 405(b) Occupant Protection grant program that incentivizes States to adopt and implement effective occupant protection programs to reduce highway deaths and injuries resulting from individuals riding unrestrained or improperly restrained in motor vehicles.

To qualify, all States must demonstrate an active network of child passenger safety inspection stations based on the State's problem identification. States must provide the total number of planned inspection stations and/or events in the State; and tell NHTSA how many of those events serve urban, rural, and at-risk populations. States must certify that inspection stations are staffed with at least one current Nationally Certified Child Passenger Safety Technician. Additionally, to qualify for an Occupant Protection incentive grant, States must provide plans and projects for recruiting, training, and maintaining a sufficient number of child passenger safety technicians based on the state's problem identification.

States with seat belt use rates below 90 percent must submit additional information to qualify, which may include demonstrating that the State has enacted and is enforcing a primary enforcement seat belt or child restraint statute and/or that the State has enacted and is enforcing occupant protection statutes with specified criteria such as requiring all occupants be secured in an age-appropriate child restraint.

Trends in Restraint Use²¹

As a general trend we see more children staying in each CRS type longer. Older/heavier children are restrained in CRS used rear-facing, forward-facing CRS and booster seats longer

²¹ Sources: NSUBS- National Survey for the Use of Booster Seats – Multiple years; Enriquez, J. (2021, May). The 2019 national survey of the use of booster seats (Report No. DOT HS 813 033), NHTSA 813033 (dot.gov); Li, H. R., & Pickrell, T. (2018, September). The 2017 National Survey of the Use of Booster Seats (Report No. DOT HS 812 617). Washington, DC: NHTSA 812617 (dot.gov); Li, H. R., Pickrell, T. M., & KC, S. (2016, September). The 2015 National Survey of the Use of Booster Seats (Report No. DOT HS 812 309). Washington, DC: NHTSA 812309 (dot.gov); Pickrell, T. M., & Choi, E-H. (2014, June). The 2013 national survey of the use of booster seats. (Report No. DOT HS 812 037). Washington, DC: NHTSA 812037 (dot.gov); Pickrell, T. M., & Ye, T. J. (2013, April). The 2011 National Survey of the Use of Booster Seats. (Report No. DOT HS 811 718). Washington, DC: NHTSA 811718 (dot.gov).

before transitioning to the next kind of CRS partly because of the increased availability of CRSs sold for larger children, CRS best practice recommendations such as those cited above from NHTSA, and State child restraint laws. The trends below are positive developments aligned with increased safety outcomes.

Looking at restraint type use by age from 2011 to 2019 we see the following trends:

Children <1 year old

- Increase of CRSs used rear-facing from 83% to 91.7%
- Decrease of forward-facing CRS use from 11% to 5.7% (decrease mostly because more children of this age group are remaining rear facing longer)

Children 1-3 years old

- Increase of CRSs used rear-facing from 7% to 17.4%
- Decrease of forward-facing with internal harness CRS use from 75% to 66.3% (decrease mostly because more children of this age group are remaining in rear-facing longer)
- Decrease of belt-positioning seat (BPS) use from 11% to 7.5% (decrease due to more children of this age group are remaining in forward-facing with internal harness CRSs longer)

Children 4-7 years old

- Increase of forward-facing CRS use from 18% to 32.5%
- Decrease of BPS use from 46% to 37% (decrease due to more children of this age group remaining in forward-facing with internal harness CRSs longer)
- Decrease of seat belt only use from 25% to 16% (decrease due to more children of this group remaining in BPSs or forward-facing with internal harness CRSs longer)

Looking at restraint type use by child weight from 2011 to 2019 we see the following trends:

Children 0-20 lb

- Increase of CRS used rear-facing from 89% to 92.4%

- Decrease of forward-facing with internal harness CRS use from 9% to 4.2% (decrease mostly because more children of this weight group are remaining rear facing longer)

Children 21 to 40 lb

- Increase of CRSs used rear-facing from 7% to 15.2%
- Decrease of forward-facing CRS use from 61% to 58% (decrease mostly because more children of this weight group are remaining rear facing longer)
- Decrease of belt-positioning seat (BPS) use from 20% to 9% (decrease due to more children of this weight range remaining in forward-facing with internal harness CRSs)
- Decrease of seat belt only use from 6% to 5%

Children 41- 60 lb

- Increase of forward-facing with internal harness CRS use from 11% to 23.5%
- Decrease of BPS use from 45% to 39% (decrease partially because more children of this weight group are remaining in forward-facing with internal harness CRSs longer)
- Decrease of seat belt only use from 34% to 25.1% (decrease partially due to more children of this weight range remaining in BPSs or forward-facing with internal harness CRSs longer)

While trends of CRS use for children 0-4 years old have remained constant, we have seen an increase in CRS use for older children. NSUBS data from 2009 and 2019, shows that there's been an increase in CRS use from 55 to 69.7 percent in children 4-7 years old and 6 to 14.9 percent in children 8-12 years old. Based on child's weight, there has been an increase of CRS use from 43 to 62.5 percent among children weighing 41-60 pounds and an increase from 7 to 15 percent among children weighing more than 60 pounds.

This final rule amends FMVSS No. 213 to reflect the above trends in CRS use and design. We have better aligned the certification requirements for CRSs with the size and weight of children typically restrained by the various CRS types in use today.

2. Increase Correct Use

NHTSA’s programs work to increase correct use of child restraints. We work to make CRSs easier to use through rulemaking and other means. FMVSS No. 213 has requirements to ensure caregivers can attach any child restraint system, other than a school bus child restraint system, to any vehicle seat using just a seat belt.²² The agency has also established Standard 225, “Child restraint anchorage systems,” to require vehicles to have a standardized and easy to use dedicated anchorage system in certain vehicle rear seating positions that caregivers can use with a simple one-handed motion to attach a CRS. FMVSS No. 213 requires CRSs to have permanently attached components that can attach to the dedicated system. NHTSA requires child restraint manufacturers to provide information directly to owners informing them of the proper use of child restraint systems. NHTSA rates CRSs on their ease of use in a consumer information program under NHTSA’s New Car Assessment Program (NCAP). The NCAP program not only assists caregivers when making purchasing decisions, but also incentivizes manufacturers to improve the ease of correctly using child seats. NHTSA conducts national campaigns to educate the public about the importance of buckling children into child restraint systems, supports efforts by State and local organizations that would like to establish CRS fitting stations,²³ and works with partners to train educators that can teach the public about using child restraints.

FMVSS No. 213 requires manufacturers to provide safety information labeled on each CRS instructing caregivers on the correct use of the restraint. This final rule amends the standard to enhance the labeling requirements. For example, we are improving the labeling requirements to require manufacturers to provide information on when to transition a child to each specific mode in which the car seat can be used (rear-facing, forward-facing, booster). We are requiring that caregivers must not be instructed to turn children forward-facing until reaching 26.5 lb, and

²² NHTSA also has requirements in Standard 208, “Occupant crash protection,” to require seat belts to meet lockability requirements so that they may be easily locked for use with CRSs.

²³ These are places within a community where caregivers can learn how to install and properly use child restraints. Some places provide a certified technician that provides hands on support, fitting the caregiver’s child seat into their vehicle. To find a CPS Technician go to <https://portalskcms.cyzap.net/dzapps/dbzap.bin/apps/assess/webmembers/secure/manage?webid=SKCMS&pToolCode=CERT-SEARCH&pAdd=Yes> (last accessed April 21, 2023)

that boosters cannot be recommended for children under 40 lb. But we are also permitting manufacturers more leeway in how they communicate with caregivers, so designers can find ways to provide use instructions that their customers will read, understand, and follow.

3. Strengthen FMVSS No. 213 and Address Safety Defects

NHTSA undertakes rulemaking to ensure child restraint systems are as protective as possible. We review FMVSS No. 213 regularly and frequently to see how the standard could be strengthened to protect against unreasonable safety risks.

Child restraint systems are highly effective in reducing the likelihood of death and injury to children in motor vehicle crashes. NHTSA estimates that, for children less than 1 year old, a child restraint can reduce the risk of fatality by 71 percent when used in a passenger car and by 58 percent when used in a pickup truck, van, sport utility vehicle (SUV), or other multipurpose passenger vehicle (these non-passenger car vehicles together are known as light truck and van vehicles, or LTVs). Child restraint effectiveness for children between the ages of 1 and 4 years old is a very high 54 percent in passenger cars and 59 percent in LTVs.²⁴

FMVSS No. 213 specifies performance requirements that must be met in a dynamic frontal sled test involving a 48 kilometer per hour (km/h) (30 mile per hour (mph)) velocity change, which is representative of a severe crash. Each child restraint system is tested with a dummy while attached to a standardized seat assembly representative of a passenger vehicle seat (standard seat assembly).²⁵ FMVSS No. 213 has many safety benefits, a few of which are enumerated here. FMVSS No. 213 requires child restraint systems to limit the amount of inertial load that can be exerted on the head and chest of the dummy during the dynamic test. The standard requires child restraint systems to meet head excursion²⁶ limits to reduce the possibility

²⁴ Traffic Safety Facts – Children 2012 Data (April 2016).

<https://crashstats.nhtsa.dot.gov/Api/Public/Publication/812491>. Last accessed on January 3, 2023.

²⁵ FMVSS No. 213 specifies the use of test dummies representing a newborn, a 12-month-old, 3- and 6-year-old, weighted 6-year-old, and 10-year-old child. The dummies other than the newborn are equipped with instrumentation measuring crash forces, but NHTSA restricts some measurements from the weighted 6-year-old and 10-year-old dummies due to technical limits of the dummies.

²⁶ Head excursion refers to the distance the dummy's head translates forward in FMVSS No. 213's simulated frontal crash test.

of head injury from contact with vehicle interior surfaces and ejection. Child restraint systems must also maintain system integrity (e.g., not fracture or separate in such a way as to harm a child) and have no contactable surface that can harm a child in a crash. The standard ensures belt webbing can safely restrain the child, and that buckles can be swiftly unlatched after a crash by an adult - but cannot be easily unbuckled by an unsupervised child. Child restraint systems other than booster seats and harnesses²⁷ must meet performance requirements when attached to the standard seat assembly with the vehicle's seat belt, and, in a separate assessment, with only the lower anchorages of a child restraint anchorage system.²⁸ The CRSs must meet more stringent head excursion requirements in another test where a top tether, if provided, may be attached. Belt-positioning (booster) seats are tested on the standard seat assembly using a Type 2 (lap and shoulder) belt.

NHTSA continues to work to improve FMVSS No. 213. In June 2022, NHTSA added side impact requirements to the standard.²⁹ The agency's work on side impact requirements involved developing a dynamic sled test, a new child test dummy, and child injury criteria.³⁰ In January 2015, NHTSA proposed to amend FMVSS No. 225 to improve the ease of use of the lower anchorages of child restraint anchorage systems and of the tether anchorage.³¹ NHTSA is continuing its work on the Standard 225 rulemaking and will issue a final decision at a later date.

As part of the agency's work on FMVSS No. 213, this final rule will modernize the standard, with emphasis on the standard seat assembly. We believe, however, that the change to

²⁷ These types of child restraint systems are defined in S4 of FMVSS No. 213.

²⁸ Commonly called "LATCH," which refers to Lower Anchors and Tethers for Children, a term industry developed to refer to the child restraint anchorage system required by FMVSS No. 225 for motor vehicles (49 CFR 571.225, "Child restraint anchorage systems"). A child restraint anchorage system consists of two lower anchorages, and one upper tether anchorage. Each lower anchorage includes a rigid round rod, or "bar," onto which a hook, a jaw-like buckle or other connector can be snapped. The bars are located at the intersection of the vehicle seat cushion and seat back. The upper tether anchorage is a ring-like object to which the upper tether of a child restraint system can be attached. FMVSS No. 213 requires CRSs to be equipped with attachments that enable the CRS to attach to the vehicle's child restraint anchorage system.

²⁹ Final rule, 87 FR 39234, June 30, 2022, established FMVSS No. 213a; Child restraint systems -side impact protection. The compliance date for the requirements is June 30, 2025, with NHTSA permitting optional early compliance with the requirements.

³⁰ The final rule fulfilled a MAP-21 mandate in § 31501(a) that NHTSA issue a final rule to improve the protection of children seated in child restraint systems during side impacts.

³¹ Ease-of-use NPRM, 80 FR 3744; January 23, 2015. Initiation of the rulemaking was part of a 2011 NHTSA priority plan and is called for by MAP-21 (§ 31502(a)).

the updated standard seat assembly will not significantly affect the performance of CRSs in meeting FMVSS No. 213. As discussed in the NPRM preceding this final rule,³² NHTSA tested a wide variety of CRS designs in the market using the updated standard seat assembly. The CRSs had been certified by their manufacturers as meeting FMVSS No. 213's performance criteria using the current standard seat assembly in the standard (which is representative of designs of older vehicle seats). In the tests on the updated standard seat assembly, most CRSs also met the standard's performance requirements.³³

In 1992, NHTSA established a CRS owner registration program in FMVSS No. 213³⁴ (S5.8) to increase the "completion rate" of recalled restraints, i.e., the percentage of recalled units sold to consumers for which the consumer contacts the manufacturer for free remedy of the defect or noncompliance.³⁵ With this program, owners can be directly notified of safety recalls. This final rule improves the program to increase the likelihood that owners will be motivated to register with manufacturers to learn directly whether their CRS was recalled.

III. Statutory Authority

This final rule is issued under the Safety Act (49 U.S.C. 30101 *et seq.*) and MAP-21.

a. National Traffic and Motor Vehicle Safety Act (Safety Act)

Under the Safety Act, the Secretary of Transportation³⁶ is responsible for prescribing motor vehicle safety standards that are practicable, meet the need for motor vehicle safety, and are stated in objective terms.³⁷ "Motor vehicle safety" is defined in the Safety Act as "the performance of a motor vehicle or motor vehicle equipment in a way that protects the public against unreasonable risk of accidents occurring because of the design, construction, or

³² NPRM, *supra*, 85 FR at 69389, col. 3.

³³ During NHTSA's testing with the updated standard seat assembly, there were four CRSs models that failed head excursion limits: Britax Marathon and Britax Frontier reported in this final rule's Appendix A, as well as the Evenflo Titan Elite and Diono Radian R120 reported in the NPRM.

³⁴ 57 FR 41428.

³⁵ NHTSA also issued the rule to assist the agency in determining whether manufacturers met their recall notification responsibilities under the Safety Act, and to motivate owners to register CRSs for recall notification purposes.

³⁶ The responsibility for promulgation of Federal motor vehicle safety standards is delegated to NHTSA. 49 CFR 1.95.

³⁷ 49 U.S.C. § 30111(a).

performance of a motor vehicle, and against unreasonable risk of death or injury in an accident, and includes nonoperational safety of a motor vehicle.”³⁸ “Motor vehicle safety standard” means a minimum performance standard for motor vehicles or motor vehicle equipment.³⁹ When prescribing such standards, the Secretary must consider all relevant, available motor vehicle safety information, and consider whether a standard is reasonable, practicable, and appropriate for the types of motor vehicles or motor vehicle equipment for which it is prescribed.⁴⁰ The Secretary must also consider the extent to which the standard will further the statutory purpose of reducing traffic crashes and associated deaths and injuries.⁴¹

b. MAP-21

MAP-21 incorporates Subtitle E, “Child Safety Standards.” Section 31501(b)(1) of Subtitle E requires that not later than 2 years after the date of enactment of the Act, the Secretary⁴² shall commence a rulemaking proceeding to amend the standard seat assembly specifications under Federal Motor Vehicle Safety Standard Number 213 to better simulate a single representative motor vehicle rear seat. Section 31501(b)(2) states that not later than 4 years after the date of the enactment of the Act, the Secretary shall issue a final rule pursuant to paragraph (1).

c. NHTSA’s Views

NHTSA is issuing this final rule under Safety Act authority and MAP-21. Section 31501(b)(2) of MAP-21 directs NHTSA to issue a final rule amending the standard seat assembly of FMVSS No. 213. NHTSA believes that, in requiring a final rule amending “Federal Motor Vehicle Safety Standard Number 213,” Congress’s intent is that the rulemaking on the standard seat assembly will accord with the requirements and considerations for FMVSSs under the Safety Act.

³⁸ 49 U.S.C. § 30102(a)(8).

³⁹ 49 U.S.C. § 30102(a)(9).

⁴⁰ 49 U.S.C. § 30111(b).

⁴¹ *Id.*

⁴² Authority delegated to NHTSA. 49 CFR 1.95(p)(2).

IV. Guiding Principles

We undertake our rulemakings on FMVSS No. 213 with the following principles and considerations in mind. We weigh these factors in addition to the considerations and requirements for FMVSS specified by the Safety Act, statutory mandates, Executive Order (E.O.) 12866,⁴³ and other requirements for agency rulemaking. NHTSA articulated these guiding principles in the NPRM.⁴⁴ We have announced these principles in other rulemakings involving the standard.⁴⁵

Child restraint misuse is high, but even with misuse, child restraints are highly effective in reducing the likelihood of death and/or serious injury in motor vehicle crashes. As discussed above, based on real-world data, child restraint effectiveness for children between the ages 1 to 4 years old is 54 percent in passenger cars and 59 percent in light trucks. The failure to use occupant restraints is a significant factor in most fatalities resulting from motor vehicle crashes.

In making regulatory decisions on possible enhancements to Federal standards, the agency must bear in mind the consumer acceptance of cost increases to an already highly effective item of safety equipment and whether an enhancement that could raise the price of the restraints could potentially have an adverse effect on the sales of this product. The net effect on safety could be negative if the effect of sales losses on usage rates exceeds the benefit of the improved performance of the restraints. To maximize the total safety benefits of extending and upgrading its restraint requirements, the agency balances those improvements against the real-world impacts on the price of restraints. NHTSA also weighs the effects of improved performance on the ease of correctly using child restraints. We consider whether an amendment may cause child restraints to become overly complex or frustrating for caregivers and the risk that a requirement could unintentionally exacerbate misuse and nonuse of child restraints.

V. Overview of the NPRM and Comments Received

⁴³ E.O. 12866, “Regulatory Planning and Review,” September 30, 1993, as amended by E.O. 14094.

⁴⁴ 85 FR at 69404, col. 2. (Discussion of NHTSA’s decision not to raise the crash pulse in FMVSS No. 213’s compliance test.)

⁴⁵ See, e.g., final rule, FMVSS No. 213a side impact requirements, 87 FR at 39243, col. 1, *supra*.

a. Summary of the NPRM

NHTSA published the NPRM for this final rule on November 2, 2020 (85 FR 69388). We extended the comment period to April 5, 2021 (86 FR 47; January 4, 2021) in response to petitions under 49 CFR 553.19 from the Juvenile Products Manufacturers Association (JPMA) and the Children’s Hospital of Philadelphia (CHOP). (This summary is brief because it mirrors the description of the final rule provided in the Executive Summary, *supra*.)

1. NHTSA proposed to update the standard seat assembly used in the frontal dynamic test.⁴⁶ NHTSA proposed to test CRSs with the Type 2 belt system and to phase out use of the Type 1 belt. NHTSA did not include a vehicle floor and explained its reasons for denying a petition for rulemaking that had requested a floor. We discussed in the NPRM several test programs we conducted to assess the performance of child restraints on the proposed standard seat assembly.⁴⁷ In one of the final test series in the NPRM phase, NHTSA performed 40 tests using 24 CRS models across 10 brands available in the marketplace using the proposed standard seat assembly (V2).⁴⁸

The results showed that changing to the updated standard seat assembly had almost no effect on the ability of the CRS to pass the frontal dynamic crash requirements of FMVSS No. 213. Results showed the following:

Infant carriers and convertibles positioned rear-facing and tested with the CRABI-12MO or the HIII-3YO dummies: We tested six (6) CRS models with the CRABI-12MO dummy and tested 4 with the HIII-3YO dummy. All the child restraints met all the frontal dynamic crash requirements evaluated during this set of tests.

⁴⁶ The NPRM included a proposal to incorporate by reference a drawing package containing detailed drawings of the proposed standard seat assembly. A description of the materials proposed for incorporation by reference can be found at 85 FR at 69443, col. 1.

⁴⁷ Section VII of the NPRM preamble, 85 FR 69409-69424.

⁴⁸ During the development of the NPRM the agency worked with two design levels of the preliminary standard seat assembly and the term “V2” is referring to one of them. The initial standard seat assembly design (V1) used in some sled tests during the development of the design only differed from the proposed standard seat assembly (V2) in minor ways. The initial standard seat assembly used in these sled tests had a shorter seat back height and slightly different seat belt and child restraint anchorage locations. NHTSA performed tests on the proposed standard seat assembly (V2) of some of the CRSs that were tested on V1 standard seat assembly; results showed no significant difference in CRS performance on the two standard seat assemblies.

Forward-facing CRSs tested with the HIII-3YO dummy: We tested one (1) CRS model with tether attached and two (2) CRS models without tether attached. All child restraints met all the frontal dynamic crash requirements evaluated during this set of tests.

Forward-facing CRSs tested with the HIII-6YO dummy: Four (4) CRSs tested with the tether attached met all the frontal dynamic crash requirements evaluated during this set of tests. Four (4) CRS models were tested without the tether attached. All met all the frontal dynamic crash requirements evaluated during this set of tests.

Forward-facing CRSs tested with the Hybrid III 10-year-old (HIII-10YO) dummy: One (1) CRS model was tested with the tether attached and 2 CRS models were tested without the use of the tether. The CRS tested with the tether attached met all frontal dynamic crash requirements evaluated during this set of tests. The CRSs tested without the tether met all frontal dynamic crash requirements evaluated during this set of tests, except for one that exceeded the head excursion limit.

Booster seats with the HIII-6YO dummy: We tested six (6) booster seat models and all met all frontal dynamic crash requirements evaluated during this set of tests.

Booster seats with the HIII-10YO dummy: We tested three (3) booster seat models and all met all frontal dynamic crash requirements evaluated during this set of tests.

2. The NPRM proposed to reduce the restrictions on the content and format of the owner registration form manufacturers must provide with new CRSs for purposes of direct recall notifications (S5.8).

3. NHTSA proposed to amend labeling requirements so that manufacturers have more flexibility in informing and instructing caregivers about correctly using child restraints (S5.5), but with caveats, e.g., forward-facing CRSs must not be recommended for children weighing less than 12 kg (26.5 lb) and booster seats must not be recommended for children weighing less than 18.4 kg (40 lb).

4. NHTSA proposed to streamline the agency's use of test dummies in compliance tests (S7) to make the dummies more representative of the children for whom the CRS is recommended. The NPRM proposed to phase out a provision that permitted, at the manufacturer's choice, an option of certifying CRSs using the H2-6YO dummy instead of a more advanced Hybrid III dummy.

5. The NPRM proposed miscellaneous amendments. These included permitting more types of CRSs designed for exclusive use on school buses than are currently permitted, updating a reference to an SAE Recommended Practice J211, and several housekeeping amendments to delete or clarify various provisions in the standard.

6. The NPRM also requested comment on a separate document discussing several developments in child passenger safety, including research studies that raise safety concerns associated with inflatable belt-positioning seats and a shield-only type of child restraint emerging in markets overseas.⁴⁹ The document also discusses our observations that children are outgrowing the height limits of some rear-facing infant carriers long before they outgrow the weight limits. NHTSA asked whether height and weight limits should better match.

b. Summary of the Comments

The NPRM received over 29 comments or other submissions to the docket. Commenters included child restraint manufacturers (JPMA, Dorel Juvenile Group, Graco Children's Products, Britax Child Safety, Inc., Cybex, Evenflo, Safeguard/IMMI, BubbleBum); consumer advocates (the American Academy of Pediatrics, Advocates for Highway and Auto Safety, Safe Ride News (SRN), Safety Belt Safe (SBS), the National Safety Council, Consumers Reports); research bodies and testing organizations (Insurance Institute for Highway Safety (IIHS), CHOP, University of Michigan Transportation Research Institute (UMTRI), MGA Research Corporation); vehicle manufacturers, suppliers, and associations (Volvo, the Automotive Safety

⁴⁹ Child Passenger Safety Issues Arising from Research Findings. January 13, 2020. Docket No. NHTSA-2020-0093-0013 at <https://www.regulations.gov/>

Council (ASC), the National Automobile Dealers Association (NADA), Transport Research Laboratory); and entities directly involved with pupil transportation (the National Association for Pupil Transportation (NAPT), Salem-Keizer Public Schools). Additionally, the People's Republic of China submitted a comment, as did several members of the general public.

Overview of the Comments

There was wide support overall for the NPRM. All commenters on the issue supported updating the standard seat assembly, but some expressed concern about specifics of the proposed standard seat assembly. Graco raised concerns about the repeatability and reproducibility (R&R) of test results using the proposed standard seat assembly and JPMA and some of its member companies had questions about the cushion foam. Some commenters addressed technicalities of the proposed standard seat assembly and/or test conditions and procedures (e.g., limits on belt webbing elongation, placement of cameras, methods for measuring the firmness of seat foam). Some suggested ways the proposed standard seat assembly and test could be revised to reduce potential sources of variability. Two wanted the Type 1 belt retained on the seat assembly, as they believed the Type 1 belt test should remain in FMVSS No. 213 to ensure the availability of child seats to persons owning older vehicles that only have Type 1 belts in rear seating positions.

There was strong support overall for the proposed changes to the owner registration form and the labeling requirements, but several consumer advocates cautioned that too much flexibility in form and content may reduce the familiarity, and utility, of the form and labels. There was unanimous support for the provision that booster seats should not be recommended for children under 40 lb, but several were concerned about shortcomings with a study we had cited. Commenters overall supported the changes to the agency's use of test dummies in compliance tests, but JPMA and some individual manufacturers opposed phasing out the optional use of the H2-6YO dummy.

Many commenters provided input on issues that were outside of the scope of the rulemaking. Many commenters suggested changes to the proposed standard seat assembly

regarding features they believed should be included on the standard seat assembly, but which were not proposed, such as a floor, or a front seat positioned forward of the standard seat assembly.⁵⁰ Consumer Reports suggested use of a weighted 12-month-old test dummy. JPMA reiterated a concern it has about Standard 302's flammability resistance requirement incorporated into FMVSS No. 213 (S5.7), and the People's Republic of China commented that it believes the flammability resistance standard for child restraint systems is too strict and should be harmonized with international standards to avoid a large use of flame retardants. Several comments responded to the January 13, 2020, document discussing NHTSA's concerns about data related to certain child restraint system designs.

All issues raised in relevant comments are discussed below in this preamble. Comments outside the scope of the rulemaking generally will not be further addressed in this document but are considered by NHTSA as suggestions for future revisions to FMVSS No. 213.

Some commenters brought up a few test procedures or regulatory provisions that they believe would make the criteria for determining compliance with FMVSS No. 213 clearer, or test results more repeatable and reproducible. NHTSA agrees generally the suggestions have merit but does not believe they should be adopted in this final rule. The Administrative Procedure Act requires that interested persons be given notice of proposed rulemaking and an opportunity to comment thereon prior to an agency's adopting changed requirements as a final rule (5 U.S.C. 553). Thus, to provide interested persons an opportunity to comment on possible changes to the test procedures, we are preparing an NPRM to tighten up some aspects of the adopted standards. The upcoming NPRM would include: a conforming amendment to FMVSS No. 213a (side impact protection) that the CRABI-12MO would not be used forward-facing to test CRSs that are recommended not for use forward-facing with children weighing less than 12 kg (26.5 lb); a procedure to ensure tightness of a CRS to consistent levels when there is insufficient free webbing on which to use a three-prong tension gauge; and a dummy rear head drop test to

⁵⁰ The front seat would be used to assess if child restraints prevent dummy head strikes against the seat back.

calibrate the responses of the HIII-3YO dummy. The upcoming NPRM would have a comment period that would provide any interested persons with the chance to comment on the changes while allowing the agency to move promptly to incorporate the changes into FMVSS No. 213 and No. 213b.

VI. Updating the Representative Standard Seat Assembly

This final rule amends the standard seat assembly specified by FMVSS No. 213 to better simulate “a single representative motor vehicle rear seat,” as directed by § 31501(b) of MAP-21.⁵¹ The updated standard seat assembly has one seating position. The updated standard seat assembly’s features are aligned with (and, in many respects, identical to) the seat assembly used to test child restraint systems for compliance with FMVSS No. 213a, “Child Restraint Systems--Side Impact Protection.” Comments to this topic supported the alignment of the sleds in both standards.⁵² This final rule includes specifications for the geometry of the seat (e.g., seat back angle, seat pan angle and length, seat back height), seat cushion characteristics (e.g., stiffness of the cushions and thickness of the foams), and the means (seat belt systems and child restraint anchorage system) for attaching a CRS to the seat. The report, “Development of a Representative Seat Assembly for FMVSS No. 213,” September 2016, which was docketed with the NPRM, explained how we developed the specifications for the seat.⁵³

The agency used data from a 2012 research program (Vehicle Rear Seat Study) to assess the representativeness of the current FMVSS No. 213 standard seat assembly and to develop an

⁵¹ This final rule incorporates by reference a final drawing package with the detailed drawings of this final rule’s standard seat assembly. The drawing package is discussed in detail in this preamble and can be found in the docket for this final rule and elsewhere. See the section titled Incorporation by Reference in the “Regulatory Notices and Analyses” section of this preamble, *infra*.

⁵² The 2020 NPRM preceding this final rule sought comment on the issue of consistency between the seat assemblies used in the side and frontal impact tests. 85 FR 69394, col. 2. The commenters responding to this issue strongly supported aligning the two seat assemblies as reasonably possible. NHTSA also discussed this issue in the 2022 final rule establishing the MAP-21 CRS side impact requirements. We explained in that side impact rule that we adopted a seat assembly that is aligned as possible with the FMVSS No. 213 frontal impact test assembly. 85 FR 39261-39262; June 30, 2022.

⁵³ <https://www.regulations.gov/document/NHTSA-2020-0093-0005>. 85 FR at 69397.

updated standard seat assembly.⁵⁴ The Vehicle Rear Seat Study surveyed vehicles in the U.S. vehicle fleet to compile data on the rear seat environment. The study measured 43 individual rear seating positions in 24 model year (MY) 2010 vehicles. Measurements were made of features that included seat back angle and height, seat pan width, stiffness of the seat cushion, location of seat belts and locations of child restraint anchorage systems.⁵⁵

The Vehicle Rear Seat Study measured the vehicles' seat geometry and anchorage locations using a Seat Geometry Measuring Fixture (SGMF). The SGMF consisted of two wooden blocks (600 mm x 88 mm x 38 mm) and a 76 mm (3 inches) hinge (see Figure 1 below). To make the rear seat geometry measurements, the SGMF was positioned on the centerline of each rear seating position. Point A (see Figure 1), which corresponds to the hinge location of the SGMF, was the reference point for all measurements.



Figure 1. SGMF sketch (left), SGMF positioned in a vehicle rear (center) seating position.

a. Seat Geometry

⁵⁴ Aram, M.L., Rockwell, T., "Vehicle Rear Seat Study," Technical Report, July 2012. Report available in the docket for the 2020 NPRM preceding this final rule (Docket No. NHTSA-2020-0093).

⁵⁵ 68 FR 37620, June 24, 2003. The 2020 NPRM has more background on NHTSA's work developing this final rule's updates to the standard seat assembly (see Section III, 85 FR at 69393).

1. Seat Back Angle

This final rule specifies a seat back angle of 20 degrees for the updated standard seat assembly, as proposed in the NPRM. The Vehicle Rear Seat Study found that the average seat back angle of the surveyed vehicles was 20 degrees from vertical, with a standard deviation of 4 degrees.⁵⁶ The seat back angle ranged from a minimum of 9 degrees to a maximum of 28 degrees from vertical. The value is representative of the seat back angles found in the vehicle fleet (within one standard deviation of the average values in the current fleet). No commenter opposed adopting this seat back angle. The seat back angle will simplify the change to a updated standard seat assembly because it will be the same as the angle of the current FMVSS No. 213 test seat assembly and that of the seat for the side impact test.

2. Seat Pan Angle

This final rule adopts the proposed seat pan angle of 15 degrees. No commenter opposed adopting this seat pan angle. The measurement is representative of seat pan angles found in the vehicle fleet (within one standard deviation of the average values in the current fleet).⁵⁷ The seat pan angle is the same as the angle of the current FMVSS No. 213 standard seat assembly and that of the side impact standard seat assembly.

3. Seat Pan Length

This final rule adopts the proposed seat pan length of 412 mm (16.2 inches). No commenter opposed adopting this seat pan length dimension. The measurement is representative of seat pan length found in the vehicle fleet (within one standard deviation of the average values in the current fleet).⁵⁸

4. Seat Back Height

⁵⁶ The current seat back angle of the FMVSS No. 213 standard seat assembly is 20 degrees.

⁵⁷ The Vehicle Rear Seat Study found that the average seat pan angle was 13 degrees from the horizontal, with a standard deviation of 4 degrees.

⁵⁸ The Vehicle Rear Seat Study found that the average seat pan length was 16.3 inch (416 mm), with a standard deviation of 38 mm (1.5 inches).

This final rule adopts the proposed seat back height of 573 mm (22.5 inches) for the updated standard seat assembly. No commenter opposed adopting this dimension. The Vehicle Rear Seat Study showed that the average height of the seat back was 688 mm (27 inches) with a standard deviation of 76 mm (3 inches) when the head restraint was included and 578 mm (22.7 inches) with a standard deviation of 60 mm (2.3 inches) when the head restraint was not included in the measurement.⁵⁹ The final rule's dimension of 573 mm (22.5 in) is within one standard deviation of the average seat back height when the head restraint is not included. The updated standard's seat assembly does not include a head restraint.⁶⁰

b. Rear Seat Cushion Characteristics

The standard seat assembly's seat cushion is made up of a seat cover and seat foam. In drafting the NPRM, the agency developed a new seat foam that was representative of the current U.S. vehicle fleet after finding that foams used in test programs overseas were not representative of U.S. vehicles. We sought to propose a foam that was representative of foams used in vehicle seats, as measured in terms of thickness, stiffness, and density. We also sought a foam that would not "bottom out" (fully compress) on to the rigid backing during the demanding conditions of a compliance test. We proposed to specify properties of a foam manufactured by The Woodbridge Group (Woodbridge),⁶¹ which we referred to as the "NHTSA-Woodbridge seat cushion." The NPRM described the proposed foam by its thickness, indentation force-deflection (IFD) test results, compression-force deflection (CFD) test results, and density.^{62, 63}

1. Thickness--Seat Back Cushion

⁵⁹ The current FMVSS No. 213 standard seat assembly has a seat back height of 20.35 inch (517 mm) and it does not have a head restraint.

⁶⁰ The final drawings for the updated standard seat assembly include for optional use an ATD Head Protection Device to protect the head of the dummy from damage when tested in backless booster seats. This is discussed in more detail later in the preamble.

⁶¹ The Woodbridge Group is a supplier of automotive seat foam, <http://www.woodbridgegroup.com>.

⁶² The IFD test measures the force required for 25 percent, 50 percent, and 65 percent deflection of the entire product sample. The CFD test measures the force required to compress a sample of the foam (50 mm (1.96 inch) by 50 mm and 25 mm (0.98 inch) thickness) by 50 percent.

⁶³ 85 FR at 69397.

For the seat back cushion, NHTSA proposed to use the NHTSA-Woodbridge seat cushion foam with a 50.8 mm (2 inch) thickness. A 50.8 mm (2 inch) thickness is representative of seat back cushions in the fleet. The Vehicle Rear Seat Study showed that the overall seat back cushion thickness for outboard and center seating positions was 76 mm (3 inches) with a standard deviation of 29 mm (1.14 inches), measured at the centerline of the seating position. The seat back cushion thickness of 50.8 mm (2 inches) is within 1 standard deviation of the average seat back cushion thickness in the vehicle fleet.

Another consideration we had for the proposal was that, while NHTSA does not believe that the seat back cushion significantly affects a CRS's dynamic performance in the frontal sled test, a seat back cushion on the thicker side could be a potential source of variability when testing CRSs with top tethers. When the tether is tightened, the back cushion can be compressed to varying degrees. Data does not indicate that differences in compression necessarily affect CRS performance, but NHTSA explained that a 50.8 mm (2 inch) thick foam would reduce such differences and thus facilitate a more repeatable installation. The agency noted also that specifying a 50.8 mm (2 inch) thickness streamlines the FMVSS No. 213 compliance test. Foam manufacturers readily produce foams in 101.6 mm (4 inch) sections. A 101.6 mm (4 inch) thick foam slab can be easily cut into two 50.8 mm (2 inch) pieces to be used for the seat back.

No commenter opposed adopting the proposal on the seat back cushion thickness. This final rule adopts the proposal for the reasons in the NPRM.

2. Thickness –Seat Bottom Cushion

NHTSA proposed a thickness of 101.6 mm (4 inches) for the bottom seat cushion foam. A 101.6 mm (4 inch) thickness would be representative of the seat cushions in real world vehicles. The Vehicle Rear Seat Study found an average seat pan cushion thickness for both outboard and center seating positions of 90 mm (3.5 inches) with a standard deviation of 40 mm (1.5 inches), measured at the centerline of the seating position.⁶⁴ A 101.6 mm (4 inch) seat

⁶⁴ The current FMVSS No. 213 standard seat assembly seat pan cushion has a thickness of 152.4 mm (6 inch).

cushion foam thickness for the seat pan also has the advantage of simplifying procurement of the foam since foam standard specifications are typically provided by the manufacturer in 101.6 mm (4 inches) samples, as specified in test method B1 of ASTM D3574, “Standard Test Methods for Flexible Cellular Materials—Slab, Bonded, and Molded Urethane Foams.”

Comments Received

After the agency submitted the NPRM to the Federal Register in September 2020 and placed a copy on NHTSA’s website, JPMA contacted NHTSA via email on October 15, 2020 to ask about the foam.⁶⁵ JPMA focused on a technical report⁶⁶ describing the use of adhesives to produce a foam of the requisite size for the proposed seat cushion. JPMA stated it preferred not using adhesives and asked NHTSA about an approach where JPMA would invest in a mold to produce a foam with the desired dimensions without adhesive use. JPMA asked if one-piece foams would be acceptable and whether the foam should have skin or not. NHTSA responded by stating that the proposed specifications did not have provisions for or against gluing or about skins. NHTSA noted that the agency had used adhesives and that the skin of the foam did not affect the performance in our testing.⁶⁷

JPMA commented that they were planning to initiate a test project to evaluate the foam at different laboratories and that JPMA would share their results when ready. On December 15, 2021, JPMA met virtually with NHTSA to present its research findings.⁶⁸

In the meeting, JPMA urged NHTSA to reduce the tolerance provided for the thickness of the foam. JPMA said it observed that the specified foam thickness and density tolerances allow for inconsistent test results separately and more so if the thickness and density variation

⁶⁵ The ex parte communication was documented here: Docket No. NHTSA-2020-0093-0050, at <https://regulations.gov/>.

⁶⁶ Wietholter, K., Loudon, A., & Echemendia, C. (2016, September). Development of a representative seat assembly for FMVSS No. 213. Washington, DC: National Highway Traffic Safety Administration. Docket No. NHTSA-2020-0093-0005. (p. 18)

⁶⁷ The reference was to Wietholter, K., Loudon, A., Sullivan, L, “Evaluation of Seat Foams for the FMVSS No. 213 Test Bench,” June 2016, <https://www.regulations.gov/document?D=NHTSA-2013-0055-0013>.

⁶⁸ The ex parte communication was documented here: Docket No. NHTSA-2020-0093-0050 at <https://regulations.gov/>.

within the tolerance are combined.⁶⁹ JPMA stated that the inconsistencies in test results would be higher when the combined effect of the tolerances of foam thickness and density are considered. In its comments to the NPRM, Graco had also expressed concerns regarding the effect of foam thickness tolerance on results. Graco stated that the seat pan cushion is nominally 102 millimeters (mm) (4.00 inches) thick with a tolerance of ± 12.7 mm (± 0.50 inches); and the seat back cushion is nominally 51 mm (2.00 inches) thick with a tolerance of ± 6.4 mm (± 0.25 inches). Graco argued that the current foam pieces have a tolerance on their thicknesses of $\pm 1/8$ inches (± 3.2 mm). Graco recommended that the tolerance be reduced to the minimum amount feasible to better ensure repeatable and reproducible test results.

In JPMA's ex parte meeting with NHTSA on December 15, 2021, JPMA presented its research findings on the effect of foam thickness. JPMA procured seat foams with three thicknesses spanning the proposed tolerance range⁷⁰ and tested in four configurations. The four configurations included the CRABI-12MO, HIII-3YO, HIII-6YO, and HIII-10YO dummies in rear-facing, forward-facing and belt positioning CRSs. It presented pictures of pre-test positioning of the dummies in the CRS to show how the foam thicknesses affected the positioning of the dummies.

JPMA then presented data on how the foam thicknesses affected the injury measures in the different tests. Results were mixed as the foam thickness variability contribution ranged from 3.1 percent to 87.5 percent depending on the CRS/dummy configuration and injury measure. Overall, in tests with the CRABI-12MO dummy in a CRS used rear-facing (3.1 to 28.6 percent) and the HIII-6YO in a forward-facing CRS (9.2 to 24.7 percent), the foam thickness variation had the least effect on injury measures, while in tests with the HIII-3-year-old in a forward-facing CRS, the foam thickness variation had the most effect on injury measures (30 to 87.5 percent). JPMA concluded that the variation in foam thickness resulted in greater than 10 percent

⁶⁹ A tolerance limit is a measure used to ensure the uniformity of an item. Any item that falls outside of the specified tolerance limit is deemed outside of the specification.

⁷⁰ Thickness of three seat foam samples were 112.31mm, 102.01 mm and 93.19 mm.

variation in 15 out of the 17 dummy response measures. JPMA also suggested adding a flatness specification to reduce variation in foam surface profile.

Agency Response

NHTSA is reducing the seat foam cushion thickness tolerance from 4 ± 0.5 inches to 4 ± 0.25 inches. NHTSA reviewed JPMA's data presented at the virtual meeting. JPMA claimed that the results of testing with the wide range of thicknesses (3.5 in, 4 in and 4.5 in) resulted in foam thickness variability contribution from 3.1 percent to 87.5 percent depending on the CRS/dummy configuration and injury measure. JPMA presented data of its testing and calculated the coefficient of variation (CV) values when taking all tests of the same CRS tested at the different foam thicknesses ranging 3.5 to 4.5 inches. The approximate calculations showed CV values under 10 percent which is still within the variability expected of the testing. Therefore, even if the foam contributed to variability to some extent, the variability is still within a reasonable range. However, NHTSA believes it is feasible to procure foams with a smaller tolerance without any additional burden and agrees that 0.5-inch tolerance in a 4-inch foam might be unnecessarily wide. Therefore, this final rule specifies a 0.25-inch thickness tolerance for the seat foam bottom cushion.

With regard to a requested flatness specification, we understand this request as seeking a specification that will ensure the foam slab has to have the same "thickness" throughout the slab. We did not adopt a flatness specification as we have reduced the tolerance for the foam slab thickness. With the reduced tolerance, even if variations are present, they will be small and inconsequential.

3. Foam Stiffness

NHTSA proposed specifications for the stiffness of the bottom seat cushion after comparing the stiffness of rear seat cushions in the fleet to that of the seat cushions used in various test programs, including FMVSS No. 213. NHTSA first measured the quasi-static stiffness (force-deflection) of the seat cushions in rear seats of 13 passenger vehicles (Model

Years 2003-2008).⁷¹ Next, since CRSs are tested on the FMVSS No. 213 standard seat assembly in a dynamic sled test, NHTSA also evaluated the dynamic stiffness of the various seat cushions. NHTSA believed that the stiffness of the NHTSA-Woodbridge seat cushion satisfactorily represents the average seat cushion stiffness found in the vehicle fleet and did not bottom out in the severe impact tests we conducted (35 g at 56.3 kilometers per hour (km/h) or 35 mph using heavy test dummies restrained in heavy child restraints).⁷²

Comments Received

In its comments to the NPRM, Graco presented its assessment of the potential effects of Indention Force-Deflection (IFD)⁷³ values close to both ends of the tolerance zone. For one of Graco's seats (Seat H⁷⁴), the IFD was measured and recorded before each dynamic test. Graco's data showed that increasing the IFD strongly correlated to increased chest resultant accelerations.

Graco explained that IFD values can be affected by foam density and overall thickness and, potentially, by temperature and humidity conditions during storage. Graco recommended that, in addition to tightening the tolerance on the thickness, NHTSA should reduce the permitted tolerance range of new foam IFD and provide guidance on the acceptable ranges of temperature and humidity for proper foam storage. Graco noted that Appendix C⁷⁵ of NHTSA's Research Test Procedure describes the practice that was followed by NHTSA's Vehicle Research and Test Center (VRTC) in testing that NHTSA conducted in developing the NPRM, but that this information was not in the NPRM or addressed in the current NHTSA's Compliance Test Procedure (TP-213-10).

Agency Response

⁷¹ NPRM, 85 FR at 69395. Wietholter, K., Loudon, A., and Sullivan, L. "Evaluation of Seat Foams for the FMVSS No. 213 Test Bench," June 2016 available in the docket for the NPRM.

⁷² NPRM, 85 FR at 69398.

⁷³ Indentation Force Deflection (IFD) tests measure firmness of flexible polyurethane foam cushions. High IFD test results imply increased stiffness.

⁷⁴ For details of Graco's data see comments at Docket No. NHTSA-2020-0093-0035 attachment titled "Graco comment NHTSA 2020 0093 Att A."

⁷⁵ NHTSA's "Research Test Procedure" for the Proposed FMVSS No. 213 Frontal Impact Test can be found in Docket No. NHTSA-2020-0093-0016.

NHTSA would like to begin by explaining the difference between the agency’s “Research Test Procedure” and NHTSA’s Compliance Test Procedure. The “Research Test Procedure” is the procedure that NHTSA’s VRTC developed and used during the development of this rulemaking. This Research Test Procedure is generally aligned with NHTSA’s proposal for FMVSS No. 213 and has been used by NHTSA in various ways to inform the agency’s decision-making developing the proposal. This Research Test Procedure offers details for interested readers on how NHTSA conducted the tests (e.g., which camera placements were used, how excursions were measured, CRS targeting for dynamic measurements, foam storage and testing protocols, etc.). NHTSA’s “Compliance Test Procedures” describe procedures NHTSA uses for compliance testing and are administered by NHTSA’s Office of Vehicle Safety Compliance (OVSC) as guidance.⁷⁶ The Compliance Test Procedures are consistent with FMVSS No. 213 as set forth in the Code of Federal Regulations, and is used as a contractual document between OVSC and the test lab contractor to describe the procedures that the contractor is to use to conduct an OVSC compliance test identified in the Test Procedure. The procedure in the Compliance Test Procedure falls within the parameters described in the test procedure set forth in the corresponding Federal Motor Vehicle Safety Standard. NHTSA considers the lessons learned from the agency’s research when writing the Compliance Test Procedures, but the Compliance Test Procedures could differ from the research procedures to address agency needs and interests that arise during administration of NHTSA’s compliance test programs.

The Research Test Procedure NHTSA used for developing the updated FMVSS No. 213 sled, including the foam, was published along with the NPRM.⁷⁷ The Research Test Procedure (and accompanying test reports) shed light on NHTSA’s decision-making for the proposal, but do not serve as regulation. NHTSA is developing the Compliance Test Procedure and will

⁷⁶ The Compliance Test Procedures for all of the Federal Motor Vehicle Safety Standards can be found here: <https://www.nhtsa.gov/vehicle-manufacturers/test-procedures>.

⁷⁷ NHTSA Research Procedure for the Proposed FMVSS No. 213 Frontal Impact Test can be found in Docket No. NHTSA-2020-0093-0016

consider what was learned about IFD testing and foam storage during the research work when drafting the Compliance Test Procedure administered by OVSC.

This final rule adopts the proposed stiffness characteristics for the seat cushion for the reasons in the NPRM. The stiffness of the NHTSA-Woodbridge seat cushion is satisfactorily representative of the average seat cushion stiffness found in the vehicle fleet.

In response to Graco's suggestion to narrow the IFD specifications, we have not found a need to do so. While there may be some response changes to the chest acceleration (or other values) that depend on the IFD values, the changes Graco presented also showed good repeatability with a CV of 7 for chest accelerations on Seat H and under 10 percent CV for Graco's other tested seats. The variations in performance measures caused by the proposed range of IFD values were still within acceptable variability levels, and, therefore, will be adopted in this final rule.

JPMA asked why the tolerances of the IFD Procurement Specifications were different than the Certification Specifications.

In response, NHTSA believes the following background is helpful. The proposed drawings in the NPRM indicated Procurement and Certification specifications for the seat pan and seat back foams. The specifications serve different purposes. Procurement specifications are verified by the foam manufacturer or distributor when the foam is sold. Certification specifications are verified prior to sled testing by the laboratory performing the test. The procurement specification tests measure the density and the compression force deflection (CFD) of a foam and identify the foams that are suitable for FMVSS No. 213 testing. They are destructive tests (a specimen piece of the produced foam is cut off to perform the tests) and, therefore, cannot be repeated multiple times before dynamic sled testing for FMVSS No. 213. The indentation force deflection (IFD) tests are not destructive tests, and at procurement, the foam manufacturer or distributor can perform IFD tests to also identify the foam characteristics. Once the foam has been procured, the Certification specifications, which only indicate IFD

characteristics, can be used to certify and ensure that the foam has the required IFD characteristics prior to sled testing. Because IFD characteristics are highly susceptible to the environment they are in, a procured foam that has been exposed to different temperatures and humidity levels might have different IFD characteristics than those used for procurement. The foam certification (IFD) tests, conducted prior to testing, ensure that the foams are within the specified IFD ranges. The final drawing package incorporated by reference by this final rule also includes the Procurement and Certification specifications.

NHTSA established procurement specifications that differed from certification specifications for the same foam for the following reasons. First, NHTSA recognized that some foam suppliers use an industry standard test protocol, including specified sample sizes, when publishing foam specifications. Because these sample sizes are not the same size as what NHTSA will use for compliance testing, these data used to procure foam will not necessarily match the data on the actual foam samples used in NHTSA's compliance testing. Thus, while the procurement data are useful to identify potential foam that could be used in compliance tests, the agency made the specifications provided for procurement "for reference" as a guideline. The specifications that are binding for the purposes of compliance tests are those that meet the certification specifications. Those certification specifications are included in the table titled "Test Certification Specifications for 4 [inch] and 2 [inch] Foams" in drawings numbers 3021-233 and 3021-248 of the drawing package referenced in the updated standard by this final rule.

Second, given the variation in foam characteristics due to temperature and humidity changes, procurement specifications with tighter tolerances make it easier for NHTSA's OVSC to have suitable foams available for testing. A larger tolerance for testing with the purchased foam is desired so that more of the purchased foam is within specifications at the time of testing. The purchased foams will be exposed to different temperatures and humidity levels throughout their useful life, and, as a result, their IFD characteristics will vary throughout time. Having a wider IFD specification range is beneficial to ensure foams can be reasonably certified for

dynamic testing. Foams within the certification IFD specification ranges produced FMVSS No. 213 repeatable and reproducible dynamic test results.⁷⁸

IFD Test Procedure Consistency

In the December 2021 meeting with JPMA, JPMA recommended against creating a new unique procedure in Draft TP-213 “Laboratory Test Procedure for FMVSS 213 Child Restraint Systems” that deviates from ASTM D3574 and Woodbridge test methods. JPMA also recommended specifying the test method for certifying the foam blocks as either the latest version of ASTM D3574 (not the 2011 version) or a method matching how Woodbridge currently tests foam for certification at time of procurement.

Agency Response

JPMA suggests following Woodbridge specific IFD testing or ASTM D3574 without deviation. With regard to the Woodbridge-specific IFD, we cannot agree with the suggestion. NHTSA would not be able to follow the Woodbridge IFD testing methodology in all instances because Woodbridge is not the only source of foam. Each supplier will likely have different scientifically sound methods to evaluate IFD.

With regard to ASTM D3574, NHTSA agrees that referencing the ASTM D3574 standard in the drawing package where the foam specifications are indicated could improve consistency in foam testing. This final rule therefore incorporates by reference ASTM D3574 in the drawing package. However, following the ASTM D3574 standard without deviation is not possible. The foam sample specified in the ASTM D3574 (15 X 15 inches) differs from the foam sample size available from the seat cushion (19 X 28 inches) and seat back (22 X 28 inches). ASTM D3574 specifies sample thickness to be 4 inches whereas the seat back cushion of the updated standard seat assembly is only 2 inches thick. Also, the ASTM D3574 standard measures IFD values at 25% and 65%, while FMVSS No. 213 foam certification measures IFD of 50% (25% and 65% are measured only for reference). The drawing package notes where the

⁷⁸ Documented in technical report docketed in NHTSA-2020-0093-0029.

procedure differs from the ASTM standard. This is discussed in detail below in the paragraph entitled, “Comment on ASTM Reference.”

Response to Comment on Density

JPMA and Graco’s reference to foam density is unclear. JPMA and Graco referred to foam density and thickness as sources of IFD variation but all of JPMA’s data are specific to the variation in sample thickness. We did not see any data on density variation. We assume JPMA’s comment is trying to tie density to IFD, (i.e., a foam that is significantly less dense (softer) than the one we proposed might not yield the IFD values we proposed) as it is often thought that higher density foams are stiffer than lower density ones.⁷⁹ In response to that point, we do not believe a change to the density specification is needed, as our response to the comment on the IFD addresses the density aspect. As explained above, even with foam sample IFD differences, the dummy responses still produced results that were within 10 percent CV, indicating good repeatability.

4. Miscellaneous Issues

Comment on Industry-Produced Molds

JPMA suggested there should be a long-term effort, that NHTSA should support, whereby the CRS industry builds new molds for the standard seat assembly bottom and back foam blocks so the thickness, flatness and dimensions of the foam blocks can be controlled within tight specifications and tolerances. As it described this suggestion, JPMA believed that these changes would result in (1) consistent block thickness which will reduce dynamic test score variations, as well as a consistent block surface finish and surface profile; (2) alignment on how vehicle manufacturers mold the foam for vehicle seating surfaces; (3) all laboratories conducting FMVSS No. 213 testing on the updated standard seat assembly with the same foam blocks; (4)

⁷⁹ NHTSA recognizes that this is not always true as there is no direct correlation between density and stiffness (firmness). There can be low density foams with high stiffness. Link: <https://www.pfa.org/foam-performance/>

lower per piece cost as cutting and gluing operations would be eliminated; and (5) foam blocks produced with CRS Industry funded molds that would be accessible to everyone.

Agency Response

We are encouraged that the industry has thought of an approach where it could possibly develop a foam mold to procure foam more easily and consistently for FMVSS No. 213 testing purposes. However, the agency is cautious about an FMVSS No. 213 specification that may result in a single source for a component used in compliance testing, such as the standard seat assembly foam. NHTSA seeks for the foam to be available from multiple merchants. Also, the agency believes this approach of an industry-developed mold is an interesting one but there are factors the agency must thoroughly consider. For example, we believe the molds would have to be made available to everyone with no restrictions on use and would have to be used in a process anyone could use. NHTSA is also mindful that a mold would only be useful for a limited time, as the standard seat assembly is subject to updates.

Comment on Foam Procurement

Dorel comments that its conversations with Woodbridge indicated there may be challenges to meeting the foam specifications in the NPRM. Dorel urges NHTSA to confirm that the specifications are practicable and capable of being met by suppliers to avoid market disruption for inability to certify compliance.

In response, NHTSA does not know of any challenges Woodbridge has in meeting the specifications since they developed the specifications and have been successfully supplying the foam for several years. NHTSA also did market research and identified other sources from which the foam could be procured.⁸⁰ NHTSA procured these non-Woodbridge foams to confirm that

⁸⁰ Foam Feasibility Study Final Report - June 2018. Docket No. NHTSA-2020-0093-0012 at <https://regulations.gov/>.

the foam is not a single sourced item and that these foams have the same performance as the Woodbridge foam.⁸¹

Comment on ASTM Reference

Dorel states that there was a difference between the NPRM, and a 2015 NHTSA memorandum related to an ASTM reference. Dorel states that the NPRM⁸² references the 2003 update to the American Society for Testing and Materials (ASTM) D3574-03 “Standard Test Methods for Flexible Cellular Materials—Slab, Bonded, and Molded Urethane Foams” (ASTM D3574-03). The commenter notes the 2015 memo indicates the 2011 revision to that standard, ASTM D3574-11, is used to create the compression force deflection (CFD) specifications. Dorel asks NHTSA to clarify which version of the test standard it will reference.

In response, while the foam specifications were developed using, in general, the test methods of ASTM D3574-11, some aspects were adjusted. In response to the comment, NHTSA has added a note on the drawing package explaining that the full (seat pan and seat back) foam sample size and 50 percent indentation is tested in lieu of the ASTM D3574-11 requirement(s): “Foam IFDs are measured on the full-size sample, using the test methodology and apparatus described in ASTM Standard D3574-11 at 50% indentation. 25% and 65% are collected for reference only.” For instance, the required samples sizes for ASTM D3574 testing are to be 15 X 15 X 4 inches while the size of the seat pan foam is 19 X 28 X 4 inches and the seat back foam is 22 X 28 X 2 inches. NHTSA also makes CFD measurements at 25 percent (for reference only), 50 percent and 65 percent (for reference only), whereas the ASTM D3574 standard only makes CFD measurements at 25 percent and 65 percent. Therefore, NHTSA’s testing followed the ASTM D3574 test procedures generally but adjusted them for practical reasons.

The drawing package has been updated to reference the ASTM D3574-11 but with explanations of the differences with NHTSA testing, including those relating to sample size and

⁸¹ Loudon, A.E., Wetli, A.E. (2020 December). Evaluation of Foam Specifications for Use on the Proposed FMVSS No. 213 Test Bench. Washington, DC: National Highway Traffic Safety Administration. Docket No. NHTSA-2020-0093-0029, at <https://regulations.gov/>.

⁸² Preamble section III.c.5.i (85 FR 69395).

the additional 50 percent CFD measurement. The foam drawings 3021-233 and 3021-248 lists values for reference; the foam used in a specific test does not need to meet the 25 percent and 65 percent IFD values listed in these tables for the test to be valid. During its research program, NHTSA concluded that these values do not impact the results of the dynamic test but were helpful as reference points to monitor the condition of the foam. The 25 percent and 65 percent IFD values therefore were included in the drawing package for reference.

c. Means for Attaching a CRS to the Standard Seat Assembly

1. Seat Belts

FMVSS No. 213 currently states that CRSs are attached to the standard seat assembly with a Type 1 and not a Type 2 belt.⁸³ To ensure continued effective CRS performance in today's vehicles, NHTSA proposed to require all CRSs to meet the performance requirements of FMVSS No. 213 while attached to the seat assembly with a Type 2⁸⁴ (lap/shoulder belt). The NPRM proposed to amend the CRS frontal collision test by, among other things, specifying that NHTSA would use the Type 2 belt to attach child restraints to the seat assembly in a test. With the prevalence of Type 2 belts in the rear seats of vehicles sold today, the NPRM proposed to delete, as obsolete, the current provisions to use the Type 1 belt. NHTSA proposed the change with the view that testing CRSs with the type of seat belt caregivers are likely to use better ensures that the test is representative of real-world conditions. Also, the agency believed the change to a Type 2 belt would be inconsequential as test data do not indicate any significant difference in

⁸³ FMVSS No. 213 S5.3.2. See also NHTSA, Test Procedures, TP-213-10, February 16, 2014. Note that belt-positioning (booster) seats are currently tested with a Type 2 belt.

⁸⁴ The Type 1 and Type 2 seat belt assemblies in the current and updated standard seat assemblies simulate these seat belt types in vehicles, by having anchorage locations representative of vehicles, and webbing that conforms with FMVSS No. 209. The configuration and webbing of the seat belt assemblies and location on FMVSS No. 213's standard seat assembly reproduce relevant aspects of the vehicle environment in a manner that is controlled for compliance testing purposes. These seat belt types in the standard seat assembly do not meet all FMVSS No. 209 provisions as regards having retractor buckles, other fasteners, or hardware designed for installing such seat belt assembly, but those differences are minor and generally do not affect CRS performance. However, the belt retractor on the standard seat assembly is fixed, which differs from retractors on real-world vehicles that allow some spooling-out of webbing before locking in a crash-imminent situation. As discussed in sections below, NHTSA has research underway to develop a retractor that better replicates real-world retractors, that could provide a more thorough assessment of child restraint system performance in the real world. NHTSA plans to develop the retractor and eventually propose the retractor in a future rulemaking.

performance in current child restraint designs when installed using a Type 1 versus a Type 2 belt.⁸⁵

All commenters support the proposal to use Type 2 belts to anchor child restraints to the standard seat assembly. The National Safety Council, Consumer Reports, Volvo, and Salem-Keizer Public Schools support testing of CRSs with the use of Type 2 belts as they are more representative of the vehicle fleet. However, while supporting the use of Type 2 belts, SBS and SRN also strongly oppose removing the Type 1 belt testing specification in FMVSS No. 213. SBS and SRN urge NHTSA to retain the Type 1 belt test, at least for a while longer, to meet the needs of persons who may own vehicles that do not have Type 2 belts in rear seats.

After reviewing the comments, we have decided to adopt the proposed provisions about including Type 2 belts on the updated seat assembly and testing child seats while anchored with the Type 2 belts. Also, as discussed in detail in a section below, this final rule retains the Type 1 belt test until September 1, 2029. Thus, this final rule includes specifications for Type 1 and Type 2 belts on the new standard seat assembly.

Type 1 Belt Specifications

The specifications for the Type 1 (2-point) belt anchorages are the same as the Type 1 belt anchorages of the Type 2 (3-point) seat belts. Although the Vehicle Rear Seat Study⁸⁶ shows that center vehicle seat Type 1 seat belt anchorages (where Type 1 seat belts are available), are closer together than in outboard vehicle seats, narrower spacing can cause potential interference with wide CRSs. This interference could affect the setup of the CRS on the standard seat assembly. While the average spacing between the anchorages in a rear center seating position in the vehicle fleet is 355 mm, the spacing ranged between 232 mm to 455 mm. The lap belt anchorages of the Type 2 seat belt anchorages in the standard seat assembly have a spacing of

⁸⁵ See results of test numbers 8917, 8922, 8919, 8923, 8929, and 8931 in Table 11 and test numbers 8917, 8922, 8919, and 8923 in Table 12 of the NPRM.

⁸⁶ NHTSA-2020-0093-0006

450 mm. While this spacing is greater than the average spacing of the lap belt anchorages of rear center seats in the vehicle fleet, it is still within the range found in the vehicle fleet.

Type 2 Belt Specifications

The agency has adopted specifications for the Type 2 belt as proposed in the NPRM. The agency determined the location of the anchorages based on requirements of FMVSS No. 210, “Seat belt anchorages,” and the data from the Vehicle Rear Seat Study. We also adjusted the anchorage placement to ensure a compliance test could be conducted without interference between the seat belt and the vehicle seat assembly, or the child restraint and a seat belt anchorage. Five commenters (the National Safety Council, Salem-Keizer schools, Volvo, Safe Ride News and Consumer Reports) commented in support of the proposal to incorporate Type 2 belts into FMVSS No. 213’s protocols. No commenter opposes the inclusion of Type 2 belts into FMVSS No. 213. NHTSA will incorporate a Type 2 belt into FMVSS No. 213 and the standard seat assembly as proposed.

Clarifying Belt Webbing Specifications

Some CRS manufacturers took the opportunity to comment on the webbing used for the standard seat assembly’s seat belts. Currently, S6.1.1.(c) specifies that the webbing must comply with FMVSS No. 209 and have a width of not more than 2 inches.⁸⁷ Graco notes that the current Compliance Test Procedure, TP-213-10, specifies webbing with 5 panels but that the 5-panel webbing is not specified in FMVSS No. 213, as Graco believes it should be. The commenter also notes the Research Test Procedure that was used to develop the 2020 NPRM used webbing with 7 panels. JPMA and Britax note that, as 5-panel webbing is no longer available, FMVSS No. 213 should reflect the mechanical properties of the webbing. Graco believes that FMVSS No. 209 permits significant variation in elongation, which can affect FMVSS No. 213 test outcomes.

⁸⁷ FMVSS No. 209, “Seat belt assemblies,” establishes elongation requirements (S4.2(c) when the webbing is subjected to a load of 11,120 Newtons (N). The elongation requirements vary depending on the different assembly types. In general, the webbing must not extend to more than the following elongation when subjected to the specified forces in accordance with the procedure specified in FMVSS No. 209 S5.1(c): Type 1 seat belt assembly - 20 percent at 11,120 [Newtons (N)]; Type 2 seat belt assembly 30 percent at 11,120 N for webbing in pelvic restraint and 40 percent at 11,120 N for webbing in upper torso restraint.

Graco recommends that FMVSS No. 213 should provide a narrow range for the elongation under load to ensure test consistency.

Agency Response

FMVSS No. 213 does not specify the number of panels for the standard seat assembly's seat belt webbing, and we do not believe it is necessary to do so. NHTSA used 7-panel webbing that was certified to applicable requirements in FMVSS No. 209 throughout the development of the proposed updates to FMVSS No. 213, as it is now more commonly used in the field. It is true that the current OVSC Compliance Test Procedure for FMVSS No. 213, TP-213-10, specifies 5-panel webbing and that the Research Test Procedure specifies a 7-panel webbing. However, neither contradicts the standard because both types of webbing were certified to applicable requirements of FMVSS No. 209. Furthermore, as we learned from reaching out to a seat belt supplier/manufacturer and from tests we conducted (described below), the number of panels does not affect the strength or elongation of the webbing. The number of panels is simply a matter of manufacturer preference.

NHTSA conducted some elongation tests on seat belt webbing having different number of panels and different specifications for percent elongation.

Table 1. Elongation testing of 7 seat belt webbing models.

| Webbing | Elongation% | Break Load (N) | Maximum Displacement (mm) |
|---------------------|--------------------|-----------------------|----------------------------------|
| Autoliv 6% 3-Panel | 6.3 | 27,842.6 | 184.7 |
| Autoliv 6% 3-Panel | 6.4 | 27,753.5 | 180.4 |
| Autoliv 6% 3-Panel | 6.3 | 27,746.6 | 187.8 |
| Autoliv 10% 5-Panel | 9.7 | 28,762.0 | 238.0 |
| Autoliv 10% 5-Panel | 9.6 | 28,828.0 | 237.5 |
| Autoliv 10% 5-Panel | 9.5 | 29,103.8 | 246.2 |
| Autoliv 15% 6-Panel | 12.4 | STROKE MAXED OUT | 260.0 |
| Autoliv 15% 6-Panel | 12.5 | STROKE MAXED OUT | 260.0 |
| Autoliv 15% 6-Panel | 12.8 | STROKE MAXED OUT | 260.0 |
| MGA 5- Panel | 8.4 | 26,827.4 | 201.3 |
| MGA 5- Panel | 8.5 | 27,587.1 | 212.5 |
| MGA 5- Panel | 6.7 | 26,600.2 | 200.5 |

| | | | |
|-----------------------------|-----|----------|-------|
| CALSPAN Compliance 5 -Panel | 6.8 | 32,511.1 | 207.0 |
| CALSPAN Compliance 5 -Panel | 6.5 | 33,045.7 | 200.9 |
| CALSPAN Compliance 5 -Panel | 6.5 | 33,630.9 | 208.9 |
| CALSPAN R&R 7-Panel | 8.2 | 32,187.7 | 224.0 |
| CALSPAN R&R 7-Panel | 8.0 | 32,410.2 | 223.1 |
| CALSPAN R&R 7-Panel | 8.2 | 32,372.3 | 220.3 |
| VRTC R&R 7-Panel | 7.2 | 29,244.8 | 216.0 |
| VRTC R&R 7-Panel | 7.3 | 28,615.1 | 217.6 |
| VRTC R&R 7-Panel | 7.4 | 29,322.2 | 222.5 |

Test data in Table 1 show that webbing can be manufactured to different percent elongation specifications independent of the number of panels, and therefore, specifying the number of panels would be meaningless. Because the number of panels is immaterial, NHTSA may change TP-213 to remove any specification of a panel number. This addresses the comments by JPMA, Graco and Britax regarding the discrepancy of the number of panels in the webbing and the difficulty purchasing the 5-panel webbing. What matters most about the webbing in this context is the elongation characteristics, not the number of panels.

Graco states that the proposed regulatory text in the NPRM only requires that the webbing meet FMVSS No. 209 requirements without defining the desired mechanical properties. NHTSA disagrees that the regulatory text does not specify the webbing's mechanical properties, as FMVSS No. 209 S4.2, referenced in FMVSS No. 213, specifies the mechanical properties of the webbing.

Graco recommends narrowing the elongation limits and we agree to consider this for the OVSC Compliance Test Procedure (TP-213). NHTSA recognizes that the elongation limits in FMVSS No. 209 range widely, 20 percent, 30 percent and 40 percent depending on type of seat belt assembly. While Graco suggests FMVSS No. 213 should specify a narrow range for elongation under load, it did not provide data demonstrating how different elongation specifications within FMVSS No. 209 affect FMVSS No. 213 test outcomes. Nonetheless, while FMVSS No. 209 contains wide elongation ranges, the vehicle manufacturers usually use ranges of 6-15 percent. Webbing of lower elongation percentages would be difficult to produce and

procure, and could be too stiff causing potential injuries as it is slowing down the occupant more abruptly. Elongation ranges over 15 percent could create excessive excursion during a crash, which could result in an undesirable outcome for the occupant (i.e., it will be more likely for the occupant to contact vehicle structures, like the instrument panel or steering wheel). The agency will consider incorporating in TP-213 a narrower elongation range than is currently specified in the test procedure, to reflect belt webbing in today's vehicles. The agency tentatively concludes that a narrower elongation range would better represent the real-world crash environment, as it would be a range commonly found in vehicles.

Further, NHTSA notes that, in practice, the elongation values used to develop this final rule were much narrower than that specified in FMVSS No. 209. NHTSA did not collect the specific elongation characteristics for the webbing used during FMVSS No. 213 development testing. However, webbing that was recently procured by VRTC for testing the updated standard seat assembly is consistent with what vehicle manufacturers use (6-15 percent). So while the elongation ranges in FMVSS No. 209 are wide, in practice webbing with much smaller elongation ranges are used.

2. Child Restraint Anchorage System

The specifications for the child restraint anchorage system are the same as those proposed in the NPRM. These include the locations for the lower anchorages and for the top tether anchorage. There were no comments opposing the proposed specifications. This final rule adopts the proposal for the reasons provided in the NPRM.

d. Repeatability and Reproducibility of Test Results

After NHTSA developed the updated standard seat assembly, the agency contracted with three different test labs to build the updated standard seat assembly and evaluate the repeatability and reproducibility of the FMVSS No. 213 sled test. NHTSA's repeatability and reproducibility evaluation of the updated standard seat assembly is discussed in more detail in the agency's technical report titled, "FMVSS No. 213 Frontal Repeatability and Reproducibility Evaluation,"

(August 2023). A copy of the report is found in the docket for this final rule. The three test labs were Calspan, the Medical College of Wisconsin (MCW) and the Transportation Research Center (TRC).

Calspan and MCW fabricated an updated standard seat assembly based on a drawing package provided by NHTSA. VRTC provided TRC with an up-to-date standard seat assembly to use as a baseline in the assessment. After building an updated standard seat assembly, Calspan and MCW provided key measurements of their updated standard seat assemblies for NHTSA to compare to the drawing package. The labs also provided data of foam certifications⁸⁸ showing the repeatability and reproducibility of the new foam cushion IFD test procedure described in Appendix C of the 2020 “Evaluation of Foam Specifications for Use on the Proposed of the FMVSS No. 213 Test Bench”.⁸⁹

Each lab also conducted sled testing to evaluate the repeatability and reproducibility of the overall updated standard seat assembly and the test procedure used in the assessment. Each lab conducted several sets of repeat tests with the same child restraints systems, which provided the data needed to evaluate the overall repeatability and reproducibility of the updated standard seat assembly, test procedure, and overall system-level sled test. When comparing within each lab and across all three labs, most injury responses had a CV under 10 percent,⁹⁰ indicating that the updated sled test and related procedures are repeatable and reproducible.

Comment Received

Graco states that it conducted a statistical analysis of data it gathered during testing⁹¹ at two labs with a HIII-6YO dummy in seven different models of belt-positioning seats and one

⁸⁸ Data is documented in the “FMVSS No. 213 Frontal Repeatability and Reproducibility Evaluation” technical Report.

⁸⁹ Loudon, A.E., Wetli, A.E. (2020 December). Evaluation of Foam Specifications for Use on the Proposed FMVSS No. 213 Test Bench. Washington, DC: National Highway Traffic Safety Administration.

⁹⁰ Coefficient of Variation (CV) is a measure of the dispersion of data points in a data series around the mean value. CV is computed as a percentage of the mean and is computed for a data series as the standard deviation (σ) for the data series divided by the mean (μ) of the data series times 100. $CV = (\sigma/\mu) \times 100$.

⁹¹ Graco performed 348 dynamic tests using different CRS models (18) and types (rear-facing, forward-facing and booster seats) at two labs: Calspan (Buffalo, NY) and Graco (Atlanta, GA). More details on the testing can be found at Graco’s comment (Docket No. NHTSA-2020-0093-0035 at <https://www.regulations.gov/>).

model of a child restraint installed with a Type 2 belt system. Graco states that the test results show that the HIC36 scores have very high variation between and within the two labs, to the degree that they would fall into the “needs improvement” category. The CV for the other injury criteria were mostly in the “excellent” range and a few chest resultant scores in the “good” range.

Graco states it further assessed if the high CV results for HIC36 are a function of lab-to-lab variation by evaluating the HIC36 scores from just the units tested at Calspan. The commenter states that half of the eight CRSs have high variability (CV > 10 percent) and another showed marginally acceptable variability (CV exactly 10 percent). The commenter argues that its findings are supported by some of the findings in Table 4 of a Calspan’s R&R Report (sponsored by NHTSA).⁹² The table is titled, “Reproducibility of the Graco Affix 6-year-old with Type 2 belt restraint.” Graco notes that the chest acceleration results have a mean of 51.5 g at Calspan and a mean of 58.8 g at VRTC, yet the Calspan R&R Report suggests - relying on a CV of 4.2 percent - that this information supports a test process that is rated “excellent” for its repeatability and reproducibility across laboratories. The commenter acknowledges that intra-laboratory testing is consistent. “However, when the data is taken as a whole the mean is 54.6 g [NHTSA notes that the correct value in the report is 55.1g] and the standard deviation is 4.1 g, and the expected failure rate given these data is approximately 10 percent of units tested, which suggests an unacceptable process.”

Graco also referenced Table 5 of a NHTSA R&R report that shows a difference in the mean values for head excursion between the two labs of 23.7 mm, although the CV was determined to be 2.7 percent, indicating excellent repeatability and reproducibility. The commenter states, “Again, this illustrates that lab-to-lab variation does exist and can materially affect test outcomes.”

⁹² Table 4, Maltese, M.R., Horn, W. “Repeatability and Reproducibility of the Updated FMVSS No. 213 Frontal Standard Seat Assembly”. October 2019. Report Number: 213R&R-CAL-19-018R1. Docket No. NHTSA-2020-0093-0011 at <https://www.regulations.gov/>

Graco states that, as a result of these tests and its review of the NHTSA report, it is concerned that the representative proposed standard seat assembly has not shown good repeatability and reproducibility in its current state and that improvements must be made to ensure more consistent test results. Graco suggests changes to improve the R&R of the test bench and the test method. These changes are discussed in other sections of this preamble.

Agency Response

NHTSA disagrees with Graco's view about the R&R of the sled. As discussed above, NHTSA performed repeatability and reproducibility tests at the three laboratories used (Calspan, MCW, and TRC) on a variety of CRS models in different configurations using different size dummies (see Table 2) to help NHTSA determine the R&R of the proposed test equipment and test procedure. This section will discuss this testing in more detail showing that the proposed equipment and test procedure are R&R, as well as responding to some of the commenter's concerns about R&R.

The standard seat assemblies in the three laboratories used for the repeatability and reproducibility testing were in accordance with the specifications of this final rule.⁹³ The sled acceleration pulses used in the three laboratories were within the specified corridor of this final rule as shown in Figure 2. The three laboratories used acceleration-based sleds (HYGE Sled or SERVO Sled). More details are available in the tables found in Appendix A to the Preamble – Reproducibility Test Results.

⁹³ Testing was done with the proposed standard seat assembly; however, only minor changes were done to the drawings of the standard seat assembly that would have no effect on the performance of these tests.

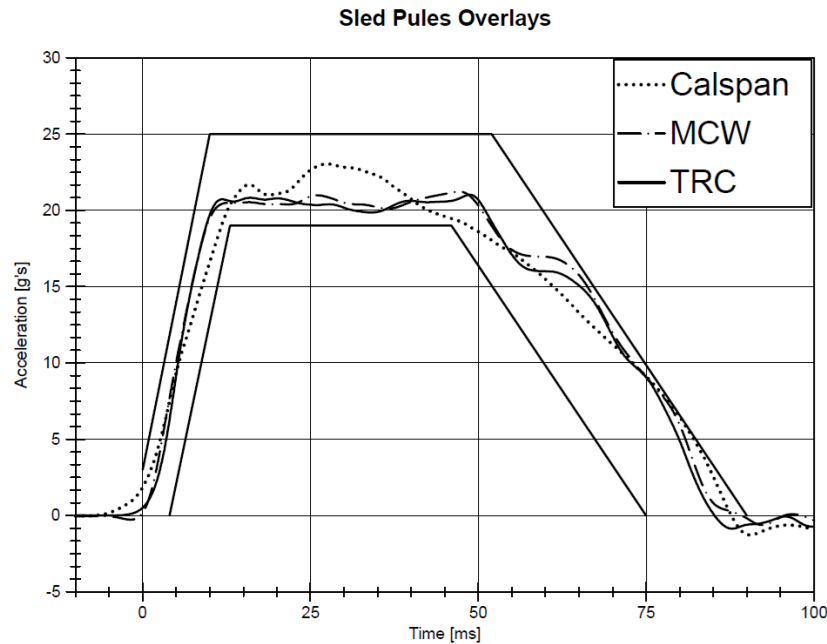

Figure 2. Pulse comparison in three laboratories and FMVSS No. 213 corridor.

NHTSA calculated the CV for the applicable FMVSS No. 213 injury criteria for the repeat tests to evaluate in-lab repeatability and for all the tests at the three labs to evaluate reproducibility. Since a new CRS is used for each test, the variability in test results for a CRS model is due to the variability in the construction of the CRS, the CRS design, test equipment, test conditions and test procedure.

The CV for the seat back angle measure in the tests of CRS used rear-facing was less than 10 percent for repeatability and reproducibility. The CV for head and knee excursions in tests of forward-facing CRSs and belt-positioning seats were also less than 10 percent for repeatability and reproducibility. The CV for Chest Acceleration repeatability and reproducibility was less than 10 percent for all the CRS models tested in all three laboratories.

The CV for HIC36 repeatability was less than 10 percent in all but one CRS configurations tested. The HIC36 CV for the Evenflo SureRide (6YO-Forward-facing (FF) CRS) tests conducted at MCW was 10.3 percent. The CV for HIC36 reproducibility in all models was

less than 10 percent except for the Harmony Defender 360⁹⁴ (CV=16.6 percent) and the Chicco Key Fit (CV=12.1 percent).

Table 2. CV Percent Values for Repeatability and Reproducibility Testing

| Evenflo Embrace 35 - CRABI - Infant - LA Only | | | | |
|--|--------|-------------|--------------------|-----------------|
| CV% | | | | |
| Test Facility | QTY | HIC36 | Chest Acceleration | Seat Back Angle |
| Calspan | n=3 | 2.3 | 1.3 | 0.9 |
| MCW | n=3 | 3.3 | 4.4 | 3.8 |
| TRC | n=3 | 5.6 | 9.4 | 3.4 |
| All | n=9 | 5.6 | 5.7 | 8.7 |
| Chicco Key Fit - CRABI - Infant - LA Only | | | | |
| CV% | | | | |
| Test Facility | QTY | HIC36 | Chest Acceleration | Seat Back Angle |
| Calspan | n=3 | 5.1 | 0.7 | 2.3 |
| MCW | n=1 | - | - | - |
| TRC | n=1 | - | - | - |
| All | n=5 | 12.1 | 1.1 | 6.7 |
| | SigmaL | 13.1 | - | - |
| Evenflo Embrace 35 - CRABI - Infant - SB3PT | | | | |
| CV% | | | | |
| Test Facility | QTY | HIC36 | Chest Acceleration | Seat Back Angle |
| Calspan | n=3 | 0.9 | 1.3 | 1.7 |
| MCW | n=3 | 3.8 | 2.7 | 2.0 |
| ALL | N=6 | 7.6 | 5.6 | 3.0 |
| Cosco Scenera Next - HIII 3YO - RF⁹⁵ - LA Only | | | | |
| CV% | | | | |
| Test Facility | QTY | HIC36 | Chest Acceleration | Seat Back Angle |
| Calspan | n=3 | 2.4 | 3.7 | 2.0 |
| MCW | n=3 | 1.5 | 2.4 | 0.9 |
| TRC | n=3 | 9.5 | 3.1 | 2.4 |
| All | n=9 | 6.2 | 3.1 | 1.9 |
| Graco MyRide 65 - HIII 3YO - RF – Type 2 | | | | |
| CV% | | | | |
| Test Facility | QTY | HIC36 | Chest Acceleration | Seat Back Angle |

⁹⁴ Using the HIII-3-Year-Old in a forward-facing (FF) CRS.

⁹⁵ RF means rear-facing.

| | | | | | |
|--|--------|-------------|--------------------|----------------|----------------|
| Calspan | n=3 | 3.4 | 1.7 | 1.1 | |
| MCW | n=3 | 3.0 | 2.9 | 1.0 | |
| TRC | n=3 | 2.2 | 1.9 | 7.5 | |
| All | n=9 | 8.3 | 2.2 | 7.0 | |
| Cosco Scenera Next - HIII 3YO - FF⁹⁶ – LATCH | | | | | |
| CV% | | | | | |
| Test Facility | QTY | HIC36 | Chest Acceleration | Head Excursion | Knee Excursion |
| Calspan | n=3 | 3.6 | 3.4 | 0.6 | 1.7 |
| MCW | n=3 | 8.3 | 1.3 | 1.8 | 0.3 |
| TRC | n=3 | 2.9 | 2.5 | 0.5 | - |
| All | n=9 | 8.9 | 4.4 | 1.8 | 1.4 |
| Harmony Defender 360 - HIII 3YO - FF – Type 2&T | | | | | |
| CV% | | | | | |
| Test Facility | QTY | HIC36 | Chest Acceleration | Head Excursion | Knee Excursion |
| Calspan | n=1 | - | - | - | - |
| MCW | n=3 | 3.1 | 2.6 | 1.0 | 0.5 |
| TRC | n=2 | - | - | - | - |
| All | n=6 | 16.6 | 5.9 | 2.0 | 1.6 |
| | SigmaL | 9.8 | - | - | - |
| Britax Marathon Clicktight- HIII 6YO - FF – LA Only | | | | | |
| CV% | | | | | |
| Test Facility | QTY | HIC36 | Chest Acceleration | Head Excursion | Knee Excursion |
| Calspan | n=3 | 6.5 | 5.1 | 3.3 | 1.2 |
| MCW | n=1 | - | - | - | - |
| TRC | n=1 | - | - | - | - |
| All | n=5 | 6.3 | 6.5 | 0.7 | 2.2 |
| Evenflo SureRide - HIII 6YO - FF – LATCH | | | | | |
| CV% | | | | | |
| Test Facility | QTY | HIC36 | Chest Acceleration | Head Excursion | Knee Excursion |
| Calspan | n=0 | - | - | - | - |
| MCW | n=3 | 10.3 | 3.4 | 3.5 | 0.4 |
| | SigmaL | 15.3 | | | |
| TRC | n=3 | 4.8 | 0.3 | 1.0 | 0.6 |
| All | n=6 | 9.1 | 2.9 | 2.7 | 1.3 |
| Graco Nautilus 65 - HIII 6YO - FF - Type 2 | | | | | |
| CV% | | | | | |
| Test Facility | QTY | HIC36 | Chest Acceleration | Head Excursion | Knee Excursion |

⁹⁶ FF means forward-facing.

| | | | | | |
|---|-----|--------|--------------------|----------------|----------------|
| Calspan | n=3 | 3.5 | 1.3 | 1.7 | 0.7 |
| MCW | n=3 | 4.9 | 5.2 | 0.7 | 0.7 |
| TRC | n=3 | 2.2 | 1.9 | 1.2 | 1.1 |
| All | n=9 | 8.8 | 3.5 | 2.0 | 1.1 |
| Britax Frontier Clicktight - HIII 10YO - FF - Type 2&T | | | | | |
| CV% | | | | | |
| Test Facility | QTY | HIC36* | Chest Acceleration | Head Excursion | Knee Excursion |
| Calspan | n=2 | n/a | - | - | - |
| MCW | n=1 | n/a | - | - | - |
| TRC | n=3 | n/a | 5.1 | 1.0 | 0.5 |
| All | n=6 | n/a | 6.1 | 1.6 | 1.3 |
| Cosco Pronto HB - HIII 6YO - BPS - Type 2 | | | | | |
| CV% | | | | | |
| Test Facility | QTY | HIC36 | Chest Acceleration | Head Excursion | Knee Excursion |
| Calspan | n=3 | 3.4 | 7.0 | 0.8 | 0.7 |
| MCW | n=3 | 6.5 | 5.4 | 3.4 | 0.6 |
| TRC | n=3 | 3.6 | 1.0 | 0.4 | 0.7 |
| All | n=9 | 7.4 | 9.5 | 3.7 | 1.6 |
| Graco Affix -HIII 6YO BPS -Type 2 | | | | | |
| CV% | | | | | |
| Test Facility | QTY | HIC36 | Chest Acceleration | Head Excursion | Knee Excursion |
| Calspan | n=3 | 4.7 | 2.0 | 1.6 | 0.2 |
| MCW | n=3 | 5.5 | 5.2 | 2.7 | 3.5 |
| TRC | n=3 | 8.1 | 1.2 | 2.3 | 0.4 |
| All | n=9 | 8.9 | 3.5 | 2.6 | 2.4 |
| Harmony Youth NB - HIII 6YO - BPS - Type 2 | | | | | |
| CV% | | | | | |
| Test Facility | QTY | HIC36 | Chest Acceleration | Head Excursion | Knee Excursion |
| Calspan | n=3 | 3.4 | 1.4 | 1.1 | 1.8 |
| MCW | n=3 | 4.5 | 1.7 | 1.0 | 0.9 |
| TRC | n=3 | 9.4 | 2.7 | 2.3 | 0.9 |
| All | n=9 | 7.9 | 2.9 | 1.9 | 1.1 |
| Evenflo Big Kid LX HB - HIII 10YO - BPS - Type 2 | | | | | |
| CV% | | | | | |
| Test Facility | QTY | HIC36* | Chest Acceleration | Head Excursion | Knee Excursion |
| Calspan | n=3 | n/a | 1.6 | 1.1 | 4.1 |
| MCW | n=3 | n/a | 3.5 | 1.8 | 1.2 |

| | | | | | |
|-----|-----|-----|-----|-----|-----|
| TRC | n=3 | n/a | 1.0 | 0.6 | 0.1 |
| All | n=9 | n/a | 3.4 | 3.5 | 3.2 |

**HIC36 when using the HIII-10YO dummy is not an injury measure used in FMVSS No. 213.*

The Harmony Defender 360 tested in the forward-facing with internal harness CRS configuration, using the HIII-3YO dummy had good repeatability values, but the CV exceeded 10 percent for HIC36 reproducibility. The Chicco Key Fit infant carrier tested in the rear-facing with internal harness CRS configuration, using the CRABI-12MO dummy had good repeatability values, but the CV exceeded 10 percent for HIC36 reproducibility. The CV for HIC36 repeatability for the Evenflo SureRide (forward-facing CRS with internal harness with HIII-6YO) exceeded 10 percent in one laboratory (MCW). We note that the HIC36 values for these CRSs were under 500 which is less than 50 percent of the performance limit (1000). Because CV is calculated by dividing the standard deviation by the average values, the CV appears to be larger for lower average values of HIC36 than for higher average HIC36 values.⁹⁷

For each metric with a higher than 10 percent CV, we calculated the substantiveness of the variation relative to the IARV or performance limit. Sigma-to-Limit (SigmaL, σ_L) (see Equation 1) results above 2.0, would indicate at least two standard deviations between the average response and the IARV or performance limit. Responses with a Sigma-to-Limit greater than two identify “good” levels of variation that are unlikely to cross the IARV or performance limit.

$$\text{Sigma-to-Limit (SigmaL, } \sigma_L) = ((\text{Limit} - \bar{x}))/\sigma \quad \text{Equation 1}$$

The HIC36 CV percent for repeatability for the Evenflo SureRide (6YO-forward-facing CRS) tests conducted at MCW was 10.3 percent with a Sigma-to-limit value of 15.3. The CV for HIC36 reproducibility in the Harmony Defender 360⁹⁸ was 16.6 percent with a sigma-to-limit value of 9.8 and in the Chicco Key Fit was 12.1 with a sigma-to-limit value of 13.1. This means

⁹⁷ This is considered a limitation in the use of %CV. Therefore, NHTSA also considers the average measures with respect to the allowable performance measure when assessing repeatability and reproducibility using %CV.

⁹⁸ Using the HIII-3-Year-Old in a forward-facing (FF) CRS.

that while these CRSs had a CV percent above 10, it is unlikely that the observed variability would cause a CRS to cross the IARV established in the standard.

Graco commented that half of their eight CRSs having high in-lab variability (CV greater than 10 percent) and the high HIC variability values in tests conducted at different labs. Graco did not provide the HIC values for those tests but we would expect that HIC values for those tests were low (around or below 500) where, just like NHTSA's tests with the Harmony Defender 360 and Evenflo SureRide, CV appears to be larger for lower average values of HIC36 than for higher ones.

These results show the updated standard seat assembly design and corresponding test procedures are repeatable and reproducible. The CV analysis is a practical approach to evaluating R&R of the whole system (test article, test equipment, test environment, and test procedure). While we cannot extract the variability introduced by the different sources of variability (for example variation in acceleration pulses, test dummies, CRS build), results showed acceptable CV values (less than 10 percent) or marginally above 10 percent.

In further response to Graco's concern that its tests had HIC values exceeding 10 percent CV, it is important to note that assessment of repeatability based on CV values is a methodology established to assess the repeatability and reproducibility of anthropomorphic test devices in qualification testing.⁹⁹ Per this assessment, CV values of dummy responses in the qualification tests of less than or equal to 10 percent are considered acceptable to excellent in repeatability and reproducibility. Note, however, that these qualification tests typically involve an impact by a tool to a specific dummy part (e.g., head, thorax, pelvis, right arm, left leg), and so the CV values only evaluate the variability of a specific dummy response. In contrast, the CV values of dummy responses in the frontal impact sled test includes variability at a system level (whole body dummy responses in different child restraint systems on a dynamic sled). Therefore, strict

⁹⁹ Rhule, D., Rhule, H., & Donnelly, B. (2005). The process of evaluation and documentation of crash test dummies for Part 572 of the Code of Federal Regulations. 19th International Technical Conference on the Enhanced Safety of Vehicles, Washington, DC, June 6-9, 2005. <https://www-esv.nhtsa.dot.gov/Proceedings/19/05-0284-W.pdf>

adherence to the acceptable limit of CV used in the dummy qualification tests may be setting the bar exceptionally high when evaluating system level performance. Nevertheless, the reproducibility evaluation shows it is acceptable in 13 of the 15 CRS configurations evaluated, as shown in Table 2.

Graco notes that the testing published during the NPRM showed “excellent” repeatability and reproducibility for head excursions (CV = 2.7 percent) yet there was a difference in the data of 23.7 mm. As discussed above, the CV “ratings” were established to evaluate dummy responses in qualification tests, so we do not have a defined scale of what CV ratings would apply for a more complex system like the frontal sled test. However, a 23.7 mm difference is less than 3 percent of the head excursion performance limit. A 3 percent difference in performance does not amount to an unreasonable degree of variability in a complex system with multiple variability sources. Graco noted that the chest acceleration data reported in the NPRM showed a CV of 4.2 for reproducibility tests with the Graco Affix. NHTSA considers a chest acceleration CV of 4.2 percent as low and representing good repeatability and reproducibility of the dummy measure. NHTSA assures the safety of motor vehicles and motor vehicle equipment under the self-certification framework of the Safety Act through its assessment of the manufacturers’ basis for certification. Manufacturers self-certify their products knowing that NHTSA can perform its own testing following the manufacturers’ certification. Accordingly, they strive to produce vehicles and equipment that will meet the FMVSS performance requirements when tested by NHTSA. We cannot comment on Graco’s test results as we do not have enough information on the tests to make any determination on the sources of the increased CV values. The data available to NHTSA, however, show variability as controlled to a small and reasonable level.

In addition to the above tests, NHTSA tested 3 additional CRS models and installation configurations 3 times to further evaluate the in-lab repeatability. All these tests had injury

measures with CV values under 10. More detailed tables are available in Appendix A and Appendix B to the preamble.¹⁰⁰

Table 3. CV Percent Values for Repeatability Testing

| Cosco Scenera Next – Rear-facing- 12-Month-Old – Lower Anchor Only Installation | | | | | |
|---|------------|--------------|---------------------------|----------------------------|----------------------------|
| | QTY | HIC36 | Chest Acceleration | RF Angle | |
| | | | | CV | |
| Calspan | 3 | 5.0 | 6.6 | 3.3 | |
| Maxi Cosi Pria¹⁰¹ HIII-10YO Forward-facing CRS – Type 2 Belt Installation | | | | | |
| | QTY | HIC36 | Chest Acceleration | Head Excursion (mm) | Knee Excursion (mm) |
| | | | | | |
| Calspan | 3 | n/a | 3.9 | 0.8 | 1.2 |
| Harmony Youth HIII-10YO – Belt-Positioning Seat – Type 2 Belt Installation | | | | | |
| | QTY | HIC36 | Chest Acceleration | Head Excursion (mm) | Knee Excursion (mm) |
| | | | | | |
| TRC | 3 | n/a | 0.9 | 1.9 | 1 |

In conclusion, NHTSA’s data shows that good R&R can be achieved by the proposed test equipment and test procedures. While CV analysis cannot identify the different sources of variability, the system as a whole, including variability sources that are independent of the system we are evaluating (e.g., CRS design, pulse variation, etc.), showed good R&R and NHTSA is proceeding to adopt the proposed standard seat assembly with minor changes based on comments. These changes are discussed in another section of this preamble.

e. Miscellaneous Issues

¹⁰⁰ Reports on this testing will be docketed with the final rule. (1) Horn, W. and Maltese, M.R. “Phase 2 Summary Report FMVSS No. 213 Proposed Updated Frontal Standard Seat Assembly” Calspan. September 2020, (2) Hauschild, H.W. and Stemper, B. “Final Summary Report for FMVSS 213 R&R Testing Updated Frontal Standard Seat Assembly” MCW. December 2020, (3) Hauschild, H.W. and Stemper, B. “Final Summary Report of FMVSS 213 R&R Testing Updated Frontal Standard Seat Assembly” MCW. November 2021.

¹⁰¹ Maxi Cosi 85. We note that on August 24, 2021 Dorel issued a recall on the Maxi Cosi 85 CRS due to increased risk of injury in the event of a crash if the seat is installed with only the lap belt. The Maxi Cosi Pria 85 units tested in this R&R study were included in the scope of this recall; however, the test performed in the R&R study utilized a lap and shoulder belt installation which differed than the installation method identified in the recall. See <https://static.nhtsa.gov/odi/rcl/2021/RCLRPT-21C003-8612.PDF>

1. Addition of an ATD Head Protection Device (ATDHPD)

The drawing package of the updated standard seat assembly adopted by this final rule depicts use of an ATDHPD, at NHTSA's option, as a housekeeping measure to prevent damage to NHTSA's dummies in some tests. The ATDHPD, which NHTSA developed, is a metal part that is padded on one side that mounts on the seat back structure of the standard seat assembly. It is positioned behind the head area of a dummy seated in a CRS on the standard seat assembly.¹⁰² Testing with the proposed standard seat assembly showed the back of the head of the HIII-6YO and HIII-10YO dummies directly hitting the metal frame on the top of the seat back when the dummy is rebounding from the frontal loading. With repeated testing, this impact will likely damage the head of the dummies. Use of the ATDHPD, which is easily installed and removed, prevents this damage as the padding softens the impact of the dummy's head during rebound.

The addition of the ATDHPD does not affect the performance of the CRS while in frontal loading and may prevent or minimize unnecessary damage to a dummy's head. Testing of two belt-positioning seats with and without the ATDHPD showed that results were comparable and achieved acceptable repeatability (see Table 4 and Table 5).

While one of the belt-positioning seats tested was a high back model, NHTSA is only specifying the optional use of the ATDHPD when using backless belt-positioning seats. This is because the head impacts were occurring with backless belt-positioning seats, as there was no back on the CRS to prevent the rebound head motion. Also, while test data show there was no difference in testing with and without the ATDHPD, NHTSA would like more data to verify that all high back belt-positioning seats would be unaffected by the ATDHPD. Therefore, NHTSA is only specifying the optional use of the ATDHPD for backless belt-positioning seats due to the high potential for damage to the dummies when testing these types of child restraint systems.

Table 4. Test Results of Cosco Pronto With and Without ATDHPD

¹⁰² The ATDHPD resembles a head restraint, but it was not designed to be representative of one.

| Cosco Pronto - HIII-6YO – Belt-Positioning Seat | | | | | |
|--|-----------------|--------------|---------------------------------------|------------------------------------|------------------------------------|
| Test Number | | HIC36 | Chest Acceleration (g) | Head Excursion (mm) | Knee Excursion (mm) |
| RR05-19-13 | | 650 | 58.7 | 528 | 613 |
| RR05-19-14 | | 621 | 51.9 | 525 | 605 |
| RR05-19-15 | | 663 | 52.5 | 533 | 613 |
| Calspan Without ATDHPD | St. Dev. | 21.6 | 3.8 | 4.3 | 4.3 |
| | Average | 645.1 | 54.4 | 528.7 | 610.1 |
| | CV | 3.4 | 7.0 | 0.8 | 0.7 |
| RR06-20-32 * | | 582 | 50.2 | 537 | 610 |
| RR06-20-33 * | | 575 | 53.7 | 539 | 612 |
| RR06-20-34 * | | 511 | 51.5 | 538 | 607 |
| Calspan * ATDHPD | St. Dev. | 39.5 | 1.8 | 1.3 | 2.3 |
| | Average | 556.1 | 51.8 | 538.1 | 609.6 |
| | CV | 7.1 | 3.5 | 0.2 | 0.4 |
| All | St. Dev. | 56.4 | 3.0 | 5.9 | 3.1 |
| | Average | 600.6 | 53.1 | 533.4 | 609.8 |
| | CV | 9.4 | 5.7 | 1.1 | 0.5 |

Table 5. Test Results of Chicco GoFit With and Without ATDHPD

| Chicco GoFit NB - HIII-10YO – Belt-Positioning Seat | | | | |
|--|--------------|---------------------------------------|------------------------------------|--------------------------------|
| Test Number | HIC36 | Chest Acceleration (g) | Head Excursion (mm) | Knee Excursion (mm) |

| | | | | | |
|---------------------|-----------------|-----|------|-------|-------|
| RR06-19-40 | | n/a | 47.5 | 502 | 676 |
| RR06-20-26 | | n/a | 45.5 | 496 | 662 |
| Calspan | St. Dev. | n/a | n/a | n/a | n/a |
| Without | Average | n/a | n/a | n/a | n/a |
| ATDHPD | CV | n/a | n/a | n/a | n/a |
| RR02-20-24 * | | n/a | 47.2 | 514 | 685 |
| RR02-20-25 * | | n/a | 44.9 | 498 | 671 |
| RR06-20-40 * | | n/a | 48.2 | 485 | 682 |
| Calspan * ATDHPD | St. Dev. | n/a | 1.7 | 14.2 | 7.0 |
| | Average | n/a | 46.8 | 498.9 | 679.4 |
| | CV | n/a | 3.6 | 2.8 | 1.0 |
| All | St. Dev. | n/a | 1.4 | 10.2 | 8.9 |
| | Average | n/a | 46.7 | 498.9 | 675.3 |
| | CV | n/a | 3.0 | 2.0 | 1.3 |

2. Truncating Head Acceleration Time Histories

In the NPRM, NHTSA requested comment on whether, in a compliance test, NHTSA should compute HIC36 for backless belt positioning seats tested with the HIII-6YO dummy using an acceleration pulse that is truncated to 175 msec.¹⁰³ The seat back of the proposed standard seat assembly was raised from an earlier version to reduce dummy head contact with the rear seat structure of the proposed standard seat assembly. While raising the seat back reduced the number of head contacts with the rear seat structure, NHTSA observed that head contact still occurs when testing backless belt-positioning seats with the HIII-6YO dummy. In conducting research tests to inform the revisions to these tests, the agency made the HIC36

¹⁰³ 85 FR at 69424, col. 1.

calculation using a head acceleration pulse truncated between 175-200 msec, which corresponded to a time in the rebound phase before the head impact with the seat support structure.

Comments Received and Agency Response

Consumer Reports supported truncating the data set at 175 msec. No commenter opposed this truncation. NHTSA will incorporate a 175 msec data truncation to exclude rebound high head accelerations from HIC36 calculations. The accommodation will only be made for backless booster seats tested with the HIII-6YO dummy and not for all CRSs because this configuration sometimes results in head acceleration spikes when the dummy is rebounding into the updated standard seat assembly after the simulated crash. Because the HIII-6YO seated in a backless booster seat typically has a height higher than the seat back of the updated standard seat assembly, the dummy's head hits the updated standard seat assembly's metal frame causing the head acceleration spike.¹⁰⁴ NHTSA does not see the need to apply this truncation to other dummies and/or other CRS types as a smaller dummy's head does not reach past the top of the seat back¹⁰⁵ and other types of CRSs typically have a seat back of their own with structure and padding protecting the head of the dummy, both of which prevent high HIC spikes against the seat back. Moreover, NHTSA believes it is not in the interest of safety to truncate HIC values in tests other than of backless booster seats tested with the HIII-6YO dummy. If HIC values exceeded the standard's limit were measured for any other type of CRS, or for backless boosters using any other type of dummy, NHTSA would investigate those test results as a noncompliance because they are indicative of a potential safety concern.

3. Drawing Changes

Graco identified potential errors in some of the drawings of the proposed standard seat assembly¹⁰⁶ or places where ambiguity exists and suggested corrections or improvement. The

¹⁰⁴ These high HIC accelerations are also present when using the optional ATD Head Protection Device, therefore, HIC truncation is still relevant for the HIII-6YO in backless booster seats.

¹⁰⁵ The HIII-10YO dummy does not measure HIC, therefore, the truncation is not an issue.

¹⁰⁶ May 2019 Child Frontal Impact Sled Drawing Package (NHTSA-213-2016)

commenter also suggested improvements to the drawings to address variability. NHTSA discusses these comments below.

Dimension Discrepancy

Graco notes there are multiple dimension call outs for the shoulder belt anchor hole and requests NHTSA clarify which dimension takes priority. The location is identified in the drawing package four times, and three different vertical dimensions provided:

- 953 ±3 mm (3021-010, Sheet 1), using part 3021-209 as the reference plane
- 953 ±3 mm (3021-015, Sheet 1), using part 3021-209 as the reference plane
- 941 ±3 mm (3021-015, Sheet 2), using part 3021-200-9 as the reference plane
- 877 ±6 mm (3021-1000, Sheet 1), using part 3021-200-9 as the reference plane

In response, NHTSA believes that no changes to these drawings are necessary. Drawings 3021-010&3021-0015-Sht1 reference the bottom of the buck and include attachment plate (12.5mm/0.50") foot; 3021-0015-Sht2 is referenced to the bottom of the 4-inch tube; and 3021-1000 is referenced to the bottom of the 2-inch tube. Due to the different reference points these dimensions need to be different.

Dimension Conflict

Graco notes that drawing 3021-209 has a conflict between the plate thickness in the material note (thickness given as 12.5 mm) versus the dimension on the face of the drawing (12.7 mm). It believes the intent is to use standard gauge plate as suggested by the 0.5 inch for thickness referred to in the materials note, which would make the correct value 12.7 mm. It requests that NHTSA reconcile the two dimensions.

In response, NHTSA has reconciled the dimension to 0.5 inch so that drawings are consistent.

Missing Dimension

Graco comments on a dimension that may be missing for a seat back support tube. On drawing 3021-015, Sheet 2, Revision D, section B-B, a vertical dimension is called out for the

second support tube, however, Graco notes that there is a dimension missing for the third support tube. Graco suggests that a dimension be given for this third tube to ensure a consistent standard seat assembly.

In response, NHTSA has added dimensions for the seat tube as suggested.

Notes

Graco requests notes clarifying the manufacturing intent when it comes to several hole features. For reference, Graco states it appreciates Note 1 of drawing 3021-265, Revision D, that calls for mounting holes to be drilled after standard seat assembly. The note communicates to standard seat assembly manufacturers that if the holes were drilled into the individual parts before assembly, the resulting tolerance stack up might place the holes in locations that preclude the standard seat assembly from being used as intended. Graco requests notes on the following:

- 3021-255, Sheet 1: Seat Frame Gusset Plate
- 3021-326, Sheet 1: D-Ring Anchor
- 3021-756, Sheet 1: Latch Belt Anchor Plate

Alternatively, Graco requests NHTSA omit the note from 3021-265. Graco explains that because of the presence of Note 1 on 3021-265, and its omission on the drawings for the three parts listed, there may be some ambiguity as to whether these holes should be drilled and/or tapped before or after assembly.

NHTSA is not making the suggested change. Each of the anchor assemblies and pieces already have tolerances in each of the drawings. It is up to the fabricator to determine whether to drill the hole prior to welding or after. The final assembly drawing 3021-1000 is to be used to verify the anchors are within specifications.

Tolerances of Z-point

Drawing 3021-015, Sheet 1, Revision D, lists the horizontal and vertical dimensions for the Z-point as 120 mm and 80 mm, respectively, referencing the lowest, rearmost seat tubes. The tolerance per Note 1 on 3021-015 is ± 3 mm. The Z-point dimensions are called out on

drawing 3021-1000, Sheet 1, Revision A. However, the tolerance for this Z-point is specified in Note 1 as ± 6 mm. Graco states that if seat assembly manufacturers choose to use drawing 3021-1000 as their reference, there is a possibility that two standard seat assemblies made by different manufacturers could have Z-points off by as much as 12 mm vertically or horizontally. Graco believes that this maximum error difference of 12 mm versus 6 mm can have significant consequences in lab-to-lab correlation scenarios. Graco requests that a single tolerance value be harmonized across all drawings that are used to locate the Z-point.

In response, NHTSA has revised Drawing 3021-1000 to note ± 3 mm for the Z-point dimension.

Materials Specifications

Graco requests the most recently published material standards from AISI, ASTM, SAE, to be specified on each drawing. It notes that none of the materials are specified beyond “steel” or “steel, mild” other than the bold text in drawing 3021-332.

In response, NHTSA has changed the drawings so that steel is called out by ASTM number. Drawing 3031-332 in the NPRM drawing package has been removed but NHTSA added specific requirements on the detailed assembly drawings with the correct type of steel, aluminum, etc.

Foam Cushion Drawings Density Specifications References

Graco comments that drawings 3021-233 Seat Pan Cushion and 3021-248 Seat Back Cushion refer to “NHTSA Specifications on Preliminary Bench” in the Procurement Specifications and Test Certification Specifications blocks (four references total). The commenters request that these specifications be updated to indicate that they apply to the representative test standard seat assembly specified in the NPRM.

In response, the agency has removed “preliminary” from the drawing package for this final rule.

Type 2 Cantilevered Anchorage Beam

Graco identified a structural issue with the Rear Shelf Mount, drawing 3021-850, that affects durability of the proposed standard seat assembly and potentially the repeatability and reproducibility of test results over time. Graco explains that the Rear Shelf Mount spans the width of the proposed standard seat assembly structure and serves to tie the Rear Locking Belt Mounting Bar Assembly (3021-333) to the structure, as shown in the detail from the standard seat assembly schematic drawing in the figure below.

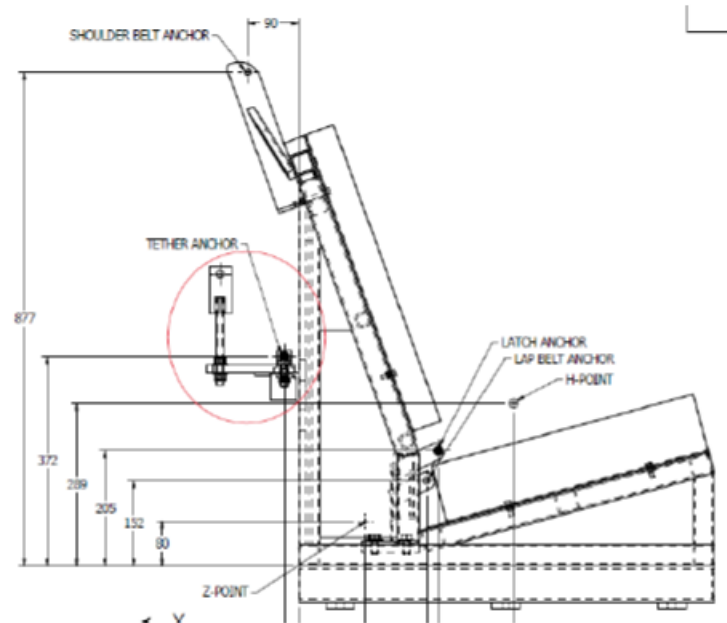

Figure 3. Detail from Drawing 3021-1000 Bench Seat Schematic Showing Tether Anchor Mounting (Circled) (Figure provided by Graco).

Graco notes that this item is made from 3/16-inch-thick extruded steel angles with the material specified as “mild steel.” It states that it observed upward flexing of this part when testing with all the child dummies, and it is most pronounced when testing with the HIII-6YO and the HIII-10YO dummies. The commenter provides an illustration of this in a still image in its comment showing the Rear Locking Belt Mounting Bar Assembly (marked before the test with yellow tape as seen in the image) bending approximately 15 degrees from its normal horizontal orientation during the dynamic test. Graco notes that the moment arm created by the belt anchor location acting upon the Rear Shelf Mount is causing the Rear Shelf Mount to deform where the two parts are joined.

Graco found that the Rear Shelf Mount was permanently deformed to 5.7 degrees from the horizontal. It expresses concern that this part of the structure is too thin and will eventually crack or tear. The commenter suggests making the steel angle thicker (1/4" – 3/8"), using a higher strength grade of steel, providing additional local reinforcement, and/or providing additional components in order to rigidize the connection point for the Rear Locking Belt Mounting Bar Assembly.

To assess the potential impact of the deformation on injury criteria, Graco states it secured the Rear Locking Belt Anchor to the main structure of the proposed standard seat assembly with a ratchet strap to prevent some movement. The commenter assessed the relative difference in motion of the Rear Locking Belt Mounting Bar Assembly during a dynamic test with and without the ratchet strap. Graco states it saw similar excursion values, similar or slightly increased chest resultant values, and an overall decrease in HIC36 values. The commenter expresses concern that this deformation is likely to “creep” over time, requiring maintenance cycles. It suggests some child restraint systems may be more sensitive to the effects of bending of the Rear Shelf Mount during testing.

In response, NHTSA has revised the drawings to update the anchor beam to have a 3/8-inch thickness instead of a 3/16-inch thickness. NHTSA’s experience with testing with an anchor beam with a 3/8-inch thickness found no deformation. Strengthening the anchor beam addresses Graco’s comment.

Shoulder Belt D-Ring and Inboard Type 1 (Lap Belt) Anchor

Graco states that the shoulder belt D-ring (drawing 3021-123) and the inboard Type 1 (lap belt) anchor (drawing 3021-120) are deforming during testing. Graco explains that this deformation was observed after only two or three tests with the HIII-6YO dummy. The commenter is concerned that over time, one of these anchor points could fail during a test. The commenter believes this deformation also calls into question “the repeatability and reproducibility of tests using undeformed and deformed anchors.” Graco recommends making

the D-ring and inboard anchor out of a harder type of steel and/or increase their dimensions in the direction of loading to prevent them from bending under dynamic forces.

In response, NHTSA will not change the materials of the D-Ring and inboard anchor. These are parts that are meant to be replaced and NHTSA will provide a pass/fail gauge in the test procedure that can be used to evaluate when it is necessary to change them. Drawings for the pass/fail gauges will be available in the drawing package. The Compliance Test Procedure will include procedures to check the sled with the gauges.

Sharp Edge in the Tether Strap Routing Path

Graco provided an image showing how the child restraint tether passes over the top cross bar structure of the proposed standard seat assembly. It notes that the sharp edge is caused by the Bench Seat Back Plate (part number 3021-265) where the tether webbing makes contact, potentially resulting in the webbing tearing. The commenter believes that this risk may be greater if the proposed standard seat assembly design is used for side impact testing. Graco recommends that the upper edge of the Bench Seat Back Plate be rounded off with a radius of at least half the thickness of the plate stock or lowered slightly from the top plane of the proposed standard seat assembly such that it does not contact the webbing during testing, as it does not represent real vehicle seating compartments.

In response, NHTSA agrees with the suggestion and has updated the drawings (for the frontal and side standard seat assemblies) to round the sharp edge on the seat back plate to prevent tether tearing.¹⁰⁷

f. Why NHTSA Has Not Adopted a Floor (Reiteration)

In the NPRM, NHTSA denied a petition for rulemaking from Volvo to add a floor to FMVSS No. 213's sled fixture used in the compliance test.¹⁰⁸ Several commenters to the NPRM asked the agency to reconsider the petition denial. NHTSA does not have a mechanism

¹⁰⁷ NHTSA revised the side impact drawings prior to the June 30, 2022 final rule to include these changes in FMVSS No. 213a.

¹⁰⁸ 85 FR at 69402.

recognizing requests to reconsider petition denials other than considering them as regular correspondence to the agency. The agency is under no legal obligation to respond to the NPRM comments requesting NHTSA to reconsider the petition. However, since many were interested in adding a floor to FMVSS No. 213's standard seat assembly, the agency responds to the comments in the discussion below.

JPMA, Evenflo, and Consumer Reports believe that a standardized floor for the test sled would help ensure testing consistency of support legs in all test labs. Additionally, SRN, Evenflo, and Volvo believe a standardized floor would benefit testing of support legs. Evenflo suggests that NHTSA create a separate compliance standard for testing CRSs that feature a support leg. Volvo states that a standardized floor is part of many European testing provisions for CRSs and believes a floor is needed as part of the standard seat assembly to enable the use of a support leg. Volvo believes that by including a floor in the standard seat assembly “and thereby enabling the use of a support leg, the CRS can be made more comfortable, attractive and safer for children.”

Agency Response

As noted above, NHTSA will not be including a standardized floor as part of the test sled in this final rule. In this section, we acknowledge the comments expressing interest in a floor and highlight the following points reiterating our views in denying the petition for rulemaking.

NHTSA wishes to emphasize at the outset that the Federal motor vehicle safety standards set minimum safety standards. In other words, FMVSS No. 213 sets a minimum threshold that all CRSs must pass to meet the need for safety and does not set an upper limit for performance. FMVSS No. 213 does not prohibit manufacturers from designing CRSs to have support legs as long as the child restraint system can be certified as meeting the standard without use of the support leg. Manufacturers currently offer CRSs for sale in the U.S. with support legs. The CRSs are more expensive than child restraints without legs, but they are available. These CRSs are required by FMVSS No. 213 to provide at least the minimum level of safety required by FMVSS

No. 213 when the leg is not used. If a CRS cannot meet the requirements of the standard without the support leg, FMVSS No. 213 prevents its sale in the U.S.

This is because FMVSS No. 213 standardizes the means of attaching the CRS to the vehicle to increase the likelihood of correct installation of the child restraint. Under the standard's approach, a caregiver does not need to learn novel ways of installing a child restraint each time a new CRS is used, or each time a CRS is used in a different vehicle, to ensure their child is protected by the restraint. Standardization also ensures that the high level of protection provided by FMVSS No. 213 will be provided by each CRS installed in every vehicle simply by use of the seat belt or child restraint anchorage system lower attachments, with or without a tether. NHTSA does not know if caregivers will correctly use a support leg. Misuse and nonattachment of tethers is a problem now. Requiring an additional mechanism, the caregiver must properly manipulate for the CRS to be properly installed only risks increasing the rates of misuse. If a CRS is unable to provide at least the minimum level of safety required by the standard without the support leg, then it would be detrimental to safety to allow a leg if the leg may not be used.

If the commenters' support for a floor is based on the premise that NHTSA would also permit the leg to be used as a means to comply with FMVSS, our answer is we would not permit such use, based on the state of current knowledge. Given possible misuse of support legs, NHTSA is not convinced it would be appropriate to permit support legs to be used to meet FMVSS No. 213. Data indicate that misuse of CRSs is high, e.g., tethers are not widely used despite how beneficial they are to safety. We also do not know enough about unintended consequences to the child occupant or other occupants seated nearby resulting from non-use of a leg on the CRS.

NHTSA is concerned that providing a support leg could significantly increase the average price of CRSs. NHTSA must balance any benefits accruing from use of a support leg with the cost of the CRSs, as well as the effect on the ease-of-use of the restraint. CRSs currently on the

market that include a support leg are generally more expensive than CRSs without support legs. Requiring a support leg could make an already expensive safety device more expensive and price some caregivers out of the new CRS market.

We also strongly oppose, on principle, having FMVSS No. 213 apply to some child restraints and another FMVSS with enhanced requirements apply to other child restraints (that are likely at higher price points). Such a system could be creating a “have” and “have not” ranking system that would essentially deem some child restraints safer than others and some children more protected than others. Such an approach would be confusing and unhelpful to consumers and, on its face, unfair. The agency has devised minimum safety requirements that are applied to all child restraints, so caregivers can be assured all child restraints provide *at least* the same minimum level of protection that NHTSA has deemed requisite to meet the need for motor vehicle safety.

For the reasons described above, the agency is not devoting its limited research and rulemaking resources on developing a floor for the standard seat assembly.

VII. Retaining the Type 1 (Lap Belt) Installation Requirement

a. CRSs for Use in Older Vehicles

As noted above, there was widespread support for the proposal that CRSs must be capable of being anchored to the standard seat assembly by way of Type 2 belts and meet FMVSS No. 213 when attached with the belts. However, SBS and SRN strongly oppose removing the requirement to comply when tested with the Type 1 belt. These commenters believe it is premature to remove the Type 1 belts test in FMVSS No. 213 as there are still many vehicles in the vehicle fleet with Type 1 belts. The commenters add that it is usually families with limited incomes that use older vehicles to transport children. SBS states that “41 percent of U.S. children live in low-income families. These children are more likely to be transported in older vehicles and are known to be at greater risk of injury in traffic collisions.” SBS and SRN

urge NHTSA to retain the Type 1 belt test, at least for a while longer, to meet the needs of persons who may own vehicles that do not have Type 2 belts in rear seats.

SBS and SRN believe that there are differences in performance using a Type 1 versus a Type 2 belt, and that testing with a Type 1 belt results in more safety benefits than testing with a Type 2, i.e., a Type 1 test presents more demanding conditions on the CRS than a test with a Type 2 belt. SRN argues that the data NHTSA presented to demonstrate that Type 2 provides the same, if not increased, safety was insufficient. The commenters believe that a Type 2 belt may mitigate the effects from lack of tether use by providing additional restraint to the upper part of the child restraint, but that the tether anchor point is not present in vehicle installations using only a Type 1 belt. SRN argues that this creates a testing scenario that is not representative of real-world installations of many children who ride untethered in child seats secured with Type 1 belts in older model vehicles.

SBS and SRN are also concerned that CRS manufacturers might strongly warn consumers against Type 1 installation with their products because FMVSS No. 213 will no longer specify testing of them with Type 1 seat belts. The commenters state that this would not only reduce the availability of CRS to persons needing CRSs designed for attachment by Type 1 seat belts, but also compel families with vehicles made before MY 1989 to place CRSs in the front seat where there is a Type 2 belt.

SRN also believes that most CRSs will not be tested with the child restraint anchorage system because with the appropriate test dummy, they weigh 65 lb or more. (FMVSS No. 213 specifies that child restraints must instruct owners not to use the lower anchors of the child restraint anchorage system when the combined weight of the CRS and the child is over 65 lb, to avoid overloading the lower anchors.) Accordingly, a seat belt will be the primary means of attaching these child restraints. SRN believes that child restraints should be assessed in FMVSS No. 213 with a Type 1 seat belt as Type 1 seat belts will be used to attach a child restraint in older model vehicles.

SRN also expresses concern about limitations that would be placed on conventional CRSs used on school buses, where Type 1 belts are more common than Type 2 belts, even in many newer buses. NHTSA notes that IMMI and the Salem-Keizer Public Schools also comment on this issue, but their views were supportive of the switch to certification using the Type 2 belt.¹⁰⁹ IMMI notes that some current pre-K transportation programs, including Head Start programs, still choose to use passenger vehicle CRSs in their school buses. IMMI states that in the case of children under the age of two, passenger vehicle rear-facing infant seats must be used as there are no school bus-specific CRS alternatives and that many current school buses used for pre-K transportation will only have Type 1 belts for the attachment of these CRSs rather than Type 2 belts. However, IMMI does not believe that this consideration should prevent adoption of the proposal. Salem-Keizer Public Schools states that in Oregon, it is prohibited from purchasing a school bus with Type 1 belts, only a bus equipped with a Type 2 seat belt assembly is allowed. The commenter also states that it is beginning to transition to a full fleet of school buses equipped with Type 2 belts. In support of removing the Type 1 belt testing, Salem-Keizer Public Schools states: “While [transitioning to a full Type 2 fleet] will take time, updating the crash test standards will ensure that CRSs used in school buses have been tested using systems available to use in both school buses and [multipurpose passenger vehicles].”

Agency Response

NHTSA appreciates the comments on this issue. After reviewing the comments, we agree with SBS and SRN to retain the requirement to certify certain CRS when installed solely with a Type 1 belt, for a limited time for the reasons provided below. We will retain the requirement until September 1, 2029, to allow time for the on-road vehicle fleet to change over to where an

¹⁰⁹ Under FMVSS No. 222, “School bus passenger seating and crash protection,” school buses with a gross vehicle weight rating (GVWR) of over 4,536 kg (10,000 lb) (large school buses) are not required to have passenger seat belts. If a manufacturer voluntarily installs passenger seat belts, it may be a Type 1 or Type 2 belt, although NHTSA recommends Type 2 belts if a decision-maker had to choose between the two. School buses with a GVWR up to 4,536 kg (10,000 lb) (small school buses) are required to have Type 2 belts.

estimated 90 percent of passenger vehicles will have Type 2 belts in rear seating positions. Our basis for the date estimate is explained later in this section.

NHTSA agrees with SRN and SBS's concerns regarding the availability of CRSs that can be installed with Type 1 belts to persons with older vehicles. We estimate that about 36 percent of the 2022 light duty vehicle fleet are of model years (MY) 2000-2007 that do not have Type 2 belts in all rear seating positions.¹¹⁰ NHTSA concurs that 36 percent is too high a value to begin allowing CRSs to be designed only for vehicles with Type 2 belts in all rear seats. Some people driving MY 2006-2007 vehicles may not have the economic means to purchase a newer vehicle with Type 2 belts in all rear seats. This decision to retain the Type 1 test advances equity in vehicle safety by ensuring that children are equally protected by child restraints no matter the economic status of their caregiver or the age of the vehicle they are riding in. This decision accords with the Safety Act and the principles of E.O. 13985, "Advancing Racial Equity and Support for Underserved Communities Through the Federal Government."¹¹¹

NHTSA's intent in the NPRM for testing CRSs with Type 2 belt installation and removing the Type 1 belt test was to encourage future CRS designs that take advantage of the shoulder belt portion of the seat belt to reduce excursions. We also sought to reduce unnecessary test burdens. However, we recognize the possibility of CRS manufacturers restricting the installation of their CRSs with Type 1 belts. While Standard 213 would not prohibit CRS manufacturers from voluntarily instructing owners they may use the CRS with a Type 1 belt, we have seen that typically manufacturers do not recommend any installation that is not in FMVSS No. 213, other than Type 2 belt installations which are not yet required in FMVSS for non-booster CRSs. For example, CRS manufacturers typically prohibit the use of CRSs in a non-forward-facing vehicle seating position, even though CRSs are highly effective in the field when subjected to crashes in all directions (which mimic the accelerations of a non-forward-facing

¹¹⁰ Vehicle registration data for passenger vehicles (cars and light trucks) were obtained from R.L. Polk's National Vehicle Population Profile (NVPP), which is a compilation of all passenger vehicles that have been registered in compliance with State requirements. (R.L. Polk is a foundation of IHS Markit automotive solutions.)

¹¹¹ January 20, 2021.

seating position). The agency believes that CRS manufacturers prohibit this orientation because their CRSs are not tested in that manner in the FMVSS No. 213 sled test protocol. NHTSA is retaining the Type 1 belt provisions to assure the continued wide availability of CRSs to caregivers with vehicles with only Type 1 belts in rear seats.

Retaining the requirement for CRS to be certified as meeting FMVSS No. 213 when anchored by the Type 1 seat belt best assures CRSs anchored with Type 1 seat belts will continue to meet FMVSS No. 213. In current CRS designs, the lap belt portion of the Type 1 and Type 2 belt installation follow the same routing path and the shoulder belt portion has minimal interaction, so sled test results with Type 1 belt and Type 2 belt installation are similar. Even though there were only a few test comparisons in the NPRM, we see this design commonality among CRS designs and expect similar performance in installations using Type 1 and Type 2 belts as the shoulder portion of the Type 2 belt has little interaction with the CRS during the test and does not, for example, hold down the top of the CRS back. However, future designs could change and the shoulder portion of the Type 2 belt could be routed in a different manner on a particular child restraint. NHTSA is retaining the Type 1 belt provisions to ensure that a CRS anchored with a Type 1 belt will meet the standard's requirements just as it will have to meet the standard when anchored with a Type 2 belt.

SBS suggests that, to reduce compliance costs, the standard could provide that if a child seat meets the requirements with a Type 1 belt, it will not be tested with a Type 2 belt. NHTSA has decided not to adopt that approach. If future child seat designs change and Type 1 and Type 2 belts are no longer routed the same way through the child seat, subjecting CRSs to testing with both the Type 1 and Type 2 belts assures the child restraint will meet the standard when anchored using either belt type.

Lastly, retaining the requirement to certify CRS with the Type 1 seat belt until 2029 provides time for pupil transportation programs to use current child restraints on vehicles that only have Type 1 belts. And from now until 2029, we anticipate that manufacturers will be able

to develop “school bus child restraint systems,” permitted by this final rule, which are CRSs that are designed for exclusive use on school bus seats. As a result of this rule, specially designed CRSs will be able to step in when the lap-belt attachable child restraints are no longer required to be made. We also believe that, between now and September 1, 2029, more school buses will be equipped with Type 2 belts compared to Type 1 belts. This is because FMVSS No. 208 requires Type 2 belts on small school buses rather than the formerly required Type 1 belts, and because increasing numbers of schools are ordering large school buses with Type 2 belts rather than Type 1 belts when they seek to have passenger seat belts on the vehicles.

Basis for the 90 Percent Estimate

Child restraint systems will be subject to the requirement to meet FMVSS No. 213 with a Type 1 belt until September 1, 2029, to allow time for the on-road vehicle fleet to change to a fleet with Type 2 belts in rear seats.¹¹² In 2004, NHTSA issued a final rule requiring all light vehicles to be equipped with Type 2 belts in all designated rear seating positions by September of 2007.¹¹³ Data indicate that 36 percent of the 2022 light duty vehicle fleet are from model years 2000-2007¹¹⁴ and may not have Type 2 belts in all rear seating positions. The same data indicate that by 2029, 90 percent of the light duty vehicle fleet will be vehicle model year 2008 and later, meaning that 90-plus percent of vehicles in the light duty vehicle fleet will be equipped with Type 2 belts in all rear seating positions from 2029 onward.

NHTSA agrees with SRN and SBS’s concerns regarding the availability of CRSs that can be installed with Type 1 belts to persons with older vehicles. We are mindful that a portion of vehicles in the vehicle fleet will only have Type 1 belts in some rear seating positions. We also know that this portion of vehicles will decrease every year. With the decreasing availability of

¹¹² As explained in the next section, child harnesses will be tested indefinitely with the Type 1 belt.

¹¹³ NHTSA issued a final rule on December 8, 2004 requiring all vehicles with a GVWR less than 10,000 pounds (light duty vehicles) to be equipped with Type 2 belts in all designated rear seating positions by September 1, 2007. The requirements were phased in. 69 FR 70904.

¹¹⁴ *Vehicle registration data for passenger vehicles (cars and light trucks) were obtained from R.L. Polk’s National Vehicle Population Profile (NVPP), which is a compilation of all passenger vehicles that have been registered in compliance with State requirements. (R.L. Polk is a foundation of IHS Markit automotive solutions.)*

Type 1 belts in the fleet, the need to require CRSs to meet Type 1 belt requirements lessens with time.

Using the 2022 vehicle fleet data set, we can look at the cumulative percentage of vehicles of a specific model year or newer (see Table 6). Data shows that 91 percent of all light duty vehicles are MY 1999 or newer, 95.3 percent are MY 1994 or newer and 97 percent are MY 1989 or newer. Assuming the fleet continues aging in a similar manner¹¹⁵ we can estimate that 90 percent of the light duty vehicles will be MY 2008 or newer in 2029, 95 percent of them in 2034 and 97 percent of them in 2039 (see Table 7).

Table 6. Percentage of Vehicles in the 2022 Vehicle Fleet by Range of Vehicle Model Years

| Percentage of MY Range | | | |
|-------------------------------|-------------|-------------|-----------------|
| MY Range | Cars | LTVs | All LDVs |
| 1984-2022 | 97.1% | 98.7% | 98.1% |
| 1985-2022 | 96.9% | 98.6% | 97.9% |
| 1986-2022 | 96.7% | 98.4% | 97.7% |
| 1987-2022 | 96.4% | 98.2% | 97.5% |
| 1988-2022 | 96.2% | 98.0% | 97.3% |
| 1989-2022 | 95.9% | 97.7% | 97.0% |
| 1990-2022 | 95.6% | 97.4% | 96.7% |
| 1991-2022 | 95.4% | 97.1% | 96.4% |
| 1992-2022 | 95.1% | 96.8% | 96.1% |
| 1993-2022 | 94.7% | 96.5% | 95.8% |
| 1994-2022 | 94.3% | 96.0% | 95.3% |
| 1995-2022 | 93.9% | 95.3% | 94.8% |
| 1996-2022 | 93.3% | 94.5% | 94.0% |
| 1997-2022 | 92.6% | 93.7% | 93.3% |
| 1998-2022 | 91.7% | 92.5% | 92.2% |
| 1999-2022 | 90.5% | 91.3% | 91.0% |
| 2000-2022 | 89.1% | 89.5% | 89.4% |

Table 7. Projected Years for MY 2008 or Newer Share

| Projected Year for MY 2008+ Share | | | |
|--|-------------|-------------|-----------------|
| Share | Cars | LTVs | All LDVs |
| 90% | 2029 | 2029 | 2029 |
| 95% | 2036 | 2033 | 2034 |
| 97% | 2044 | 2037 | 2039 |

¹¹⁵ The pandemic slowed down sales due to supply chain issues.

We agree that eliminating the Type 1 installation tests when 36 percent of the vehicle fleet is older than 2008 MY vehicles would be premature for the reasons discussed above. But Type 1 installation tests become less necessary for safety with the continued reduction of the share of older vehicles (older than 2008 MY) having Type 1 belts. The Type 1 tests may be preventing CRS manufacturers from designing lap-shoulder belt paths that may function as a tether. This pseudo-tether would reduce a child's head excursions, reducing injury severities and lowering the fatality risk for a larger portion of the market.

Accordingly, after balancing the above considerations, NHTSA will proceed with eliminating the Type 1 installation provisions but delay the effective date until September 1, 2029. This will give enough time for 90 percent of the vehicle fleet to be comprised of vehicles MY 2008 or newer. Thus, CRS manufacturers will continue to produce CRSs capable of Type 1 installations to families with older vehicles that have Type 1 belts in rear seating positions.

The agency will also sunset the requirement of providing a diagram with the child restraint system installed with lap belt (S5.5.2(1)(2)) as it will no longer be a requirement, but we note that manufacturers can voluntarily provide such diagram after the requirement sunsets.

b. Installing Harnesses

A "harness" is a type of child restraint system. (When we refer to a "harness" in this section (b), we mean a harness that is not exclusively produced for school bus use.) "Harness" is defined in FMVSS No. 213 as "a combination pelvic and upper torso child restraint system that consists primarily of flexible material, such as straps, webbing or similar material, and that does not include a rigid seating structure for the child" (S4). The child wears the harness like a vest and typically sits directly on the vehicle seat wearing the harness. A harness does not boost the child. A harness is not a booster seat.

Currently under FMVSS No. 213, a harness is attached to the standard seat assembly in a compliance test by way of the Type 1 belt and a tether. It makes sense that harnesses are attached with a Type 1 belt, as the purpose of a harness is to restrain a child's upper body in the absence

of a shoulder belt,¹¹⁶ i.e., when there is only a Type 1 belt in the vehicle. The November 2, 2020 NPRM proposed replacing the Type 1 seat belts on the standard seat assembly with Type 2 seat belts. Under the regulatory text of the NPRM, harnesses would have been attached to the standard seat assembly by the Type 2 seat belt because only Type 2 belts would be on the standard seat assembly.

As explained above, after considering SRN and SBS's comments, NHTSA has decided in this final rule that the Type 2 seat belt on the standard seat assembly should not fully replace the Type 1 belt. There is a safety need to be able to assess the performance of child restraints made for Type 1 belts. NHTSA has made a similar determination relative to harnesses. Harnesses are designed for use with a Type 1 belt. A harness provides upper body restraint to children when only a Type 1 seat belt is present. Harnesses should continue to be tested with the Type 1 belt on the standard seat assembly to assess their performance when installed with Type 1 seat belt, *viz.*, to assess their ability to provide upper body restraint. For such an assessment to be true, the influence of the shoulder belt should be excluded from the test.

Thus, not only is testing harnesses with a Type 1 belt reflective of their intended use, testing harnesses with a Type 2 belt would be troublesome. FMVSS No. 213 does not allow harnesses to be tested with the Type 2 belt that is currently on the standard seat assembly because it does not make sense to do so. A Type 2 belt is simply a lap/shoulder belt, and if a lap/shoulder belt were routed in front of a child, like with an adult, the harness is not functioning as a child restraint system.¹¹⁷ Devices designed to simply route a Type 2 belt are not "child restraint systems" because they do not restrain, seat, or position children in a motor vehicle.

For the above reasons, we have decided it does not make sense to change the status quo by testing harnesses with a Type 2 belt. The purpose of a harness is to provide upper body

¹¹⁶ It is the agency's understanding that in the past, the Type 1 belt was routed through a belt path that was sewn on the harness *behind* the child's back, but nowadays it appears many harnesses route the belt in front of the child.

¹¹⁷ Standard 213 defines a "child restraint system" as "any device, except Type 1 or Type 2 seat belts, designed for use in a motor vehicle or aircraft to restrain, seat, or position children who weigh 36 kilograms (kg) (80 [pounds]) or less."

restraint in a vehicle with only a Type 1 belt, so that is how harnesses should be tested. It would not be sensible to assess the devices with a Type 2 belt if the Type 2 belt is what is restraining the child occupant. Accordingly, this final rule specifies that harnesses will be tested with the Type 1 belt. The provision does not sunset in 2029.

NHTSA has been contemplating the role that harnesses should have in child passenger safety going forward. There have been so many child passenger safety achievements over the years, but harnesses seem to have been left behind. Among other things, NHTSA has required: Type 2 belts in rear seating positions for the betterment of children, a dedicated child restraint anchorage system, side curtain air bags that can benefit children who sit raised up on the vehicle seat, side impact protection requirements for child restraint systems, and labeling provisions geared to keep children in the highly protective confines of a child restraint system longer. Additionally, the agency is learning more about the effectiveness the measured seated height, i.e., boosting, may have for a child so they are better able to maintain an in-position posture in a crash. Yet, harnesses are excepted from or are unable to provide the advantages of these developments to a child occupant. NHTSA is interested in exploring what role, if any, harnesses should have in the modern era of child passenger safety.

VIII. Communicating with Today's Caregivers

a. The CRS Owner Registration Program

1. Background

This final rule amends FMVSS No. 213's (S5.8) CRS owner registration program and associated labeling requirements relating to the program. This final rule removes many of the standardization requirements for the information card portion of the registration form and provides additional options to reflect modern advances in communication technology, allowing manufacturers to better communicate with today's caregivers.

NHTSA created the CRS owner registration program in 1992 to improve the number of CRS owners responding to recalls from manufacturers.¹¹⁸ It is vital that CRS owners are made aware of CRS recalls so they can complete the recall process by having their CRS either remedied or replaced by the recalling manufacturer. The number of CRS owners who respond and complete the recall process with a recalling manufacturer contributes to NHTSA's calculation of the *recall completion rate*, and NHTSA is committed to improving that number. The agency believes that the adopted amendments discussed below will further that goal by giving manufacturers increased flexibility to communicate the importance of the CRS owner registration programs with their customers.

This final rule adopts virtually all the proposed changes to the CRS owner registration program described in the NPRM. Notably, this final rule removes restrictions on the messaging and design of the information portion of the card (the top part of the card above dashed line, as shown in Fig 9(a) of current FMVSS No. 213). In response to a comment, the final rule also gives CRS manufacturers the flexibility to include a QR code on the registration form to increase ease of registration for today's caregivers. Second, in response to a comment, this final rule requires that a space for a phone number be included on the "mail-in" portion of the card (the bottom part of the card below dashed line, as shown in Figure 9(a) of current FMVSS No. 213).

The purpose of the CRS owner registration program is to increase CRS recall completion rates, and that purpose has not changed since the program's inception in 1992. In the late 80s and early 90s, NHTSA believed that the recall completion rate could be increased by disseminating recall information directly to individual owners. Prior to the program, consumers were only indirectly notified of a safety recall by notice to the general public, such as postings at pediatricians' offices. Evidence at the time showed that CRS owners were eager to know if their CRS was recalled and were highly motivated to remedy their CRS if it had been recalled.¹¹⁹

¹¹⁸ Final rule, 57 FR 41428, September 10, 1992. NHTSA requires manufacturers to record and maintain records of persons registering as owners or purchasers of child restraint systems for a period of not less than six years from the date of manufacture of the CRS. 49 CFR part 588, "Child restraint systems recordkeeping requirements."

¹¹⁹ NPRM, February 19, 1991, 56 FR 6603, 6604

However, before the CRS owner registration program, there was only a 10 to 13 percent completion rate for CRS recalls. Given this paradox, NHTSA believed the recall rate was so low because owners were unaware that their CRS had been recalled. NHTSA adopted the CRS owner registration program to facilitate direct notification to owners in a recall campaign.

Since 1992, the average recall completion rate has increased from percentages in the low teens to 40 percent in recent years. Although this increase has moved the completion rate in the right direction, the agency seeks to increase the rate, especially considering that the CRS recall completion rate is low compared to the recall completion rate for vehicles, which was an average of 79 percent between 2006 and 2015. NHTSA believes the recall rate can be increased by increasing the CRS registration rate, which is currently around 23 percent. That 23 percent is particularly low considering the mail-in card includes paid postage and takes minimal effort to fill out.

The registration form consists of two parts.¹²⁰ The first part is the “information card,” which contains language on the importance of registering the CRS and instructions for how to register. The second part is the “mail-in card,” which is to be filled out, and mailed to the manufacturer, by the owner. On the mail-in card, manufacturers must preprint their return address and information identifying the model name or number of the CRS to which the form is attached, so that owners do not need to look up and provide that information themselves, as looking up the information could serve as an impediment to completing the registration process. The mail-in card must have distinct spaces for the owner to fill in their name and address and must use tint to highlight to the owner that minimal input is required to register. To distinguish the registration form from a warranty card that some caregivers choose to ignore, the requirements prohibit any other information from appearing on the registration form, except for identifying information that distinguishes a particular CRS from other systems of that model name or number.

¹²⁰ See Figures 9a and 9b of § 571.213 Standard No. 213; Child restraint systems.

In the 1992 final rule, NHTSA decided to make the registration form highly standardized.¹²¹ This was based off information the agency had gathered from a study of consumers' attitudes about the then-proposed program. Researchers found that participants—

[I]ndicated that they would be most likely to return a pre-addressed, postage-prepaid card with an uncluttered graphic design that clearly and succinctly communicates the benefits of recall registration, differentiates itself from a warranty registration card, and requires minimal time and effort on the participant's part.

NHTSA is encouraged that CRS recall completion rates have increased after the final rule, which is a clear indicator that the CRS owner registration program was an important step to improving recall remedy rates. However, given the advances in communication technologies and improved capabilities of manufacturers to communicate with their customers, the agency is confident the recall rate can be increased by way of the new technologies. NHTSA believes giving manufacturers more flexibility in their communication methods with customers will increase registration and recall completion rates. Thirty years have passed since the registration form requirements were finalized in the 1992 final rule. In that time, a generation of children has grown up to become the new caregivers of today. This new generation grew up with and continues to interact with rapidly changing advancements in electronic outreach, communication, and technology. NHTSA believes that the advantages gained from highly standardizing the mail-in form at the outset of the program in 1992 can be surpassed by the gains from giving manufacturers increased flexibility to communicate the importance of registering a CRS and in the means of registering, and will lead to increased registration rates. The agency also understands the importance of ensuring registering CRSs remains as straightforward and easy as possible, and we considered that important balance in issuing this final rule.

2. Comments to the NPRM and NHTSA's Responses

General

¹²¹ Final rule, *supra*, 57 FR at 41429, col. 2.

The agency received thirteen comments on the proposed amendments to the CRS owner registration program from private individuals, public entities, manufacturers, advocacy groups, hospitals, private companies, and research institutions. The overwhelming majority supported the relaxation of restrictions for the information card portion of the registration form. An overwhelming majority also supported the option of allowing manufacturers to include a QR code on the information card to improve ease of registration for many of today's caregivers.

Information Card

NHTSA proposed to remove the restrictions on size, font, color, layout, and attachment method of the information card portion of the CRS registration form. The agency also proposed that the wording on the information card would no longer be prescribed, giving CRS manufacturers leeway to use their own words to convey the importance of registering a CRS and instructions on how to register. The agency also proposed to apply these relaxed style and wording requirements to labels and printed instructions for proper use referencing the registration form.

As stated above, most commenters expressed strong support for the proposed design changes to the information card. However, SRN notes a concern that too much variability in the designs of the information card could render the registration form unrecognizable. The commenter believes that caregivers typically purchase multiple CRSs as their child grows so it would be a drawback if registration forms were not readily recognized as a registration forms. SRN also comments that NHTSA should not assume that all manufacturers will be equally thoughtful in their design of the information card, and that it is possible some manufacturers will use cluttered or difficult-to-read designs. The commenter recommends that NHTSA develop and supply standard pictograms that manufacturers can use on the information cards to limit the amount of artistic freedom manufacturers have. Additionally, SBS suggests that NHTSA encourage an industry-wide approach to design of the information cards to ensure consistency of messaging and to guard against conflicting messaging being established by manufacturers.

Agency Response

Although there is a non-zero risk some manufacturers may use designs or language for the information card that are difficult to read or understand, NHTSA believes that this risk is relatively small and is outweighed by the advantages that could be gained by increased design innovation. It is in a manufacturer's best interest to increase recall completion rates so that children are as protected as possible in their restraints, so it would not be logical for a manufacturer to intentionally design a cluttered registration form that is difficult to read. NHTSA believes there may be benefits to different designs in information cards, as standardized features may lose their efficacy over time. NHTSA adopted registration form requirements in 1992¹²² and updated the requirements to include paid postage in 2005.¹²³ In 2005, NHTSA reported a registration rate of 27 percent. Currently NHTSA estimates having a 23 percent registration rate. While there may be other factors for the registration rates decline, NHTSA believes the rigid design of the registration form could be a factor in the decline and a barrier to increase the registration rates. Because manufacturers have the resources and expertise to design their products to best appeal to their customers, a top-down approach established by NHTSA could be counterproductive to the benefits of varying designs and creative freedom. For the above reasons, NHTSA declines at this time to adopt SRN's recommendation that NHTSA put specific creative limitations on the information card.

Style and Language Requirements for the Information Card

The University of Michigan Transportation Research Institute (UMTRI) and the Children's Hospital of Philadelphia (CHOP) cautioned that removing all style and language requirements could hamper the goals of increasing registration numbers. CHOP recommended that all materials be written at a 3rd-5th grade reading level to ensure that all caregivers,

¹²² 57FR41428

¹²³ 70FR53569

regardless of their level of education, will be able to understand the importance of registering and how to do so.

Agency Response

We understand the benefits of CHOP's recommendation on having the registration form text be written at a 3rd-5th grade level to ensure all caregivers will be able to understand the material in the registration form. However, new requirements on readability and how would they be measured is out of scope of this rulemaking. Since there are different readability scales and tools to measure readability, the agency would have to research which scale and methods are most appropriate to evaluate readability consistently so that the requirements are enforceable. We appreciate the thoughtfulness of CHOP's comment and recommend that CRS manufacturer consider developing their registration forms with this issue in mind.

Mandatory Statement to Distinguish the Information Card

In addition to the style and language aspects of the information card, NHTSA also proposed to permit or possibly require a statement to be present on the information card that informs the CRS owner that the information collected through the registration process is not a warranty card and that the information will not be used for marketing purposes. Comments were generally supportive of requiring such a statement on the information card.

Agency Response

NHTSA supports inclusion of the statement on the information card and is expressly permitting its inclusion. However, NHTSA has decided not to require the statement. Part of the goal of this rule is to provide increased flexibility to manufacturers to drive more effective registration cards, and the agency does not know how a mandated statement may limit the design choices manufacturers make in designing their information cards. In some instances, the statement may take away from the overall goal of a specific design. From the agency's point of view, inclusion of the statement may be beneficial in some instances, but to be consistent with NHTSA's goal to increase manufacturer creativity on information cards, the agency believes

inclusion of such a statement is the manufacturer's choice, not the agency's. Accordingly, NHTSA agency has decided not to mandate the statement at this time.

Electronic Registration Form

In addition to the amendments to the information card, NHTSA has also decided to adopt the NPRM's proposals to the electronic registration form.

FMVSS No. 213 currently permits manufacturers to provide a web address on the information card to enable owners to register online (S5.8.1(d)). The web address must provide a direct link to an "electronic registration form" meeting the requirements of S5.8.2 of the standard. Under S5.8.2, the electronic registration form must conform to a specified format and include certain content, including: (a) A prescribed message to advise the consumer of the importance of registering; (b) prescribed instructions on how to register; and (c) fields to record the CRS's model name or number and date of manufacture, and the owner's name, mailing address, and optionally, the owner's email address.

The NPRM proposed to amend S5.8.1(d) so that the electronic form may be reached by using methods other than a web address, such as a QR code or tiny URL. NHTSA also proposed to change the requirements of (a) and (b) above, from NHTSA-prescribed messages to messages crafted by the CRS manufacturer.

Comments regarding these two proposals were overwhelmingly positive and the agency has decided to adopt the proposals for the reasons stated in the NPRM. However, Graco commented that scannable registration aids should only use open-source or non-proprietary methods and not require consumers to install any special software onto their cell phone. Additionally, Graco recommended that where a scannable graphic is used, a full or reduced sized URL should be printed on the information card to allow direct access to the registration website. In response, NHTSA believes that prohibiting the installation of specific software – such as a QR code reader – would defeat the purpose of exploring different electronic means of registration, as some CRS purchasers may have cell phones without QR code reader software installed.

Accordingly, the agency has decided against Graco's recommendation to prohibit the prompt to install specific software when scanning a QR code. Regarding Graco's second comment, NHTSA agrees that requiring a printed URL on the information card allowing direct access to the registration website would ensure the consumer could reach the registration page if they do not have the technology or ability to scan the QR code. Therefore, NHTSA is adopting this recommendation as part of the final rule.

Mail-In Card

The NPRM sought comment on whether other elements should be added to or eliminated from the currently required mail-in card, and if leeway should be given on how the mail-in card is formatted.¹²⁴ NHTSA received only one comment regarding the mail-in card. Graco commented that it would be beneficial to include a space on the mail-in form for a purchaser to input their telephone number. NHTSA agrees that receiving telephone numbers from CRS purchasers will give manufacturers increased flexibility to communicate with owners about potential recalls. Accordingly, NHTSA is adopting the requirement that a space for a telephone number (provided at the consumer's option) be included on the mail-in card as well as on all electronic registration forms as part of the final rule. FMVSS No. 213 Figure 9a has been updated accordingly to reflect this amendment.

Detachable Mail-In Card

The agency requested comment on whether a two-part registration form was warranted, and, proposed that manufacturers can decide how the information card is attached to the mail-in card.¹²⁵ The agency also stated in the NPRM that the mail-in card portion should be easily detachable from the mail-in card portion without the use of scissors and the like. NHTSA did not receive any comments on this aspect. This final rule provides the proposed flexibility on how the

¹²⁴ 85 FR at 69426, col. 1.

¹²⁵ 85 FR at 69425, col. 3.

information card is attached, while specifying that the information card should be easily detachable.

Information on Labels and Printed Instructions (Owner's Manuals)

The NPRM proposed that provisions in FMVSS No. 213 requiring information on registering CRSs on child restraint labels and in owner's manuals also be amended to reflect the adopted changes.¹²⁶ NHTSA did not receive any comments on this proposal. The agency has adopted this proposal for the reasons provided in the NPRM.

3. Other Issues

SBS recommended that NHTSA create a focused campaign to emphasize the importance of caregivers registering their CRS. SBS indicated that combining registration with a perk like an extended warranty could help increase registration rates. This final rule is focused on amending the style requirements for the information and mail-in card, so a focused media campaign would be outside the scope of this rulemaking. That being said, NHTSA will continue to work toward raising awareness surrounding the importance of registering CRSs. NHTSA also encourages any effort by industry to incentivize registration.

Salem-Keizer Public Schools suggested adding a requirement that manufacturers send an electronic receipt for electronic CRS registrations, and that the receipt should indicate the date when the CRS owner will no longer be notified of a potential recall. NHTSA has decided not to include this requirement in the final rule. CRS manufacturers may consider sending this information voluntarily. If a manufacturer sends an electronic registration receipt shortly after a consumer registers, NHTSA considers such a receipt as part of the registration process. Thus, such a communication would be consistent with our expectation that the consumer information gathered by the caregiver's registration will only be used for recall purposes. NHTSA views a registration receipt as acceptable as long as it is sent shortly after the registration and the content of the receipt only conveys information related to the registration.

¹²⁶ 85 FR at 69426.

4. Summary

NHTSA believes that the amendments to FMVSS No. 213 discussed above will increase registration rates and by extension, recall completion rates. The amendments will enhance the visibility of the registration program by allowing manufacturers additional creativity in their messaging, while at the same time increasing ease of registering by taking advantage of modern technology. Improving messaging and ease of registration will increase CRS recall completion rates and lead to improved safety outcomes for child passengers.

b. Information on Correctly Using CRSs

1. Background

This final rule amends multiple labeling and owner use information requirements under FMVSS No. 213. Specifically, the rule addresses multiple aspects of FMVSS No. 213 S5.5 and S5.6. The safety need addressed by this final rule is to increase the number of children properly secured in child restraint systems, which includes correctly using the child restraint that is appropriate for the child's size. This need exists for both add-on (portable) child restraints and built-in child restraints. (These terms are defined in FMVSS No. 213, S4.) Thus, the rule amends the labeling and owner use information requirements for add-on and built-in child restraints.

The NPRM proposed three amendments to the labeling requirements outlined in S5.5 and S5.6: (1) Requiring that manufacturers that sell CRSs that can be used in multiple "modes" (forward or rearward) provide information about the weight and height of children for each mode of use; (2) requiring that CRSs may only be recommended for forward-facing use by children weighing a minimum of 12 kg (26.5 lb); (3) requiring that the recommended use of a booster seat be increased from the minimum of 13.6 kg (30 lb) to 18.2 kg (40 lb). In addition to these three amendments, the NPRM also proposed easing labeling restrictions to allow manufacturers increased flexibility in conveying use information to consumers.

There were a total of 18 comments regarding these sections of the NPRM. There was general support for the proposed labeling changes. Most of the comments regarding the three

proposals were supportive, but some comments did recommend different amendments for various reasons. As discussed in detail below, NHTSA will be adopting the three proposals.

NHTSA will also be adopting the NPRM's proposed changes that ease labeling requirements. JPMA commented that giving manufacturers flexibility to use their own language and diagrams on labels could better facilitate the production of certain CRS models that are compliant with regulations in multiple countries, including Canada. JPMA also noted that decreasing the need for separate labeling could help reduce overall production costs and aid in keeping CRSs affordable. Comments to the NPRM's proposal to delete paragraph S5.5.2(k)(2) from FMVSS No. 213 were also generally supportive. Graco indicated that the requirement has created confusion for caregivers as to the actual maximum permitted rear-facing weight limit for their child restraint, and that the information consumers need to make the right usage decisions based on their child's weight and height will be better provided on the label(s) containing the information specified in paragraph S5.5.2(f). NHTSA agrees and will be deleting paragraph S5.5.2(k)(2) in this final rule.

2. Labeling by Mode Use

NHTSA and the entire child passenger safety community strongly recommend that children up to the age of 1 ride rear-facing at least up to the age of 1. NHTSA further recommends that children 1 to 3 years of age ride rear-facing for as long as possible, until they reach the manufacturer-recommended upper height or weight limit for riding rear-facing in the CRS. Finally, NHTSA recommends that children 4 to 7 years of age ride forward-facing in CRSs with internal harnesses so long as they are within the height and weight limits of their particular CRS, as established by the CRS's manufacturer.

Currently, FMVSS No. 213 S5.5.2(f) requires a statement, for the overall maximum and minimum height and weight ranges of the children for whom the CRS is recommended, which are not broken down by modes of use. This can result in confusion for caretakers, as the information only tells the caretaker whether that CRS is appropriate for their child, but not

whether it is appropriate for the child to face forward or rearward in a convertible CRS. For example, consider a convertible CRS that states it is fit for use by children weighing 5 to 65 lb (2.3 to 29.5 kg) and with heights up to 48 inches (121.9 cm). Under the current standard, this would comply with the requirements under FMVSS No. 213 S5.5.2(f). In this scenario, a caretaker has no way of knowing what the height and weight limits are for forward- and rear-facing use. NHTSA proposed to amend the requirements such that manufacturers that sell CRSs that can be used in multiple “modes” (forward and rearward facing) would have to provide information about the weight and height of children for each mode of use.

Comments and NHTSA’s Response

The comments were overwhelmingly supportive regarding the NPRM proposal to require CRS manufacturers to provide use information that describes the height and weight recommendations for each mode of use in which the CRS can be used. Accordingly, NHTSA is adopting this requirement for the reasons explained in the NPRM.

Graco suggested that all proposed changes affecting labels become mandatory concurrently. Additionally, Graco suggested that manufacturers be provided the option to relocate the information in S5.5.2(f) upon issuance of the final rule or a short time thereafter. NHTSA is establishing a 1-year compliance date for the labeling requirements as well as allowing early compliance. This gives flexibility to the manufacturers on when they want to introduce those changes. However, if Graco is asking whether it may meet only amended S5.5.2(f) early and not the other amendments to FMVSS No. 213, NHTSA’s answer is no. If a manufacturer chooses to implement early an amendment that has a compliance date of one year, it must implement all the amendments that have a one-year compliance date. This issue is further discussed in the Lead Time and Compliance Dates section of this preamble.

3. Increasing the Forward-Facing Weight Recommendation

As discussed in the section above, NHTSA and the entire child passenger safety community agree that children up to the age of 1 should be kept riding rear-facing at least up to

the age of 1. However, under the current standard, over half the children under 1 year of age do not fall under the recommendation. The current standard – FMVSS No. 213 S5.5.2(k)(2) – sets the minimum weight recommendation for a child in a forward-facing CRS at 9 kg (20 lb). A 50th percentile 1-year-old weighs 9.9 kg (22 lb), which makes the 9 kg (20 lb) threshold far too low.

CRSs used rear-facing support the infant or toddler’s posterior torso, neck, head, and pelvis, and help to distribute crash forces over the strongest parts of the infant or toddler’s body. Developmental considerations, including incomplete vertebral ossification, more horizontally oriented spinal facet joints, and excessive ligamentous laxity put young children at risk for head and spinal injury. CRSs used rear-facing address this risk by supporting the child’s head, preventing the relatively large head from moving independently of the proportionately smaller neck.

Although NHTSA recommends that children 1 to 3 years old ride rear-facing in the appropriate CRSs for as long as possible to address the above risks, many caregivers are not following this recommendation and instead appear to be following labeling instructions that specify a turnaround weight of 9 kg (20 lb). While the instructions comply with FMVSS No. 213, they have led to less-than-optimal positioning of infants and toddlers in vehicles. NCRUSS data indicate that, among children weighing less than 9 kg (20 lb), 93 percent were restrained in a CRS rear-facing, yet among children weighing 9 to 13.1 kg (20 to 29 lb), only 22 percent were restrained rear-facing in a CRS. The agency proposed to require that CRSs may only be recommended for use in the forward-facing direction by children weighing a minimum of 12 kg (26.5 lb), which corresponds to the weight of a 95th percentile 1-year-old, a 75th percentile 18-month-old and about a 50th percentile 2-year-old.

Comments and NHTSA’s Response

Comments were generally supportive of the increase in turnaround weight from 9 kg (20 lb) to 12 kg (26.5 lb). All comments on this issue supported an increase, but some comments

recommended a different weight. For the reasons discussed below, NHTSA has decided to adopt the 12 kg (26.5 lb) increase in this final rule.

The American Academy of Pediatrics (AAP), UMTRI, and Safe Ride News (SRN) recommend an increase to 13.6 kg (30 lb). AAP states that, “Most rear-facing-only and convertible seats currently on the market can accommodate a 30-lb child rear-facing,” and that increasing the recommendation to 30 lb would help demonstrate to caretakers the benefits of keeping their child rear-facing as long as possible. UMTRI argues that a 30 lb recommendation would correspond to a 75th percentile 2-year-old, encompassing more of that age group than the proposed 26.5 lb recommendation. SRN notes that a 30 lb recommendation would be an easier weight milestone for caretakers to track and that it would be preferable to well exceed the weight of a 95th percentile one-year-old.

While NHTSA understands the arguments in favor of this recommendation, increasing the turnaround weight to 13.6 kg (30 lb) would be substantially beyond the minimum recommendation for all 1-year-old children riding rear-facing. We believe it would be best to thoroughly vet possible unintended consequences of a 13.6 kg (30 lb) limit for forward-facing CRSs prior to making such a change. One concern relates to how a change to 13.6 kg (30 lb) might curtail the ability of low-weight older children (e.g., 4- and 5-year-old children who are 1st to 5th percentile in weight) to ride in forward-facing CRSs when the children outgrow a CRSs used rear-facing because of their height. A 13.6 kg (30 lb) turnaround weight may limit the availability of any kind of child restraint system for these children as the children would be too tall for CRSs used rear-facing but under the 13.6 kg (30 lb) turnaround height. If CRSs were unavailable, a caregiver might place the child in the vehicle seat belt alone, significantly raising the safety risk to the child in a crash. NHTSA believes it would be prudent to thoroughly investigate unintended consequences, such as the one described above, that may result from raising the turnaround weight to 13.6 kg (30 lb).

Britax, JPMA, SRN, Graco, and Consumer Reports comment that, instead of a number with a decimal (26.5 lb), it would be beneficial to use a whole number, as caregivers likely don't track their child's weight down to the half-pound. Graco commented that the number should be a multiple of 5 suggesting a 25 lb weight should be adopted. NHTSA disagrees with establishing a whole number in the standard in this case. Lowering the figure to 11.7 kg (26 lb) would decrease the population NHTSA is trying to target (95th percentile 1-year-old children). On the other hand, increasing the figure to 12.2 kg (27 lb) would slightly increase the population NHTSA is trying to target, but would still not be a multiple of 5 as Graco suggested. The 12 kg (26.5 lb) weight transition is a minimum number and manufacturers can choose a round number greater than 26.5 that best accommodates their CRS design, if they wish to do so.

Graco, SRN, and Volvo recommend using age recommendations as opposed to weight recommendations. NHTSA disagrees that using age as a criterion is preferable to using weight and height, as CRSs are designed and recommended by the manufacturer using weight and height. NHTSA is using weight in lieu of age by establishing minimum weight limits that correspond to the 95th percentile 1-year old child. This ensures that children up to 1 year of age are in CRS that are facing rearwards. The updated minimum child weight recommendation for CRSs that are used in a forward-facing mode aligns the standard to NHTSA's car seat recommendations, which are age based, but also refer to the weight and height recommendations of the CRS.

Also, weight and height characteristics are the most relevant parameters affecting crash force mitigation, rather than a child's age. The standard selects the different child dummies used to evaluate CRSs based on the CRS's weight and height recommendations to ensure the CRS is engineered to safely attenuate and manage crash forces when used by a child who is within the CRS's child weight or height recommendations.

Some commenters support an age recommendation to increase the likelihood that a child would be mature enough to stay properly seated in a CRS (particularly a booster seat). FMVSS

No. 213 permits CRS manufacturers to include an age recommendation, as long as that recommendation does not conflict with FMVSS No. 213's requirements. S5.5 states, in pertinent part: "Any labels or written instructions provided in addition to those required by this section shall not obscure or confuse the meaning of the required information or be otherwise misleading to the consumer."¹²⁷ Accordingly, NHTSA will not be including an age recommendation as part of the final rule. CRS manufacturers may choose to include an age recommendation for their CRSs, including booster seats, provided the age recommendation comports with S5.5 and all other applicable requirements of FMVSS No. 213.

SBS states that labeling and public messaging on the increase of the minimum forward-facing CRS weight limit should be carefully crafted to avoid conflicting with either best practice recommendations or State laws. (The commenter states: "26.5 lbs. is rarely the correct weight for children to ride forward facing by these metrics.") The commenter appears concerned about the interplay of an FMVSS No. 213 turnaround weight of 26.5 lb with best practice recommendations, and State law requirements, that children ought to ride rear-facing until, e.g., a particular age. In response, the increase to 12 kg (26.5 lb.) establishes a minimum turnaround weight; it does not require manufacturers to specify that the child *must* ride forward-facing at 12 kg (26.5 lb). It re-sets the minimum for the turnaround weight by prohibiting manufacturers from instructing that a child weighing less than 12 kg (26.5 lb) may ride forward-facing. The new turnaround weight (increased from the current 20 lb turnaround weight) is more consistent with current recommendations on when to transition a child to forward-facing, meaning this amendment to the standard will bring it more in line with best practice recommendations and related State laws.

4. Increasing the Belt-Positioning Seat Weight Recommendation

¹²⁷To illustrate, the age recommendation cannot contradict the requirement that booster seats must only be recommended for children weighing more than 40 lb. Thus, by way of example, manufacturers are not permitted to recommend a booster for use by 2- or 3-year-olds.

NHTSA believes that FMVSS No. 213 currently permits manufacturers to recommend moving children from a CRS with an internal harness to a belt-positioning seat (“booster seat”) too soon. Although NHTSA recommends that children riding forward-facing should remain in a CRS with an internal harness for as long as possible before transitioning to a booster seat, FMVSS No. 213 S5.5.2(f) currently permits booster seats to be recommended for children weighing 13.6 kg (30 lb). Thirty pounds corresponds to the weight of a 50th percentile 3-year-old, and the weight of a 95th percentile 18-month-old. The 2020 NPRM proposed increasing the recommended booster seat weight to 18.2 kg (40 lb)¹²⁸ which is greater than the weight of a 97th percentile 3-year-old (17.7 kg (39.3 lb)) and approximately the weight of an 85th percentile 4-year-old. This change in minimum child weight recommended for booster seat use to 18.2 kg (40 lb) would result in more 3- and 4-year-old children being transported in forward-facing CRSs with an internal harness. In the NPRM, NHTSA cited a 2010 study (“2010 study”) based off exclusively NASS-CDS data to explain why the agency proposed to increase the booster seat weight recommendation to 18.2 kg (40 lb).¹²⁹

Comments Received

There were no comments that opposed changing the minimum weight recommendation for belt-positioning seats from 13.6 kg (30 lb) to 18.2 kg (40 lb). Commenters agreed that adopting this amendment would help prevent early transition to boosters, reduce injuries and fatalities of 3- and 4-year-olds, and harmonize the FMVSS with a counterpart Canadian CRS standard. However, several commenters (Dorel, the Insurance Institute for Highway Safety (IIHS), JPMA, a private individual) state that NHTSA should not use NHTSA’s 2010 study (“the 2010 study”) as a justification for the amendment.

Agency Response

¹²⁸ As discussed previously, the standard uses weight in lieu of age.

¹²⁹ Sivinski, R. “Booster Seat Effectiveness Estimates Based on CDS and State Data”. July 2010. DOT HS 811 338.

NHTSA's 2010 study recognized that there were limitations to the conclusions that could concretely be drawn from the study because of how sparse the child occupant data were in the sample. The 2010 FARS data files did not distinguish belt-positioning seats from CRSs with internal harnesses. Because of this, the 2010 study could not use the FARS census data to compare the performance of belt-positioning seats to CRS with harnesses. The 2010 study instead used unweighted NASS/CDS sample data, despite the sparse nature of the child occupant data in NASS/CDS, and supplemental state data, because those were the data available to the agency at the time. Because of the sparse nature of the data, the unweighted data with supplemental state data had to be weighted for the analysis.

NHTSA recognized the limits of the 2010 study from the very beginning, and in December 2020 NHTSA published a new study ("the 2020 study") examining the effectiveness of different types of CRSs in mitigating both nonfatal injuries and fatalities to 1- to 8-year-old children and compared them to children restrained only by seat belts.¹³⁰ The 2020 study was published after the 2020 NPRM and therefore the 2020 study was not available for discussion in the NPRM.

The 2020 study addressed the shortcomings of the 2010 study. In the 2020 study, NHTSA examined the effectiveness of different types of CRSs (CRSs with internal harnesses, and belt-positioning seats) in mitigating both nonfatal injuries and fatalities to 1- to 8-year-old children compared to children restrained only by seat belts. For this analysis, the agency found that FARS data for 2009 and 2016 distinguished CRSs with harnesses from booster seats. These data were not available at the time the 2010 study was published. The agency conducted the analysis in the 2020 report using NASS-CDS data for the years 1998 to 2015 for evaluating effectiveness of CRSs with internal harnesses and belt-positioning seats in mitigating moderate-to-critical injuries and serious-to-critical injuries. The FARS data for the years 2009 to 2016

¹³⁰ Pai, J.-E. "Evaluation of child restraint system effectiveness," December 2020. DOT HS 813 047. Docket No. NHTSA-2020-0093-0054

were used to evaluate the effectiveness of CRSs with internal harnesses and belt-positioning seats in mitigating fatalities.

The presence of the FARS data alleviates most, if not all, of the concerns raised by commenters who pointed out the weaknesses of the 2010 study. The NASS-CDS data analysis in the 2020 study was conducted using the maximum abbreviated injury (MAIS) scale, which is significantly more robust than the KABCO injury scale used in the 2010 study. The child age groups considered in the 2020 analyses were 1 to 3-years-old, 3 to 5-years-old, 4 to 8-years-old and 7 to 8-years-old. Logistic regression analysis of the weighted sample data was conducted. The analysis considered various domain variables, including the type of crash, driver characteristics, child occupant seating position, and restraint type used.

The FARS data analysis in the 2020 study considered vehicles of model years 1999 to 2017, with drivers restrained by seat belts and air bags. The 2020 study used the same child age groups as in the NASS-CDS analysis. The effectiveness of CRSs with internal harnesses and belt-positioning seats in mitigating fatalities was evaluated using double paired comparison analysis as well as logistic regression. The analysis of the FARS datafiles in the 2020 study found similar results to the 2010 study from a double paired comparison analysis as well as the logistic regression. The analysis considered driver restraint status and crash type to mitigate confounding effects on the results.

Dorel expressed concern that NHTSA asserted in the NPRM that children who weigh more than 18.2 kg (40 lb) are “better protected” in a CRS with harness than in a belt-positioning seat. The agency believes Dorel misunderstood the statement in the NPRM that, “NHTSA believes that if belt-positioning seats were only recommended for children weighing a minimum of 18.2 kg (40 lb), more 3- to 4-year-olds will be transported in CRSs with internal harness, where they are better protected at that young age, than in booster seats,”¹³¹ and offers the following detailed explanation for clarity.

¹³¹ 85 FR at 69390

The 2010 study and the 2020 study used child age to evaluate the effectiveness of CRSs with internal harnesses and belt-positioning seats instead of physical characteristics such as weight and height of the child. This is because weight and height information are not available in many cases, which would result in a high percentage of missing values. The 2020 study considered age groups to permit sufficient observations in each of the categories under evaluation. For example, in the 3- to 5-year-old age group, among children in CRSs with internal harnesses, 46 percent were 3-year-olds while only 19 percent were 5-year-olds. Similarly, for this age group, among children in belt-positioning seats, 19 percent were 3-year-olds while 47 percent were 5-year-olds.

Since the weight and height of children vary considerably, there is no one-to-one correspondence between the child age and height and weight of the child. However, as noted in the NPRM, nearly all 3-year-old and about 87 percent of 4-year-old children weigh less or equal to 18.2 kg (40 lb). Additionally, about 25 percent of 5-year-old children weigh less than or equal to 18.2 kg (40 lb). Because of the range in child height and weight for a specific age, NHTSA requires specification of the child weight and height in labels for recommended use of CRSs.

The 2020 study found that for 1- to 3-year-old children, CRSs with internal harnesses were 47.3 percent more effective in mitigating fatalities than belt-positioning seats, and nearly all 1- to 3-year-old children weigh less than 18.2 kg (40 lb). NHTSA proposed an 18.2 kg (40 lb) minimum limit for belt-positioning seat use. Since about 87 percent of 4-year-old children and 25 percent of 5-year-old children also weigh less than 18.2 kg (40 lb), these children would also be recommended to be restrained in CRSs with internal harnesses. The 2020 study found that for 3- to 5-year-old children, CRSs with internal harnesses were 43.1 percent more effective in mitigating fatalities than belt-positioning seats. From these data, NHTSA concludes children in this age group who weigh less than 18.2 kg (40 lb) would also benefit from the increase in the minimum child weight for recommending belt-positioning seat use from 13.6 to 18.2 kg (30 to 40 lb). The effect would be that all 3-year-old children, 87 percent of 4-year-old children, and

about 25 percent of 5-year-old children would be recommended to be restrained in CRSs with internal harnesses. This could result in more 3- and 4-year-old children in CRSs with internal harnesses than in belt-positioning seats, and thereby reduced child occupant crash fatalities. As stated above, NHTSA will be adopting the 18.2 kg (40 lb) proposal from the NPRM as part of the final rule, and the agency believes that the 2020 study is a sufficient justification for doing so as it alleviates many of the concerns with the 2010 study.

5. Suggested Additional Booster Seat Labeling

AAP suggests it would be beneficial to have an additional label indicating that a child must be developmentally mature enough to sit properly in a booster seat. NHTSA disagrees that adding this labeling requirement would be appropriate, as the agency is concerned about the efficacy of such a label. Readiness for a booster is a subjective determination that could change depending on a caregiver's judgment of and experience with the child. An agency-worded instruction on how to analyze a child's behavioral characteristics may not be productive. Accordingly, NHTSA will not be including a behavioral labeling requirement as part of the final rule. We note, however, that FMVSS No. 213 permits CRS manufacturers to include this kind of information on the booster label or in the written instructions provided with the restraint, as long as the information does not "obscure or confuse the meaning of the required information" or is "otherwise misleading to the consumer" (S5.5 in FMVSS No. 213).

Dorel, CHOP, and SRN comment that public messaging for booster seat use should be done carefully so that caregivers do not misinterpret the reason behind amending the standard. These commenters were generally concerned with caregivers thinking that current CRSs on the market targeted at children between 30 to 40 pounds are unsafe, and instead of utilizing those CRSs, they will seat their child without a CRS or booster seat. NHTSA agrees that public messaging is important, and all labeling changes should be communicated to the consumer in the clearest manner possible. We note that, because the labeling change will bring the standard more

closely in-line with NHTSA's booster seat recommendations, this change will likely make the messaging from NHTSA on booster seats clearer.

SRN and Volvo suggest that a minimum age be included as a requirement for transitioning to booster seats. NHTSA does not agree that including an age requirement would be appropriate or beneficial. The agency believes particularly strongly about this in the context of booster seats since children of the same age can vary greatly in size. Not all forward-facing CRSs in the market can fit all children less than 5 years old. If a 5-year-old or younger child outgrows their forward-facing CRS due to weight or height but could not be put into a booster seat because of age restrictions on a label, a caregiver would have to acquire another harnessed-CRS or may decide to transport the child without either a CRS with internal harness or booster seat. Purchasing another CRS with internal harness is an expense that many consumers may not be willing to make and transporting the child in a seat belt alone presents serious safety risks. Accordingly, after considering these potential consequences, the agency has decided against including a minimum age requirement for transitioning to a belt-positioning seat.

Volvo comments that children should use booster seats as soon as they are big enough and mature enough to use them so that children can take advantage of a vehicle's advanced seat belt functions. NHTSA disagrees with Volvo, as the FARS data (2009-2016) discussed above indicate that for all crashes, the risk ratio of a fatality for 3- to 5-year-old children restrained in a forward-facing CRS with a harness is 45.6 percent less than the fatality risk for 3- to 5-year-old children restrained with a booster seat. Volvo did not present any data supporting its claims, whereas these data indicate that the children that were restrained in forward-facing CRSs with an internal harness were better protected than children restrained in a booster seat with a vehicle seat belt.

6. Other Recommendations About Labels

SRN commented that NHTSA should encourage an industry-wide approach to redesign labels to ensure consistency of public messaging and to guard against conflicting usage

recommendations. NHTSA believes collaboration efforts by industry to optimize CRS labeling is a worthy pursuit. NHTSA is providing flexibility with this final rule, however, and does not believe it would be appropriate to mandate a universal approach to label design as that would essentially replicate the status quo. The agency does not wish to negate any of the benefits that could be gained by giving industry the leeway to design their labels using the words and diagrams they feel is most appropriate for their consumers.

SRN and SBS recommend that NHTSA require a permanent, visible indicator on all CRSs to communicate maximum child height for riding in the CRS. SRN argues that this option is superior to a maximum rear-facing height and weight recommendation and could be provided at little cost to manufacturers. SBS recommends that this visual indicator be mandatory and be located 25 mm (1 inch) below the top of the CRS shell. Although NHTSA agrees that a visual landmark to help the consumer recognize when the child has reached the recommended height may have benefits, the agency has decided not to adopt this recommendation as part of the final rule. For one thing, requiring a 25 mm (1 inch) mark is beyond the scope of this rulemaking. Second, NHTSA is unable to agree that mandating a 25 mm (1 inch) indicator below the top of the CRS shell is the best way forward. We believe CRS manufacturers may want to estimate this visual landmark in a different way, and they are currently free to do so. Further, NHTSA does not currently know if the 25 mm (1 inch) below the top of the CRS shell is an appropriate distance for current CRS designs and in any future designs. NHTSA has not determined if the 25 mm (1 inch) distance is the most effective distance from the head to the top of the CRS shell to mitigate severe injuries or fatalities.

7. Summary

Similar to the agency's approach to the CRS registration form, NHTSA is allowing manufacturers more creative freedom to communicate with their customers on labels, as manufacturers best know their customers and have the resources and expertise to maximize communication with them. CRS misuse and installation mistakes remain a significant problem.

The agency reviewed all NASS-CDS and Crash Injury Research and Engineering Network (CIREN) data files for the years 2003 to 2013 for instances in which children 12-YO and younger in CRSs in rear seats of light passenger vehicles sustained AIS 3+ injuries in frontal crashes without rollover. The most frequent cause of AIS 3+ injury to children, at 39 percent, was gross CRS misuse. This final rule will provide manufacturers the opportunity to develop and implement targeted messaging on correct CRS use that could reduce the extent of CRS misuse. NHTSA believes the market provides a significant incentive to designing effective labeling and diagram designs, and an effective deterrent from designing ineffective labeling and diagram designs. Nonetheless, NHTSA will continue to monitor CRS labels and instructions to see how the information changes over time and whether agency action is necessary.

IX. Streamlining NHTSA's Use of Dummies in Compliance Tests to Reflect CRS Use Today

a. Introduction

All child restraint systems must meet FMVSS No. 213's performance requirements when dynamically tested with dummies that represent children of various ages. The current dummies used in compliance testing of add-on and built-in child restraints are the newborn infant, the CRABI-12MO, the HIII-3YO, the HIII-6YO, the H2-6YO, the weighted HIII-6YO, and the HIII-10YO child dummy.¹³²

NHTSA selects the test dummy used in a particular test based in part on the height (regardless of weight) or weight (regardless of height) of the children for whom the manufacturer recommends for the child restraint (S7). Table 8 below shows which dummies NHTSA uses to test child restraints based on the height or weight recommendations established for the restraint by the manufacturer. If a child restraint is recommended for a range of children whose weight or

¹³² NHTSA also recently adopted a three-year-old child side impact test dummy (Q3s) for use in side impact tests of add-on CRSs. Final rule adopting FMVSS No. 213a; 87 FR 39234, June 30, 2022, *supra*.

height overlaps, in whole or in part, two or more of the weight or height ranges in the table, the restraint is subject to testing with the dummies specified for each of those ranges.

Table 8: Current use of dummies based on manufacturer’s recommendation (S7)

| CRS Recommended For Use by Children of These Weights or Heights-- | Are Compliance Tested by NHTSA With These Dummies (Subparts Refer to 49 CFR Part 572) |
|--|---|
| Weight (W) ≤ 5 kg (11 lb) Height (H) ≤ 650 mm (25.5 inches) | Newborn (subpart K) |
| Weight 5 kg (11 lb) < W ≤ 10 kg (22 lb) Height 650 mm (25.5 inches) < H ≤ 850 mm (33.5 inches) | Newborn (subpart K), CRABI-12MO (subpart R) |
| Weight 10 kg (22 lb) < W ≤ 18.2 kg (40 lb) Height 850 mm (33.5 inches) < H ≤ 1100 mm (43.3 inches) | CRABI-12MO (subpart R), HIII-3YO (subpart P) |
| Weight 18kg (40 lb) < W ≤ 22.7 kg (50 lb) Height 1100 mm (43.3 inches) < H ≤ 1250 mm (49.2 inches) | HIII-6YO (subpart N) or H2-6YO (subpart I) (manufacturer’s option) |
| Weight 22.7 kg (50 lb) < W ≤ 30 kg (65 lb) Height 1100 mm (43.3 inches) < H ≤ 1250 mm (49.2 inches) | HIII-6YO (subpart N) or H2-6YO (subpart I) (manufacturer’s option), and weighted HIII-6YO (subpart S) |
| Weight greater than 30 kg (65 lb) Height greater than 1250 mm (49.2 inches) | HIII-10YO (subpart T)* |

* No HIC measured with HIII-10YO

(Note: Add-on CRSs with internal harnesses that, together with a dummy, weigh more than 30 kg (65 lb), are not tested with the dummy while attached to the standard seat assembly using the child restraint anchorage system. Instead, they are attached to the standard seat assembly using the seat belt system.)

b. Testing CRSs for Children Weighing 10 - 13.6 kg (22 - 30 lb)

Currently under FMVSS No. 213, CRSs labeled for use by children in the weight range 10 kg to 18.2 kg (22 lb to 40 lb) per Table 8 are subject to testing with the CRABI-12MO and the HIII-3YO dummy (S7.1.2(c)). NHTSA proposed amending S7.1.2(c) by splitting the 10 to 18.2 kg (22 to 40 lb) weight range into a 10 to 13.6 kg (22 to 30 lb) and a 13.6 to 18.2 kg (30 to 40 lb) weight range per Table 13. We proposed that CRSs recommended for children in the 10 to 13.6 kg (22 to 30 lb) weight range would be tested with the CRABI-12MO, while CRSs for children

in the (13.6 to 18.2 kg (30 to 40 lb)) weight range would be tested with the HIII-3YO.¹³³ NHTSA proposed this change because, as a practical matter, 3-year-olds are generally too large to fit in a CRS recommended for children in the 22 to 30 lb weight range.

NHTSA discussed in the NPRM the anticipated effect that the amendment would have on infant carriers.¹³⁴ The current CRS market has infant carrier models recommended for children weighing up to 10 kg (22 lb), 13.6 kg (30 lb), 15.8 kg (35 lb), and 18.2 kg (40 lb) and with child height limits ranging from 736 mm (29 inches) to 889 mm (35 inches). The agency expects that manufacturers will reduce the maximum weight recommendations such that the restraints will be marketed for children up to 13.6 kg (30 lb), in part because it will be easier to certify CRS for children in this weight range with only the CRABI-12MO dummy than in the wider weight range which will require certification with multiple dummies. Further, NHTSA does not believe there will be market demand for infant carriers that are recommended for children weighing more than 13.6 kg (30 lb). Feedback from child passenger safety technicians involved in child restraint system checks indicates that infants usually outgrow infant carriers because of reaching the height limit of the carrier rather than the weight limit. Further, as an infant reaches a 13.6 kg (30 lb) weight, the weight of the infant and the infant carrier together becomes too heavy for a caregiver to easily pull out of the vehicle and carry around by a handle. Therefore, parents often switch to a convertible or all-in-one CRS as the child weight nears 13.6 kg (30 lb).

Commenters generally supported or did not oppose the proposal, but Consumer Reports and Evenflo raised issues that we address below.

¹³³ As a practical matter, most CRS would be subject to testing using at least two dummies since most CRS are sold for children of weights spanning more than one weight category. A CRS that is recommended for a weight range that overlaps, in whole or in part, two or more of the weight ranges is subject to testing with the dummies specified for each of those ranges (571.213, S7).

¹³⁴ An infant carrier is a rear-facing CRS designed to be readily used in and outside of the vehicle. It has a carrying handle that enables caregivers to tote child outside of the vehicle without removing the child from the CRS. Prior to this final rule, these infant carriers were subject to testing with the HIII-3YO (35 lb) dummy rear-facing under the provisions of S7. However, NHTSA has not tested infant carriers with the 3-year-old dummy because, among other matters, the dummy did not fit easily in infant carriers with its stature of 945 mm (37.2 inches). Since infant carriers are typically used with infants, and not with 3-year-olds, NHTSA decided to propose not using the 3YO dummy to test infant carriers.

Comments Received and Agency Response

Consumer Reports (CR) suggests that NHTSA should expressly prohibit infant carriers from being recommended for children weighing over 13.6 kg (30 lb), instead of limiting the maximum weight through the new dummy selection criteria for the HIII-3YO dummy. NHTSA does not believe there is a need for this approach. NHTSA believes that infant carrier manufacturers will relabel or redesign their products to adopt the maximum weight recommendation of 13.6 kg (30 lb), to avoid testing with the 3-year-old dummy.

With current infant carrier designs, the 3-year-old dummy's head is above the CRS shell; the dummy's head center of gravity (CG) will exceed the upper head excursion limits when tested. Current infant carriers would have to be redesigned to accommodate a 3-year-old's head height. An infant carrier redesigned to meet FMVSS No. 213 with the HIII-3YO dummy will likely have the utility and weight of a convertible CRS used in the rear-facing mode than the utility and weight of an infant carrier, which consumers may not find suitable for a carrier. We recognize that some manufacturers might choose to continue to produce infant carriers with a maximum weight recommendation over 13.6 kg (30 lb). If this were to happen, NHTSA will include these CRSs in the agency's compliance test program and will test them with the 3-year-old dummy as described in this final rule.

Comment and Response

CR opposed the proposal to remove the CRABI-12MO testing requirement for CRSs with a 13.6 kg (30 lb) to 18.2 kg (40 lb) capacity. The commenter is concerned about infant carriers that may be sold for children weighing over 30 lb. CR stated these infant seats "are designed specifically for newborns and infants and should be tested to ensure that the injury metrics for the average-sized infant using those seats are within the appropriate injury thresholds."

We believe CR has misunderstood the weight thresholds of the NPRM. As explained in the NPRM and in FMVSS No. 213's regulatory text, "If a child restraint is recommended for a

range of children whose weight overlaps, in whole or in part, two or more of the weight ranges in the table, the restraint is subject to testing with the dummies specified for each of those ranges.”¹³⁵ Infant carriers with a 13.6 kg (30 lb) to 18.2 kg (40 lb) weight capacity also have weight recommendations below 13.6 kg (30 lb), usually starting at 1.8 kg (4 lb). Therefore, infant carriers that have an upper limit of 30 to 40 lb, and a lower weight limit below 30 lb, will always be tested with the CRABI-12MO dummy, in addition to being tested with the HIII-3YO under the NPRM and this final rule.

Comment and Response

CR recommends including a weighted CRABI-12MO to test for structural integrity. The commenter states that the weighted dummy changes the dynamics of the CRS and interaction with CR’s testing using a simulated front seat back, often resulting in head contact of the dummy with the seat back “even when height is within the allowable confines of the shell.” CR states that many of the structural integrity issues it has seen have resulted at the upper limit of the CRS weight capacity.

In response, CR’s suggestion to adopt a weighted CRABI-12MO is beyond the scope of the rulemaking. We note also that the FMVSS No. 213 standard sled assembly does not have a simulated front seat, so CR’s experience with the weighted dummy’s head contacting the front seat would not replicate the dynamics CR observed with a weighted CRABI-12MO, or necessarily demonstrate the “structural integrity issues”¹³⁶ the commenter said it found. We also note that CR did not provide information about the structural integrity issues it saw, or data on

¹³⁵ See 85 FR at 69429, col. 3. See FMVSS No. 213 S7: “A child restraint that meets the criteria in two or more of the following paragraphs in S7 may be tested with any of the test dummies specified in those paragraphs.”

¹³⁶ FMVSS No. 213 S5.1.1 has integrity requirements that include no complete separation of any load bearing structural element and no partial separation that expose surfaces with a radius of less than ¼ inch or surfaces with protrusions greater than 3/8 inch above the immediate adjacent surrounding contactable surface of any structural element of the system. NHTSA interprets load bearing structure to mean a structure that: (1) transfers energy from the standard seat assembly to the CRS (*e.g.*, installation components or CRS areas that contact the standard seat assembly), or (2) transfers energy from the CRS to the occupant or vice versa (*e.g.*, belts and components to restrain the child, CRS surfaces or parts transferring energy to the occupant).

the extent to which head to front seat contact and loss of structural integrity are present in the field. We thus do not find a need for a weighted CRABI-12MO.

NHTSA believes infant carriers will most likely be relabeled or redesigned to have a maximum weight of 13.6 kg (30 lb). This final rule will eliminate the weight gap for testing the structural integrity of CRSs now in test protocols where infant carriers recommended up to 20.4 kg (45 lb) are only tested with the CRABI-12MO dummy. NHTSA will monitor the market and our test program results to explore if structural integrity issues arise or if there is a need for additional tests.

Comment and Response

Evenflo points out an incongruity between how we would test with the CRABI-12MO and the provision in the NPRM that CRSs may only be recommended for forward-facing use by children weighing at least 12 kg (26.5 lb). Evenflo requests that the agency clarify how the CRABI-12MO will be used in compliance testing if children represented by the dummy would not be turned forward-facing until 26.5 lb. NHTSA agrees with Evenflo on the need for clarification. We do not believe there is a need to test a forward-facing CRS with the CRABI-12MO (weighing 9.9 kg (22 lb)) because the dummy would be at least 2 kg (4.5 lb) less than the weight of children for whom the CRS in forward-facing mode is recommended. NHTSA is clarifying the regulatory text to make clear that the CRABI-12MO will not be used to test CRS in the forward-facing configuration for CRSs that can be used forward-facing.¹³⁷ However, to be clear, if a CRS can be used both forward-facing and rear-facing, the CRABI-12MO will be used to test the CRS in the rear-facing configuration. Further, this provision only applies to CRSs that are certified to this final rule's new turnaround weight requirement. These will be labeled with a turnaround weight of 12 kg (26.5 lb) or more.

¹³⁷ Evenflo commented that until the 12-month-old dummy is no longer used to evaluate forward-facing CRSs, the \$540,000 cost savings estimated in the NPRM likely will not be realized. We note that the cost savings in the NPRM were related to infant carrier tests with the 3-year-old dummy, which would still be actualized. Removing the CRABI-12-MO forward-facing tests would result in further cost savings.

NHTSA notes that this change has implications for the agency's use of the CRABI-12MO in FMVSS No. 213a (Side Impact Protection) compliance tests, *supra*.¹³⁸ NHTSA plans to issue an NPRM to propose a conforming amendment to FMVSS No. 213a that the CRABI-12MO would not be used forward-facing in the side impact test for CRSs labeled with a turnaround weight of 12 kg.

Height Specifications

This final rule also adopts proposed changes to the standard's height specifications for testing with the dummies so that height categories are consistent with the corresponding weight limits. This is to simplify the standard. Commenters did not oppose the proposal, so it is adopted as discussed in the NPRM.

First, this final rule adopts proposed S7.1.1(c) that specifies that the CRABI-12MO dummy is used to test a CRS recommended for children weighing 10 to 13.6 kg (22 to 30 lb) or children in a height range of 750 mm to not greater than 870 mm. A child weighing 13.6 kg (30 lb) on average is about 870 mm (34.3 inches) tall. If the CRS is recommended for children with heights over 870 mm, the CRS will be subject to testing with the appropriate larger sized dummy.

Second, currently S7.1.2(b) specifies that the newborn and CRABI-12MO dummies are used to test CRSs recommended for children in a height range from 650 mm to 850 mm. The average height of a 12MO child is 750 mm (29.5 inches). This rule reduces the 850 mm limit to 750 mm to correspond to the average height of a 12MO child (750 mm (29.5 inches)).

c. Testing CRSs for Children Weighing 13.6 – 18.2 kg (30 – 40 lb)

This final rule adopts the proposed amendments affecting CRSs labeled for use by children weighing from 13.6 kg to 18.2 kg (30 to 40 lb). Currently, these CRSs are subject to testing with the CRABI-12MO and the HIII-3YO (S7.1.2(c)).¹³⁹ NHTSA determined that the

¹³⁸ Final rule, 77 FR 39234.

¹³⁹ The CRABI-12MO is not used to test a booster seat (S7.1.2(c)).

CRSs do not need to be tested with the CRABI-12MO, since the 10 kg (22 lb) dummy is not representative of 13.6 to 18.2 kg (30 to 40 lb) children for whom the restraint is intended.¹⁴⁰

Commenters were supportive of the change. This final rule adopts a new S7.1.1(d) for the 13.6 to 18.2 kg (30 to 40 lb) range.

The new S7.1.1(d) specifies that NHTSA will test CRSs recommended for children in the weight range of 13.6 kg to 18.2 kg (30 to 40 lb) with the HIII-3YO dummy. Also, to make the height specification for testing with the dummy consistent with the corresponding weight limit, this final rule adopts the proposed provision that NHTSA will use the HIII-3YO dummy to test CRSs recommended for children in the height range of 870 mm to 1,100 mm (34.3 to 43.3 inches), amended from 850 mm to 1,100 mm (33.5 to 43.3 inches) per Table 13.

d. Testing CRSs for Children Weighing 18 - 29.5 kg (40 – 65 lb)—Use of the HIII-6YO Dummy

FMVSS No. 213 currently provides child restraint manufacturers the option of having NHTSA use the HIII-6YO or the H2-6YO in compliance tests of CRSs for children weighing 18 to 29.5 kg (40 to 65 lb) (S7.1.3). The NPRM proposed to remove the option and require that these CRSs be tested only with the HIII-6YO. The agency prefers the HIII-6YO as it is a more biofidelic test device than the H2-6YO, and also because it is becoming increasingly difficult to obtain replacement parts for the older H2-6YO dummy. CRS manufacturers are increasingly using the HIII rather than the H2-6YO dummy to certify their CRSs.¹⁴¹

NHTSA has been interested in using the HIII-6YO in FMVSS No. 213 for many years. We adopted the dummy in the standard in 2003 after determining that the dummy is “considerably more biofidelic”¹⁴² than the H2-6YO dummy and able to measure impact

¹⁴⁰ However, if such a CRS were also labeled for use by children weighing less than 13.6 kg (30 lb), then the CRS is subject to testing with the CRABI-12MO.

¹⁴¹ Information from manufacturers to NHTSA in 2014 showed that 43 percent of CRS manufacturers use the HIII-6YO to test their CRSs, 21 percent use the H2-6YO and 36 percent use both dummies for testing their various CRS models. Manufacturers using both the H2-6YO and HIII-6YO dummies test at least 50 percent of their models using the HIII-6YO dummy.

¹⁴² 68 FR 37644.

responses no other child test dummy could measure, such as neck moments and chest deflection. However, while the dummy is successfully used in FMVSS No. 208 to measure compliance with low-risk deployment and static suppression tests of advanced air bags, problems arose in FMVSS No. 213 testing. In the demanding FMVSS No. 213 test environment where no air bag is present, the HIII-6YO exhibited unrealistic chin-to-chest and head-to-knee contact in tests of booster seats on the current standard seat assembly. The contact resulted in inordinately high, oftentimes failing HIC values recorded by the dummy.

NHTSA responded by adopting a provision permitting the optional use of the H2-6YO dummy in place of the HIII-6YO. NHTSA originally intended the optional use as a short-term measure but after extending the term several times, NHTSA issued a final rule in 2011 to permit optional use of the H2-6YO “until further notice.” The agency believed work was needed on the dummy to ameliorate the chin-to-chest and head-to-knee contact that was driving up the HIII-6YO HIC values.

As discussed in the NPRM preceding this final rule, the development of the proposed FMVSS No. 213 seat assembly adopted in this final rule changed the agency’s plan. In developing the NPRM, NHTSA tested the HIII-6YO in booster seats and in CRSs with internal harnesses on the proposed standard seat assembly and found that the dummy did not exhibit the high head injury measures and high head acceleration spikes it showed on the current standard seat assembly. Chin-to-chest contact occurred at times, but it was a significantly softer contact than the contacts observed in tests on the current standard seat assembly and would therefore not invalidate the results of the test. On the proposed standard seat assembly, there were no high HIC values and high head acceleration spikes. NHTSA explained that this change is due to the firmer seat cushion on the proposed standard seat assembly that prevents the CRS from bottoming out against the seat frame. The NPRM provided data on dummy readings showing the peak head accelerations curves of the HIII-6YO in tests with the proposed standard seat assembly are lower

in magnitude than in tests with the current standard seat assembly and exhibit no severe head acceleration spikes.¹⁴³

We also proposed to use the HIII-6YO to improve our overall assessment of CRS performance in the FMVSS No. 213 test. The HIII-6YO dummy is more biofidelic than the H2-6YO dummy. The HIII-6YO has been shown to have good kinematics replicating that of a human in slow speed sled testing, exhibiting similar head and pelvis excursion as human children.¹⁴⁴ The agency believed the HIII-6YO would enhance the realism of the standard's frontal impact test in assessing CRS performance, particularly in regard to head injury.¹⁴⁵ While HIC and head excursion measurements were higher, NHTSA did not believe that testing with the HIII-6YO alone would significantly affect the manufacture of current child restraints. In our tests presented in the NPRM with the dummy, all the CRSs tested passed FMVSS No. 213's HIC and excursion limits with the dummy (except for the Evenflo Titan Elite which failed the head excursion limit).¹⁴⁶ Finally, NHTSA proposed to only use the HIII-6YO dummy because replacement parts for the H2-6YO dummy are becoming increasingly more difficult to procure. All test dummies need refurbishment and parts replacement from time to time. As the H2-6YO is not a state-of-the-art dummy, it has become more difficult for NHTSA to obtain replacement parts for the dummy. If parts are unavailable, the utility of the test dummy in NHTSA's compliance test program is significantly diminished.

Comments Received

Several commenters supported the mandatory use of the HIII-6YO dummy in compliance testing. The University of Michigan Transportation Research Institute (UMTRI) supported not further allowing the use of the H2-6YO to test CRSs in the compliance test, as did CR and SRN.

¹⁴³ 85 FR at 69431-69434.

¹⁴⁴ Seacrist, T., et al., "Kinematic Comparison of the Hybrid III and Q-Series Pediatric ATDs to Pediatric Volunteers in Low-Speed Frontal Crashes," 56th Annals of Advances in Automotive Medicine, October 2012.

¹⁴⁵ The HIII-6YO dummy yields a more accurate depiction of the restrained child's head excursion and would help better ensure CRSs are designed to prevent head impacts. The NPRM provided test data showing the HIII-6YO exhibits higher HICs and more head excursion than the older H2-6YO dummy in FMVSS No. 213 booster seat tests. Paired T-tests indicated that the measured differences in HIC and head excursion were significant (p-value <0.01).

¹⁴⁶ See Table 11 of NPRM (85FR69411)

The Automotive Safety Council (suppliers of safety systems to the auto industry) stated that the HIII-6YO dummy still has shortcomings, but use of the HIII-6YO in place of the H2 dummy “is a welcome change as the HIII is a much better ATD in mimicking human movement.”

On the other hand, several manufacturers opposed the proposal. Graco, JPMA, Dorel and Evenflo commented that they believe chin-to-chest contacts have not been resolved. Graco said its testing showed chin-to-chest strikes had occurred in tests of belt-positioning seats “that artificially increase the HIC scores.” Graco argued this “is not representative of a real-world injury mechanism; it is simply an artifact of the neck structure on this dummy.” Graco, JPMA and Dorel referenced NHTSA’s statements in the 2011 final rule that allowed the optional use of the H2-6YO dummy until further notice (76 FR 55826). We stated then that in tests of the dummy on the sled existing at that time: “The HIII–6C dummy has a softer neck than the H2–6YO, which results in slightly greater head excursion results and larger HIC values (chin-to-chest contact) than the H2–6YO. This coupled with the stiff thorax of the HIII–6C dummy, accentuates the HIC values recorded by the dummy.” Graco and Dorel argued it is premature to adopt the HIII-6YO dummy as the upgrades to the dummy discussed in the final rule have not yet been adopted. JPMA and Dorel stated that additional tests are needed to determine whether the proposed standard seat assembly has addressed the limitations of the dummy for all types of CRSs. Evenflo believes that more testing should be done of the HIII-6YO dummy on the proposed standard seat assembly without a tether. It suggests that until such testing confirms the HIII-6YO is appropriate for the seats that are currently on the market, manufacturers should be permitted to have NHTSA use the H2-6YO in compliance tests.

Graco presented data from repeat tests at Calspan with one belt-positioning seat using the HIII-6YO dummy and found, in its opinion, that slight child restraint and dummy pre-test setup variations allowed by the current TP-213 and the NHTSA’s Research Test Procedure cause the head to swing forward and down into the chest plate, generating HIC scores ranging from mid-500s to over 1000. Graco provided the data shown in Table 9.

Table 9. Graco’s Results of HIII-6YO Belt-Positioning Seat Tests on One Model of CRS (Data Provided by Graco)

| Installer | Sled Accel [g] | Sled Velocity [kph] | HIC | Chest resultant [g] | Knee excursion [mm] | Head excursion [mm] |
|------------------|-----------------------|----------------------------|------------|----------------------------|----------------------------|----------------------------|
| 1 | 23.9 | 48.0 | 546 | 56.7 | 564 | 687 |
| 2 | 24.1 | 48.1 | 886 | 56.5 | 574 | 699 |
| 1 | 24.0 | 48.1 | 689 | 58.2 | 472 | 700 |
| 3 | 24.1 | 48.1 | 869 | 52.1 | 564 | 717 |
| 3 | 24.1 | 48.1 | 864 | 52.7 | 577 | 720 |
| 3 | 24.1 | 48.1 | 1020 | 53.7 | 582 | 731 |

Graco said the CV for HIC of this set of tests exceeded 20. Graco believed that “any CV score greater than 10 is generally considered to be a high-variance measurement system in need of improvement.”

Dorel stated that it completed 80 internal research tests using the HIII-6YO dummy with the proposed standard seat assembly. Dorel said the 30 tests it conducted using a CRS with an internal harness showed no concerning performance issues. The remaining 50 tests were completed using the belt-positioning seat mode on 13 existing child restraint platforms (including 3-in-1 convertibles, combination belt-positioning seats and belt-positioning seats with and without backs). Dorel said that 28 of those 50 tests had instances of chin-to-chest contact that Dorel said contributed to elevated HIC scores. The commenter said all 28 of these instances occurred during testing of some 3-in-1, convertible or combination child restraint models. Dorel argued these types of child restraints were not well represented in the NPRM’s belt-positioning seat test data.

Dorel also said it completed 28 follow-up tests using the same 3-in-1 convertibles and combination child restraints with the H2-6YO dummy and the proposed standard seat assembly, to assess whether these elevated HIC36 scores were related to the proposed standard seat assembly or to the HIII-6YO dummy, or a combination. Dorel said its data show that on average the HIC score of the HIII-6YO dummy is 575 points higher than the H2-6YO for the belt-

positioning seat mode in certain 3-in-1 convertible child restraints, and that in certain combination CRS-belt-positioning seat modes, using the HIII-6YO dummy resulted in HIC scores 728 points higher than when the H2-6YO dummy was used.

JPMA and Evenflo stated that the HIII-6YO in an untethered configuration of harnessed CRSs is not well-represented in the test results in the NPRM. Evenflo noted that only three CRSs in this configuration were tested by NHTSA and that some of those CRSs are no longer in the market. Evenflo suggested more testing is necessary to ensure that CRSs which have been in the market for years, particularly larger, taller or all-in-one convertibles, will not be adversely impacted by use of the proposed standard seat assembly and HIII-6YO combination.

Evenflo, Graco, Dorel and JPMA recommended the continued option of testing with the H2-6YO dummy until testing confirms that the changes to the HIII-6YO would not negatively impact the current products, and the HIII-6YO dummy's bio-fidelity regarding chin-to-chest contact has been improved. Graco commented that, as an alternative, NHTSA should provide a methodology for evaluating chin-to-chest strikes to provide relief from HIC36 scores above 1000 that were caused by what the commenter characterized as a non-biofidelic artifact of the test dummy design.

Agency Response

This final rule ends the optional use of the H2-6YO child dummy and adopts the HIII-6YO dummy in FMVSS No. 213 as the sole 6YO child dummy on the compliance date indicated above. We disagree with the objections of the commenters to the HIII dummy's head-to-chest contact. The commenters refer to a statement from a 2011 final rule about the softer neck of the HIII dummy compared to the neck of the H2-6YO dummy, but the statement pertains to tests that were conducted on the current FMVSS No. 213 standard seat assembly. As explained in the NPRM, the current assembly in the standard has a very soft foam that bottoms out¹⁴⁷ against a rigid metal frame in some tests, which contributes to the severe chin-to-chest contact observed

¹⁴⁷ Bottoming out is when a foam lacks support (fully compressed) due to the amount of force being applied to it.

with some CRSs. This severe chin-to-chest contact has been just about eliminated by the stiffer, more representative foam in the updated standard seat assembly. The new foam will not collapse and bottom out like the current standard seat assembly and will reduce or eliminate the abrupt stop of the CRS and dummy at the time the foam is fully compressed, which helps minimize the chin-to-chest contact. While chin-to-chest contact was still observed, it did not result in severe chin-to-chest contact (spikes that are higher than the head acceleration peak before the chin-to-chest contact) that would significantly raise HIC values. While a soft chin-to-chest contact (spikes that are lower than the head acceleration peak before the chin-to-chest contact) might occur within the time of the HIC calculation and may introduce some variability to the HIC value, this contribution is not enough to be the cause of a failure.

Dorel pointed out that the HIII-6YO results in increased HIC values compared to the H2-6YO. The HIII-6YO dummy has a softer neck than the H2-6YO, which results in slightly greater head excursion results and larger HIC values (chin-to-chest contact) than the H2-6YO. The HIII-6YO has been suitable to evaluate many CRS designs in the current standard seat assembly and NHTSA's test data shows that it will continue to be suitable to evaluate CRSs in the updated standard seat assembly, as no severe chin-to-chest contact was found during NHTSA's testing with the updated standard seat assembly. While Graco presented data (see Table 9) where they found a test with severe chin-to-chest contact, NHTSA did not experience severe chin-to-chest contact in its testing. NHTSA believes this is feasible as most CRSs already have responses where they consistently do not show severe chin-to-chest contact when using the HIII-6YO in the current and updated standard seat assembly, although we recognize that some CRSs may need redesigning to meet the updated standard.

In addition, because replacement parts for the H2-6YO are no longer available, the agency (as well as laboratories and industry) eventually won't have the capability of testing with the H2-6YO, and therefore, won't be able to make the annual assessment to ensure the products in the market are compliant with FMVSS No. 213.

NHTSA believes it is time to move solely to the HIII-6YO dummy. We explained in the 2020 NPRM that using up-to-date seat foam on the proposed standard seat assembly would remove the test anomaly that had prevented NHTSA from unreservedly adopting the HIII-6YO into FMVSS No. 213 in the past. The new foam will not collapse and bottom out like the current standard seat assembly and will replicate the performance of the foams in current passenger vehicles. It should be noted that the bottoming out of the old foam happened only infrequently and was not happening to an extent that prevented certification to the HIC requirement. Manufacturers are currently certifying most CRSs to the requirement using the HIII-6YO dummy (using the current standard seat assembly with the softer cushion).¹⁴⁸ The CRSs do not have a problem meeting the standard with the HIII-6YO on the current seat with the soft foam. This is not surprising as NHTSA adopted the HIII-6YO dummy into FMVSS No. 213 twenty years ago (2003) and manufacturers have had since 2003 to optimize their designs to meet child protection requirements using the more advanced HIII-6YO child dummy. The new foam enables use of the advanced dummy in FMVSS No. 213 testing without having to change the dummy's design.

NHTSA believes it is time for *all* CRSs to be assessed with the more advanced HIII-6YO test dummy. The HIII-6YO is superior to the H2-6YO child dummy and provides a better assessment of the protective capabilities of a child restraint system than the H2 dummy. The HIII-6YO dummy is more biofidelic than the H2-6YO dummy. The HIII-6YO has been shown to have good kinematics replicating that of a human in slow speed sled testing, exhibiting similar head and pelvis excursion as human children.¹⁴⁹ Testing CRSs on the updated standard seat assembly in itself would yield dummy kinematics more representative of the kinematics of restrained children in real world frontal crashes than current tests, given the updated standard seat assembly is specially designed to represent a current vehicle rear seat. Having the HIII-6YO

¹⁴⁸ NPRM, 85 FR at 69434, col. 1-2.

¹⁴⁹ Seacrist, T., et al., "Kinematic Comparison of the Hybrid III and Q-Series Pediatric ATDs to Pediatric Volunteers in Low-Speed Frontal Crashes," 56th Annals of Advances in Automotive Medicine, October 2012.

be a part of the test would amplify that realism and assessment. The HIII-6YO also has extended instrumentation capability in many areas over the H2 dummy, such as in the neck and chest. This capability will be advantageous in the event a need should arise to more thoroughly assess the risk of neck and chest injury to children in child restraints. The HIII-6YO has been used in FMVSS No. 208, “Occupant crash protection,” to assess the risk of head, neck and chest injury to out-of-position children by vehicle air bags for decades.

Using the HIII-6YO could particularly improve our assessment of CRS performance in the critical safety area of head injury. NASS-CDS data from 1995-2009 show that 39 percent of AIS 2+ injuries to restrained children in frontal crashes are to the head and face, with 59 percent of these injuries due to contact with the vehicle front seat and back support.¹⁵⁰ Mandatory use of the HIII-6YO in NHTSA’s testing would boost efforts to address the head injury problem. The HIII-6YO dummy yields a more accurate depiction of the restrained child’s head excursion in a crash and would help better ensure CRSs are designed to prevent head impacts in the real world. The softer, more biofidelic neck of the HIII provides a better assessment of a child restraint’s performance in limiting head excursion than the H2. Design changes needed to meet the head excursion limit when tested with the HIII-6YO on the updated seat assembly would be warranted for child safety, as using the HIII-6YO better replicates the kinematics of an actual child than the H2-6YO.

NHTSA is concerned that the optional use of the H2-6YO may take advantage of the dummy’s under-representation of head excursions. NHTSA believes there is a benefit in testing with the HIII-6YO now that the severe-chin-to-chest contact has been addressed, as this dummy more accurately represents the head excursion levels of children. The lead time provided by this final rule will enable CRS designs to be optimized, as necessary, for performance on the updated FMVSS No. 213 standard seat assembly.

¹⁵⁰ In a study of 28 cases of children ages 0 to 15 who sustained AIS 2+ head or face injuries in a frontal crash, researchers found that the front row seat back and the B-pillar were the most commonly contacted components. Arbogast, K. B., S. Wozniak, Locey, C.M., Maltese, M.R., and Zonfrillo, M.R. (2012). Head impact contact points for restrained child occupants. *Traffic Injury Prevention*, **13**(2):172-81.

Evenflo and JPMA believe that in NHTSA's tests supporting the NPRM, CRSs tested without a tether were underrepresented and that more testing should be done to confirm CRS performance would not be negatively affected using the HIII-6YO dummy. Evenflo states that some of the CRSs tested in the NPRM are no longer in the market.

In response, NHTSA disagrees with Evenflo and JPMA about the representation of CRSs without tethers. The NPRM presented data of seven forward-facing CRS models tested in different installation configurations, including five tested using the HIII-6YO and without a tether.¹⁵¹ While some of these models are no longer in the market, that fact is not relevant to the issue at hand, which is that CRSs on the market today are capable of meeting the updated frontal standard with the HIII-6YO dummy and that is evidence that it is practicable. NHTSA's data for the NPRM show only one instance of a CRS not meeting the head excursion requirement, which suggests that some CRSs may need to be reconfigured to meet the updated standard. (The agency considers such a redesign as beneficial to safety, as reduced head excursion would reduce the risk that a child in the CRS would suffer a head injury in a crash.) NHTSA did further testing after the NPRM to evaluate the repeatability and reproducibility (R&R) of tests on the updated standard seat assembly (*supra*). This R&R testing involved testing CRSs multiple times at three different labs with different acceleration pulses. None of the testing showed that there was severe chin-to-chest contact that would contribute to a CRS's failure to meet FMVSS No. 213. In fact, all CRSs tested met the HIC36 requirement. These data indicate that ending the optional use of the H2-6YO dummy would not significantly affect the manufacture of current CRSs.

Graco and Dorel also argue that their tests still showed increased variability in their data due to chin-to-chest contact. Their data do not accord with the data we obtained from an extensive R&R program using three different labs. The agency's data indicate the updated standard seat assembly and test procedures show good repeatability (see section VI.d of this preamble). When analyzing for repeatability and reproducibility, it is difficult to parse out

¹⁵¹ Additional tests of more models and installation configurations were done with other dummies as well.

different possible factors that contribute to variability. Our R&R test series accounted for factors beyond the effect the standard's test procedure and/or standard seat assembly may have on test results. The test series also accounted for elements such as: (1) the variability the test pulse introduces (it is an independent variable that is not part of the system (standard seat assembly, test procedure)); and (2) the variability a CRS itself introduces, as there are some CRSs that are less stable¹⁵² than others when positioned on the standard seat assembly and there are production variabilities among CRSs themselves that can affect the results. Even with those factors contributing to total variability, results from our study showed good R&R. NHTSA's R&R study provides confidence that this final rule's test is repeatable and reproducible with the HIII-6YO dummy. In contrast, it is unknown how closely Graco and Dorel followed the published NPRM test procedure, or which specific test variations were controlled in their testing. The commenters did not indicate (except for 1 test failure Graco pointed out) that the tested CRSs had HIC scores above the standard's performance thresholds or below, which is an issue that bears on the overall context and significance of the test results. Their data does not support a finding that using the HIII-6YO dummy would significantly affect the manufacture of current CRSs. However, to the extent the dummy drives design changes, these changes would be warranted for child safety, as the HIII-6YO replicates the kinematics of an actual child better than the H2-6YO.

Graco argued that its data show that the CV for HIC36 of this set of tests exceeded 20 noting that any CV score greater than 10 is generally considered to be a high-variance measurement system in need of improvement. As discussed in section VI.d. Repeatability and Reproducibility of Test Results, the assessment of repeatability based on CV values was established to assess dummy R&R in qualification tests of crash test dummies. It established CV values less than or equal to 10 percent as acceptable. However, we are applying the same analysis to a much more complex test. Our analysis showed that most of our tests had a CV value

¹⁵² The Graco Affix has a very unstable base that causes shifting and difficulty in positioning it consistently. While we did not see any tests with high HIC36 caused by severe chin-to-chest contact, NHTSA observed higher variability in this CRS. If Graco's data are from this belt positioning booster seat, the movement of the CRS may have contributed to the variability of results.

of less than 10 percent. On the tests where CV values were above 10 percent, it was usually because the HIC values were low (approximately under 500). Therefore, we believe values above 10 percent CV are acceptable. Those values must be put into context of the full results.

NHTSA also disagrees with Graco's suggestion that manufacturers should be provided an option for relief when a HIC36 score is above 1000 due to a chin-to-chest contact. First, chin-to-chest contact can occur in real-world crashes and it is important that child restraint systems control and mitigate the forces exerted on the child, even forces imparted by the child's head hitting against themselves. We are concerned that excluding HIC36 criteria under chin-to-chest contact scenarios may inadvertently encourage CRS designs with significant chin-to-chest contact. An allowance for manufacturers to "exclude" HIC36 evaluation when chin-to-chest contact occurs could also unnecessarily complicate NHTSA enforcement actions, in that a manufacturer may attribute any HIC over 1000 to chin-to-chest whether the failure was caused by such impact or not.

Finally, as explained in the NPRM, NHTSA has decided to move away from the H2-6YO dummy because replacement parts for the dummy are becoming increasingly more difficult for the agency to procure. Although NHTSA's crash test dummies are designed to be durable and capable of withstanding crash testing without unreasonably breaking, all test dummies need refurbishment and parts replacement from time to time. As the H2-6YO is not a state-of-the-art dummy, it has become more difficult for NHTSA to obtain replacement parts for the dummy. The agency is concerned that as parts become harder to obtain, NHTSA's inability to obtain parts will delay and impede its compliance test programs when it must but cannot use the H2 dummy. Ending the optional use of the H2-6YO dummy in compliance testing avoids that potential problem and ensures that NHTSA will be able to assess the compliance of CRSs using the HIII-6YO.

The agency has continued work to develop the Large Omnidirectional Child (LODC) dummy. This dummy represents a 10-year-old child and is designed with increased bio-fidelity,

including a more segmented spine which results in a more biofidelic thoracic motion. However, this dummy is still under development and evaluation. Once a design of this dummy is finished, the agency plans on scaling down the 10-year-old LODC to a 6YO dummy. The agency will then assess the biofidelic capabilities of this future 6-year-old LODC against the HIII-6YO and H2-6YO dummies for potential use in FMVSS No. 213. This work may take several years. Adopting the HIII-6YO child dummy now in FMVSS No. 213 will immediately improve the assessment of crash protection for older children.

e. Positioning the Legs of the HIII-3YO Dummy in CRSs Used Rear-Facing

This final rule adopts the proposed dummy leg positioning procedure that calls for placing the dummy's legs up against the seat back and removing the test dummy's knee joint stops. The procedure will facilitate NHTSA's compliance testing of child restraints that are recommended for use by children in the rear-facing configuration. NHTSA recommends that children 1- to 3-years-old ride rear-facing for as long as possible.¹⁵³ When testing with the 3YO dummy rear-facing, the dummy's legs oftentimes had to be crammed against the updated standard seat assembly's seat back, which NHTSA found problematic. The bracing interaction between the legs of the dummy and the seat back would change the pre-test set recline angle of the rear-facing CRS and the pre-test applied lap belt tension, meaning that it was difficult to keep the recline angle and lap belt tension within specifications in setting the conditions for the dynamic test. To address this problem, the NPRM proposed a dummy leg positioning procedure that calls for placing the dummy's legs up against the seat back and removing the test dummy's knee joint stops to allow the leg to extend at the knee in the test.

Currently, FMVSS No. 213 specifies use of the HIII-3YO child dummy to test CRSs used rear-facing recommended for use by children in the 10 kg to 18.2 kg (22 to 40 lb) weight range. This final rule amends this threshold such that the HIII-3YO child dummy is used only for testing CRSs recommended for children with weights in the 30 to 40 lb range, regardless if the

¹⁵³ <https://www.nhtsa.gov/equipment/car-seats-and-booster-seats#find-the-right-car-seat-car-seat-recommendations>.

CRS is in the forward-facing or rear-facing mode. Notwithstanding this change, the dummy leg positioning procedure continues to be relevant so that the standard is clear about how NHTSA positions the dummy's legs when the CRSs are rear facing. Without the procedure there will be uncertainty about this part of the test, with some testers possibly cramming the dummy's legs against the updated standard seat assembly's seat back.

The leg positioning procedure is based on data analyzing toddler lower extremity postures when seated in CRSs rear-facing. NHTSA initiated a research project conducted by the University of Michigan Transportation Research Institute (UMTRI) to identify toddlers' common lower extremity postures.¹⁵⁴ UMTRI evaluated 29 subjects ages 18- to 36-months in two CRS conditions (wide and narrow seat) used rear-facing.¹⁵⁵ UMTRI took anthropometry measures, surface scans and coordinate measures to evaluate the toddler seating postures. UMTRI found that the most common seating postures for toddlers in rear-facing restraints are with the child's legs bent and "relaxed" with the bottom part of the feet up against the seat back, and with the child's legs spread and "feet flat against each other." These seating positions are not achievable by the HIII-3YO dummy due to the dummy's limited hip range of motion. However, the children also frequently sat with their legs bent and elevated against the vehicle seat back. The HIII-3YO's legs are able to achieve this bent and elevated position. Accordingly, NHTSA proposed to position the HIII-3YO's legs bent and elevated in CRSs used rear-facing as shown by many of the children in the UMTRI study. The procedure is already used by some commercial test labs and CRS manufacturers to test CRSs used rear-facing for older children.

As discussed in the NPRM, as part of the study, UMTRI conducted sled tests to compare the proposed positioning protocol to those used by Transport Canada, various commercial test labs, and CRS manufacturers. The study found no differences in CRS performance using the

¹⁵⁴ "Toddler Lower Extremity Posture in Child Restraint Systems," March 2015, UMTRI-2014-8.

¹⁵⁵ UMTRI also identified the children's common lower extremity postures in forward-facing seats (long and short cushion). Id.

various procedures.¹⁵⁶ NHTSA found also that removing the HIII-3YO knee joint and bending the legs at the knee were easy to do in the lab and added little time to the testing process, unlike some of the other procedures which were more laborious.

Comments Received

Consumer Reports (CR), Volvo, Britax, JPMA and Evenflo commented on this proposal, with CR and Volvo supportive and the other three unsupportive. CR supported the removal of the knee stops for testing with the HIII-3YO in rear-facing child restraints, noting they too remove the knee stops and extend the legs against the back of the seat. CR stated that the dummy's feet are not braced against the seat back and that they found no issues with this methodology.¹⁵⁷ Volvo supported the modification of the knee joints of the dummy, stating that this procedure will accommodate the use of the dummy in rearward-facing CRS when the child restraint system is placed close to the seat back.

Britax did not support the procedure because the commenter did not view a dummy with the knee stops removed as biofidelic. Britax stated that the reports cited in the NPRM supporting this procedure seemed only to analyze repeatability and reproducibility of the summary metrics and did not discuss how test dummy kinematics were affected by the lower leg behavior. Britax stated the knee stop condition may, in some current or future CRS designs, produce dummy-to-dummy or dummy-to-CRS contact, and that it may be appropriate to have a procedure to identify and discount such contact, such as, the commenter said, Canada Motor Vehicle Safety Standard No. 213, section 215(1)(d). This paragraph of CMVSS No. 213 excludes the head acceleration limit for any acceleration caused by another part of the dummy striking its head. Britax said that NHTSA should further investigate and understand how factors such as lateral distance between the feet or dummy footwear can be controlled to help provide a repeatable test method.

¹⁵⁶ "Assessment of ATD Selection and Use for Dynamic Testing of Rear Facing Restraint Systems Designed for Larger Toddlers." UMTRI-2014-12. March 2015.

¹⁵⁷ CR noted, however, that the leg position might prove more challenging when testing higher-weight-capacity infant carriers (recommended for children greater than 13.6 kg (30 pounds)), and rear-facing convertibles that are installed flush against the seat back.

Evenflo recommended against the proposed procedure because, it was concerned that the bending of the legs and removal of knee joints do not comport with actual child positioning in a CRS. Evenflo preferred a test method using more natural leg positioning, with limits in the standard relating to interactions between the lower legs and parts of the CRS. Evenflo believed that NHTSA and Transport Canada should develop and use a single test method, as Evenflo believes that Transport Canada's "removal of dummy leg parts and unnatural positioning create a similar lack of biofidelic integrity." JPMA expressed its belief that NHTSA should specify how injuries that result from contact between various parts of a dummy are evaluated. JPMA also recommended specification of a time window in which injuries and other metrics are evaluated.

Agency Response

NHTSA proposed the dummy leg positioning procedure to enable the use of the dummy in FMVSS No. 213's dynamic test. The dummy is the best available anthropomorphic test device that is representative of children in the 30 to 40 lb range for whom the child restraint is intended. There is a safety need to use the dummy to assess the performance of CRSs in protecting this child occupant group. We realize that removing the knee joint stops results in non-biofidelic knee set-up, but FMVSS No. 213 is not evaluating leg injuries and so the knees do not need to be biofidelic. If the legs do contact the dummy as the legs are swung back towards the dummy's head, this contact is inconsequential as the contact is soft (not injurious and without a significant spike in the acceleration trace) and the interaction happens after HIC36 and chest acceleration are measured. We note that our testing did not show notable differences in the different dummy setups on test results.¹⁵⁸ Testing with an unaltered HIII-3YO dummy is not an option as the bracing interaction between the legs of the dummy and the seat usually changes the pre-test set recline angle of the CRS used rear-facing and the pre-test applied lap belt tension. This bracing

¹⁵⁸ "Assessment of ATD Selection and Use for Dynamic Testing of Rear-facing Restraint Systems Designed for Larger Toddlers." UMTRI-2014-12. March 2015. Docket No. NHTSA-2020-0093-0008 at www.regulations.gov

interaction makes it difficult for the test set up to remain in spec when running the compliance test.

NHTSA will adopt the proposed positioning procedure because the procedure will facilitate compliance testing of the CRSs to the requirements of FMVSS No. 213. The procedure involves removing the dummy's knee joint stops to allow the leg to bend freely at the knee. Removing the knee joint stops results in a seating posture that toddlers adopt in real life. While the legs might sometimes swing back in a non-biofidelic manner, any contact of the legs with the head or torso of the dummy does not affect the injury measures evaluated in FMVSS No. 213. The benefits of testing CRSs rear-facing for older children with the dummy outweighs the unconventional appearance of the knee joints.

Britax and JPMA suggest that NHTSA adopt a procedure to identify and discount leg to head contact. We do not agree with Britax's suggestion to adopt the provision in CMVSS No. 213 215(1)(d), because the foot to head contact experienced in rear-facing tests with the HIII-3YO dummy is very soft and should not prevent HIC36 from being evaluated. NHTSA also believes it would be very difficult to establish objective means to identify and discount the effect the foot contacting the head has on HIC36.

Evenflo commented that having CMVSS and FMVSS harmonized would help the industry lower costs. The U.S. and Canada have historically recognized the benefit of regulatory collaboration in connection with motor vehicle safety, and NHTSA collaborates closely with Transport Canada while developing changes to FMVSS No. 213. As discussed in the NPRM, NHTSA reviewed the provisions in CMVSS No. 213 on this issue and conducted tests using Transport Canada's procedure on testing with the dummy. On this matter, the agency has decided that positioning the HIII-3YO's legs as described in this final rule is the most appropriate approach for FMVSS No. 213.

f. Test Procedure Issues Raised by Commenters

Tensioning Procedures for Seat Belts, Lower Anchor Webbing and Tethers

Evenflo comments that Section 12.D.6.3 of TP-213-10 specifies using a belt-tension gauge to measure seat belt tension, and then to use a load cell to take the final measurement. It states that the test labs do not use a load cell and that the belt tension gauge often cannot be used on LATCH belts because there is not enough space to fit the gauge. Accordingly, the commenter recommends that a load cell be incorporated into the LATCH anchors at a minimum. It notes that for the other installations, a typical belt load cell is acceptable, but NHTSA should specify the model of load cell to be used to ensure consistency among the testing labs.

Graco states that proposed S6.1.2(d)(1)(ii) merely specifies the range of acceptable tension values and directs that a load cell be used without noting a location for the measurement. Graco believes the tether routing on the proposed standard seat assembly does not reflect actual vehicle geometry and materials, particularly the routing of the tether across a steel box beam at the top of the seat back before turning the strap more than 90 degrees to the anchor location, which, Graco states, effectively creates two segments of the tether strap. Graco recommends capturing pre-test tether tension values at the approximate midpoint of the section of the tether between the top of the seat back structure and the “Tether Anchor Assembly.” It states that using this location has proven to result in more consistent readings. Graco also believes that taking the measurement closer to either end of this span results in higher tension values. It further recommends that the appropriate zone in which to place the load cell should be specified in S6.1.2(d). The commenter is concerned that the tether tension may be different between the child restraint seat back and the top of the proposed standard seat assembly, compared to the tension in the segment between the top of the seat back and the tether anchor. It explains that this in turn may result in pre-test under- or overtightening of the tether, which can then lead to inconsistent results for otherwise like-to-like tests. It asks if NHTSA has a study or evidence that the tension in the tether strap between the child restraint seat back and the top of the proposed standard seat assembly is the same as the tension in the segment between the top of the seat back and the tether anchor.

Graco adds that given that the text of S6.1.2(d)(1)(ii) is changing to remove references to certain harness systems, an option should be provided to use a means other than a load cell to capture pre-test belt and tether tension. The commenter states that this would conform S6.1.2(d)(1)(ii) with S6.1.2(d)(1)(iii), which states that, when attaching a child restraint system to the tether anchorage and the lower anchors of the child restraint anchorage system on the standard seat assembly, NHTSA tightens all belt systems used to attach the restraint to the standard seat assembly to a tension of not less than 53.5 N and not more than 67 N, as measured by a load cell or other suitable means used on the webbing portion of the belt. The commenter notes that this suggested change also aligns with Section 12.D.1.2(3) of TP-213-10, which states that seat belt webbing load cells monitor belt preload during CRS installation. Graco adds that this item is not required if an equivalent belt tension measurement device is utilized to determine the preload on the Type 1 and Type 2 seat belt assembly.

Britax commented that when a CRS is installed to the child restraint anchorage system on the standard seat assembly, the current rule specifies that the CRS belt systems are to be adjusted to a tension of 53.5 to 67 N as measured on the webbing portion of the CRS belt. However, Britax states that this procedure does not provide specific guidance for installing a CRS equipped with a rigid lower anchor attachment, which has no webbing. Britax requested the NHTSA consider further guidance in the installation procedure for CRSs with rigid lower anchor attachments.

Agency Response

In general, NHTSA agrees with describing the location and instrumentation for the belt tension measurements but believes that this level of detail would be more appropriate for inclusion in a document such as the OVSC Compliance Test Procedure, which, as previously stated, is a guidance document, and not a rule or regulation. NHTSA will consider adding this information into the updated Compliance Test Procedure as guidance. The advantage of including the information in the Compliance Test Procedure is that the guidance can be tailored

to specific designs of CRS, and the Compliance Test Procedure is also nimbler in terms of updating. The proposed changes did not include the phrase “as measured by a load cell” because the agency wants to give flexibility on how the measurement will be made. While the three-pronged tension gauge is being used now, a better method may arise in the future, and the device can be updated in the Compliance Test Procedure at that time.

Evenflo suggests incorporating a load cell into the LATCH anchors to measure the tension when the three-pronged tension gauge cannot be used with the webbing. (The three-prong tension gauge attaches to free webbing.) NHTSA declines to incorporate the suggested method. Although NHTSA has used load cells in the LATCH anchors in the past, those load cells were used for a different purpose and were rated for much higher loads. Also, NHTSA does not know what variability different load cell models would introduce into the system.

Rather than using a load cell or the three-prong tension gauge, NHTSA is considering a different approach. NHTSA describes in its Research Test Procedure a method it has used to ensure tightness of a CRS to consistent levels when there is insufficient free webbing on which to use the three-prong tension gauge. The method consists of tightening the CRS so that it does not move more than 25 mm (1 inch) in either fore/aft or lateral directions. NHTSA conducted a series of tests with two CRS models comparing the three-pronged gauge to measure the webbing tension and the 1-inch tightness method. Results showed that the two methods had comparable, as well as repeatable, results (Table 10 and Table 11).

NHTSA believes that the 1-inch tightness method is appropriate for installing CRSs when the tension cannot be measured due to a lack of free webbing. NHTSA will consider incorporating this method into its Compliance Test Procedure. In addition, the agency is considering incorporating this alternative tightness method into the regulatory text of FMVSS No. 213 and No. 213b. NHTSA plans to propose incorporating the method in the upcoming NPRM.

Table 10. Comparison of Test Results for Two Tightening Methods - Using HIII-6YO in a Forward-facing Britax Marathon Clicktight and Lower Anchor Installation

| Test Method | Test Number | HIC36 | Chest Acceleration (g) | Head Excursion (mm) | Knee Excursion (mm) |
|---|--------------|-------|------------------------|---------------------|---------------------|
| Calspan 3 Prong Tension Gauge Method | | 652 | 40.6 | 775 | 859 |
| | RR06-19-38 | | | | |
| | RR02-20-01 | 708 | 40.8 | 828 | 880 |
| | RR02-20-02 | 741 | 44.4 | 801 | 869 |
| | St. Dev. | 45.4 | 2.1 | 26.6 | 10.5 |
| | Average | 700.3 | 41.9 | 801.2 | 869.4 |
| | CV% | 6.5 | 5.1 | 3.3 | 1.2 |
| Calspan 1-inch Tightness Method | | 671 | 43.1 | 773 | 834 |
| | RR06-20-35 * | | | | |
| | RR06-20-36 * | 595 | 41.7 | 794 | 846 |
| | RR06-20-37 * | 708 | 44.0 | 794 | 851 |
| | St. Dev. | 57.4 | 1.1 | 11.8 | 9.1 |
| | Average | 658.1 | 42.9 | 787.1 | 843.7 |
| | CV% | 8.7 | 2.7 | 1.5 | 1.1 |
| All | St. Dev. | 51.7 | 1.6 | 20.0 | 16.6 |
| | Average | 679.2 | 42.4 | 794.2 | 856.6 |
| | CV% | 7.6 | 3.8 | 2.5 | 1.9 |

Table 11. Comparison of Test Results for Two Tensioning Methods - Using CRABI-12MO in a Chicco KeyFit Infant CRS and Lower Anchor Installation

| Test Method | Test Number | HIC36 | Chest Acceleration (g) | RF Angle |
|---|--------------|-------|------------------------|----------|
| Calspan 3-Prong Tension Gauge Method | | 380 | 43.9 | 52 |
| | RR06-19-34 | | | |
| | RR06-20-27 | 347 | 43.9 | 50 |
| | RR06-20-28 | 378 | 44.4 | 50 |
| | St. Dev. | 18.7 | 0.3 | 1.2 |
| | Average | 368.1 | 44.1 | 51.0 |
| | CV% | 5.1 | 0.7 | 2.3 |
| Calspan 1-inch Tightness Method | | 391 | 41.6 | 51 |
| | RR06-20-29 * | | | |
| | RR06-20-30 * | 362 | 43.0 | 50 |

| | | | | |
|------------|--------------|-------|------|------|
| | RR06-20-31 * | 386 | 43.8 | 51 |
| | St. Dev. | 15.2 | 1.1 | 0.5 |
| | Average | 379.7 | 42.8 | 51.1 |
| | CV% | 4.0 | 2.7 | 1.1 |
| All | St. Dev. | 16.5 | 1.0 | 0.8 |
| | Average | 373.9 | 43.4 | 51.0 |
| | CV% | 4.4 | 2.4 | 1.6 |

For tether tension, NHTSA installed some CRSs and found cases where the tether tension can be measured consistently on both the area between the CRS and the tether webbing bend to the back of the updated standard seat assembly and between the tether anchorage and the top of the updated standard seat assembly. We also found some models that prevent measuring the tether tension between the CRS and the tether webbing bend to the back of the updated standard seat assembly when the tether is coming from a location lower on the CRS (lower in comparison with other models), and then wrapping around the top of the updated standard seat assembly. In view of these findings, NHTSA will consider including measurement locations in its Compliance Test Procedure. In describing measurement locations, NHTSA will seek to balance the need for flexibility in where the measurement is taken with the desire to provide guidance to NHTSA test laboratories.

In response to Britax's request for guidance on installing CRSs with rigid lower anchorage attachments that have no webbing, NHTSA reviewed the ECE R129 test procedure to evaluate whether updates to the FMVSS No. 213 test procedure are warranted and whether NHTSA should use the ECE R129 test procedure. The ECE R129 test procedure states that a force of 135 ± 15 N shall be applied in a plane parallel to the surface of the standard seat assembly seat cushion. ECE R129 also specifies that the force shall be applied along the center line of the CRS and at a height of no more than 100 mm (3.93 inches) above the standard seat assembly seat cushion. ECE R129 does not specify what instrumentation and what size plate is used to apply the force on the front of the CRS while installing it.

NHTSA conducted three installations of two CRS models with rigid lower anchor attachments (Clek Ozzi and Maxi Cosi Rodifix) generally following the ECE R129 procedure. We used two different methods for applying the force (2X2 inches square plate (“small plate”) and 10X2 inches metal rectangle plate on force gauge “large plate”) to apply the forces in a repeatable and reproducible manner. As noted above, ECE R129 does not have specifications for this aspect of the procedure.

The study indicated that the ECE R129 test procedure does not appear necessary or appropriate for FMVSS No. 213. NHTSA found that the CRSs attached to the lower anchors of the child restraint anchorage system with a force much lower than the 135 N force indicated in ECE R129, which appears to show an absence of a need for a maximum force specification. The agency is also concerned that applying a force such as the one in ECE R129 may result in an installation that positions the CRS too far into the seat back of the standard seat assembly when a retractable rigid attachment is used. In addition, the difference between the maximum forces between the two different models varied more than 20 N, which suggests that each CRS model may have different maximum installation forces based on design (see Table 12).

Table 12. Force Measurements during Rigid Lower Anchorage Attachment Installations on the FMVSS No. 213 Standard Seat Assembly.

| Test No. | Clek Ozzi | | Maxi Cosi Rodifix | |
|----------|-------------|-------------|-------------------|-------------|
| | Small Plate | Large Plate | Small Plate | Large Plate |
| 1 | 30.6 N | 30.2 N | 54 N | 47.6 N |
| 2 | 32.0 N | 29.2 N | 54.6 N | 45 N |
| 3 | 30.6 N | 30.4 N | 51.2 N | 49.2 N |

Because of these design differences, the installation of CRSs with rigid lower anchorage attachments may vary markedly from model to model. Some CRSs not only have rigid lower anchorage attachments but have retracting or foldable rigid lower anchor attachments that may require different installation steps. Currently, NHTSA attaches CRSs to the lower anchors following the manufacturer’s instructions, as some installations may not only require a force to engage the attachments but also to retract the rigid attachment until the CRS is in the

recommended position. The advantage of following the manufacturers' instructions in this situation is the design flexibility provided by this approach. As long as the CRS with rigid lower anchor attachments meets all applicable requirements of FMVSS No. 213 and No. 213b (including S5.9(a) and S5.9(d)), manufacturers may use different designs for the rigid attachments. This approach of following the manufacturer's instructions about attaching a CRSs with rigid lower anchor attachments to the lower anchors is working, so NHTSA does not see a need to change this aspect of FMVSS No. 213 and No. 213b.

Evenflo commented that the dynamic test procedure does not currently provide sufficient direction regarding the order of operations for attaching and tensioning the tether strap, lower LATCH anchors, and the vehicle belts. It argues that not having the order specified introduces inconsistency into the test procedures used by individual labs. It notes that it is very possible to have different outcomes simply because the lab is, for example, completely tensioning the tether before the auto belts or vice versa. Evenflo requests NHTSA to address this ordering of operation in the final rule.

In response, NHTSA disagrees that the order of operations to tension the belts should be specified in the standard. As each CRS is different, it is sometimes necessary for NHTSA to recheck the tensions to ensure they have not changed due to other steps in the procedure (e.g., restraining the dummy in the CRS). NHTSA is evaluating the merits of including a step in the NHTSA Compliance Test Procedure to re-check webbing tensions after dummy installation.

Harness Tension

Several commenters had recommendations about the procedure NHTSA should use for measuring the tension of the internal harness system when preparing a child restraint for testing. Evenflo notes that section 12.D.6.3 of TP-213-10 refers to using a webbing tension pull device placed under each shoulder of the dummy and a waist strap to apply a 9 N force to create a 7 mm (0.27 inch) gap (which correspond to S6.1.2(d)(1-3) in current FMVSS No. 213). Evenflo states this is a challenging, nearly impossible, procedure to execute correctly due to factors such as the

presence of shoulder harness or waist harness covers and blockage created by the headrest. The commenter states that, because of this difficulty, testing labs are instead using a variety of alternative approaches, including a 2-finger method, a pinch test, or a 3-prong belt-tensioning gauge inserted on each shoulder strap between the chest clip and crotch buckle. Evenflo recommends that the belt-tensioning gauge method be added to TP-213 because it is measurable and can be used consistently on any CRSs with any dummy. Evenflo adds that at least one lab targets 4 pounds on the gauge and Evenflo recommends this as well. Graco recommends that NHTSA adopt the pre-test harness tension method using a 3-prong gauge similar to that used by described in VRTC's Research Test Procedure. Graco states it conducted a comparative study using the webbing tension pull device shown in FMVSS No. 213 and a 3-prong gauge like that used by VRTC. The commenter states that test data show use of the 3-prong gauge reduced the CV of head and chest acceleration measures when compared to the current webbing tension pull device. Graco states that the 3-prong gauge is also easier to use when measuring harness tensions.

Agency Response

The current harness tension provision in FMVSS No. 213's test procedures states that if appropriate, shoulder and pelvic belts that directly restrain the dummy shall be adjusted as follows: Tighten the belts until a 9 N force applied (as illustrated in figure 5) to the webbing at the top of each dummy shoulder and to the pelvic webbing 50 mm on either side of the torso midsagittal plane pulls the webbing 7 mm from the dummy. (S6.1.2(d)(1)(i))

During the research conducted for both the update to FMVSS No. 213 and establishment of FMVSS No. 213a, NHTSA used the 3-pronged gauge method to measure tensions in the CRS internal harnesses and found the method practicable and repeatable throughout its testing. NHTSA will consider incorporating the 3-pronged gauge method into NHTSA's Compliance Test Procedure. NHTSA also believes that the specification of the instrumentation should be

made in the Compliance Test Procedure rather than in the regulatory text, as the Compliance Test Procedure can be updated quickly and easily to effectuate any needed change in procedure.

In this final rule, NHTSA is specifying the internal harness tension as “not less than 9 N but not more than 18 N,” which is consistent with FMVSS No. 213a.¹⁵⁹ NHTSA is adopting this amendment because the current regulatory text (“Tighten the belts until a 9 N force applied...pulls the webbing 7 mm from the dummy”) is cumbersome and unnecessary. An upper limit of 18 N, similar to that in FMVSS No. 213a, better ensures consistency in testing. Having a tension range is clearer for the standard and also follows the range format of other tensions specified in the standard.

Correction of TP Figure

Evenflo notes that on Figure 6 on page 34 of the current TP-213-10 is inaccurate because it does not depict the standard’s requirements correctly. NHTSA agrees and has corrected the figure. S5.2.1.1(b) relates to the width of a CRS seat back and provides that for some CRSs, the width may be a specified dimension if the CRS has side supports (side wings) “extending at least 4 inches forward from the padded surface of the portion of the restraint system provided for support of the child’s head.” The side wing depth dimension should be measured from the foremost point of the side wing to the level of the seat back. However, the figure shows the measurement taken at the head center of gravity (CG) plane (see figure below).

¹⁵⁹ In the 2022 final rule establishing FMVSS No. 213a, NHTSA explained that an upper limit for tensioning internal harnesses was specified to have consistency in testing. For the same reason, NHTSA has included an upper limit to this internal harness tension.

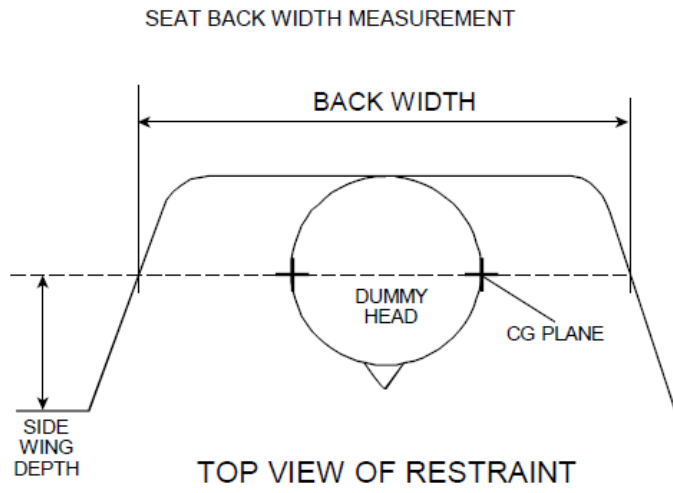

Figure 4. Seat Back Width Measurement (Incorrect Former Figure 6 in TP-213-10)

Although this comment pertains to a figure in the Compliance Test Procedure that was not a direct subject of this rulemaking, the figure is incorrect and can confuse readers. The agency has taken this opportunity to correct the figure as a housekeeping measure. The corrected figure will be included in the next version of the Compliance Test Procedure to show the correct measurement. See corrected figure below.

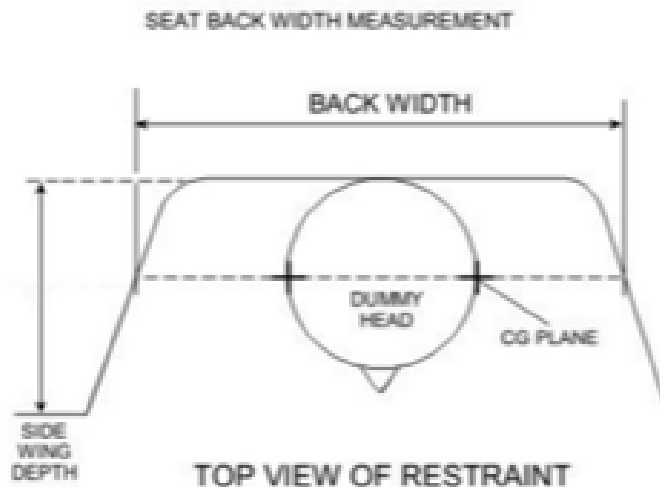

Figure 5. Seat Back Width Measurement Corrected Figure 6 (Test Procedure)

Weighted 6-Year-Old Dummy and Lap Shield

Dorel requests NHTSA to clarify the setup of the weighted HIII-6YO dummy in a forward-facing installation (Section 3.3.1 of the TP) and a belt-positioning booster installation (Section 3.3.2). Dorel asks whether these sections were meant to apply not only to the HIII-6YO dummy but also to the weighted HIII-6YO dummy, particularly in terms of using a lap shield. Dorel points out that currently, there is nothing in the standard or TP 213-10 that describes the installation of the lap shield onto the weighted HIII-6YO dummy when used in the belt-positioning seat mode, even though the lap shield is used with the unweighted version of the dummy.

NHTSA agrees with Dorel that the lap shield should be used with the weighted HIII-6YO. There is a gap between the pelvis and abdomen on the HIII-6YO that a lap belt can get wedged into in a compliance test. The lap shield is used to cover that gap. The lap shield should be used with the weighted HIII-6YO dummy because outwardly the dummy is the same as the unweighted HIII dummy and has the same gap. The lap shield is needed to help ensure the lap belt of the Type 2 belt on the updated standard seat assembly does not wedge into the gap in a compliance test. This final rule will adopt changes to include the use of the lap shield when using the weighted HIII-6YO dummy. The Compliance Test Procedure will also be updated accordingly.

Installation Procedure for CRSs with Unused Support Legs

JPMA, Evenflo and Britax state that NHTSA should specify how unused support legs should be adjusted or positioned during compliance testing to further aid consistency efforts.

In response, NHTSA may not be able to provide a general specification as to how it will position an unused support leg as positioning the leg would depend on the design of the CRS itself. In any event, NHTSA does not see a need to specify how it will position an unused support leg. CRSs with support legs typically have a foldable leg with or without a storage compartment. CRSs with support legs provide instructions in their manuals on using the CRS without the support leg, as sometimes the support leg might cause the CRS to be angled (lifted) when the support leg is not compatible with the vehicle. NHTSA reviewed 13¹⁶⁰ instructions of CRS models with support legs and all of them provide instruction for “folding the support leg” if the support leg cannot be used. For this reason, NHTSA anticipates it will test these CRSs without the support leg by following the instructions of the CRS manufacturer’s printed instructions for storing the leg. NHTSA encourages manufacturers to include as much detail in their instructions necessary for a proper installation of the CRS without the support leg.

¹⁶⁰ Mico XP Max (Maxi Cosi), Pipa Lite (Nuna), PIPA (Nuna), Pipa Lite R (Nuna), Pipa Lite RX (Nuna), Primo Viaggio 435 Nido (Peg Perego), Primo Viaggio 435 Lounge (Peg Perego), SafeMax (Evenflo), Aton 2 (Cybex), Aton M (Cybex), Cloud Q (Cybex), Bugaboo Turtle (Nuna) and Bugaboo Turtle One (Nuna).

Chest Clip Location

Graco suggests NHTSA adopt specifications that focus on the location of the chest clip (sometimes referred to as a “retainer clip”). The commenter states that most, if not all, manufacturers follow the practice of directing caregivers to install the chest clip at armpit level and that this is also the direction provided in the 2020 National Child Passenger Safety Technician Guide. Graco adds that some manufacturers even indicate on their chest clips where the clip should be aligned. Graco states that it typically measures the chest clip location and has found that variation in chest clip placement up or down the torso may have a correlation with injury and excursion values in some circumstances. It also notes that for a crash test dummy the “armpit” is not as well defined as on an infant or toddler, which, Graco states, creates some ambiguity and room for interpretation. Graco recommends that a method be established to ensure greater precision of the chest clip placement.

NHTSA disagrees that more details on positioning the chest clip are needed. NHTSA follows the manufacturer’s instructions to position the chest clip, when a chest clip is provided. The instructions usually state “to position the chest clip at arm pit level.” This is the instruction caregivers follow to use the CRS, so NHTSA’s following the instruction replicates a real-world condition. We believe the CRS’s performance should be assessed when installed in a reasonable manner, including a range of chest clip positions that a caregiver could reasonably understand to be the “arm pit” level. If CRS manufacturers provide, in their instruction manuals, more details on where to place the chest clip, NHTSA will follow these instructions. Commenters did not provide data on how the chest clip placement variation affects injury measures. While this clip placement may introduce variation in injury assessment reference value results, CRS manufacturers should ensure that their CRSs meet the standard when positioned in any area that a caregiver may reasonably interpret as “arm pit level.”

Photographs and Camera Angles

Graco commented that “Pre-test photographs provide a crucial analytical tool for diagnosing a child restraint’s performance, especially when reviewing anomalous test results.” Graco states that pre-test photographs “can be used to assess the initial angle of the [CRS], the angle and placement of the vehicle belt relative to the test article, angle of the dummy head to its torso, placement of the internal harness on the dummy’s shoulders, etc.” Graco recommends that standardized locations for the camera lenses for both still photography and high-speed video cameras be identified in TP-213, with all locations specified in the three coordinates relative to fixed points on the updated standard seat assembly, “similar to what was done by Calspan and VRTC in testing supporting this NPRM.” Graco believes that “This will resolve issues created by parallax differences between images and afford reviewers the ability to more reliably use photogrammetric analytical techniques.”

In response, NHTSA will consider referencing as best practices the camera and photo locations in the agency’s Compliance Test Procedures.

NPRM to Add a Dummy Head Drop Procedure

For purposes of calibrating test dummies for testing, NHTSA has procedures in 49 CFR part 572, “Anthropomorphic test devices,” that specify performance criteria for various parts of the dummy when subjected to various tests. The CRABI-12MO dummy specifications¹⁶¹ include a front and rear head drop test.¹⁶² Graco asked if NHTSA intended to update the HIII-3YO head drop calibration procedure in part 572¹⁶³ to include a rear head drop, or whether the current front-only calibration method would be sufficient for both rear-facing and front-facing dynamic tests with child restraint systems.

NHTSA agrees that there is merit to having a rear head drop test for the HIII-3-year-old dummy. The agency has used the HIII-3YO dummy in research supporting this final rule without a rear head drop procedure and the dummy performed satisfactorily, providing repeatable and

¹⁶¹ 49 CFR part 572, subpart R, sections 572.150-572.155.

¹⁶² 49 CFR 572.152.

¹⁶³ 49 CFR part 572, subpart P.

reproducible results. However, NHTSA has tentatively determined that a rear head drop test would be reasonable since incorporation of the dummy leg positioning procedure discussed above will lead to more regular use of the dummy in tests of CRSs used rear-facing. This issue was not raised in the NPRM though, so NHTSA will not be including a rear head drop test in this final rule. Instead, NHTSA's upcoming NPRM would include a proposal to incorporate a rear head drop test for the HIII-3YO dummy, together with proposed response values for calibrating the response. The proposal is based on the CRABI-12MO dummy rear head drop test procedure. NHTSA plans to move promptly on this upcoming NPRM.

Procedures for 6YO Legs

Britax suggested NHTSA adopt procedures for positioning the HIII-6YO child dummy rear facing. Britax commented that the rear-facing positioning procedure for the HIII-3YO dummy adds clarity to FMVSS No. 213 for CRSs used rear-facing with weight limits up to 18.2 kg (40 lb). The commenter stated that the standard does not provide the same specificity for CRSs labeled for rear-facing use for children over 18.2 kg (40 lb). These child restraints are tested with the HIII-6YO child dummy.

In response, NHTSA does not plan at this time to develop leg positioning procedures for the HIII-6YO tested rear-facing, given the agency's current priorities and demands on its rulemaking resources. According to the 2019 National Survey of the use of Booster Seats¹⁶⁴ there are virtually no children 18.6 to 27.2 kg (41 to 60 lb) in CRSs used rear-facing, and there are only 0.2 percent of children 4- to 6-years-old in CRSs used rear-facing. Thus, it appears that these CRSs are not used rear-facing by children above 18.2 kg (40 lb). That being said, the Safety Act requires manufacturers of restraints recommended for children over 18.2 kg (40 lb) to certify their child restraints meet all applicable FMVSS and are free of safety-related defects at these higher occupant weights. Compliance of child restraints with FMVSS No. 213 is assured

¹⁶⁴ Enriquez, J. (2021, May). *The 2019 national survey of the use of booster seats* (Report No. DOT HS 813 033). National Highway Traffic Safety Administration. Link: <https://crashstats.nhtsa.dot.gov/Api/Public/Publication/813033> [last accessed July 26, 2023]

by this requirement in the Safety Act that manufacturers certify compliance for each child restraint. The agency is able to review the basis for that certification and may conduct testing, with the HIII-6YO in this instance, to assure compliance.

g. Table Summarizing Dummy Selection Criteria

For the convenience of readers, Table 13 below illustrates FMVSS No. 213’s dummy selection criteria as amended by this final rule as discussed above.

As a practical matter, most CRS would be subject to testing using at least two dummies since CRS are usually sold for children of weights spanning more than one weight category. A CRS that is recommended for a weight range that overlaps, in whole or in part, two or more of the weight ranges is subject to testing with the dummies specified for each of those ranges (571.213, S7). For example, a CRS that is recommended for children weighing 5 to 35 pounds will be subject to tests with the newborn, CRABI-12MO, and HIII-3YO dummies. This is also true for CRS that are recommended for height ranges that overlap, in whole or in part, two or more of the height ranges.

Table 13: Summary of this final rule’s decisions about dummy selection criteria

| CRS Recommended For Use by Children of These Weights or Heights-- | Are Compliance Tested by NHTSA With These Dummies (Subparts Refer to 49 CFR Part 572) |
|---|--|
| Weight (W) ≤ 5 kg (11 lb) Height (H) ≤ 650 mm (25.5 inches) | Newborn (subpart K) |
| Weight 5 kg (11 lb) < W ≤ 10 kg (22 lb) Height 650 mm (25.5 inches) < H ≤ 750 mm (29.5 inches) | Newborn (subpart K), CRABI-12MO (subpart R) |
| Weight 10 kg (22 lb) < W ≤ 13.6 kg (30 lb) Height 750 mm (29.5 inches) < H ≤ 870 mm (34.3 inches) | CRABI-12MO (subpart R) (Tested only rear-facing) |
| Weight 13.6 kg (30 lb) < W ≤ 18.2 kg (40 lb) Height 870 mm (34.3 inches) < H ≤ 1100 mm (43.3 inches) | HIII-3YO (subpart P) |

| | |
|--|--|
| Weight 18.2 kg (40 lb) < W ≤ 22.7 kg (50 lb) Height 1100 mm (43.3 inches) < H ≤ 1250 mm (49.2 inches) | HIII-6YO (subpart N) |
| Weight 22.7 kg (50 lb) < W ≤ 29.5 kg (65 lb) Height 1100 mm (43.3 inches) < H ≤ 1250 mm (49.2 inches) | HIII-6YO (subpart N) and weighted HIII-6YO (subpart S) |
| Weight greater than 29.5 kg (65 lb) Height greater than 1250 mm (49.2 inches) | HIII-10YO (subpart T)* |

* HIC is not a pass/fail criterion when testing with the HIII-10YO dummy.

(Note: CRSs with internal harnesses exceeding 29.5 kg (65 lb) with an dummy are not tested with that dummy on the child restraint anchorage system of the updated standard seat assembly.)

X. Add-On School Bus Child Restraint Systems

FMVSS No. 213 has provisions that provide for a type of add-on CRS that is designed for exclusive use on school buses. The CRS is a specially labeled “harness,” which the standard defines in S4 as “a combination pelvic and upper torso child restraint system that consists primarily of flexible material, such as straps, webbing or similar material, and that does not include a rigid seating structure for the child.”¹⁶⁵ FMVSS No. 213 has special accommodations for harnesses manufactured exclusively for use on school bus seats because many school districts and school bus operators need a product with a seat back mount to transport preschoolers, children who need help sitting upright, and children who need to be physically restrained because of physical or behavioral needs.¹⁶⁶ The seat back mount of the specialized harnesses manufactured for use on school bus seats does not use a seat belt to attach to the seat and thus can be used on large school buses without seat belts, which comprise most large school buses. The school bus harnesses are excluded from a general requirement of FMVSS No. 213 that child restraints must be capable of meeting FMVSS No. 213 when attached by a seat belt per S6.1.2(a)(1)(iv)(A), Table 5 to S5.3.2 and Table 3 to S5.1.3.1(a) in FMVSS No. 213b.

NHTSA has become aware of a CRS that is also designed exclusively for school bus use.

The CRS uses a seat back mount to attach to the school bus seat without the use of a seat belt.

¹⁶⁵ Harnesses must meet all applicable requirements of FMVSS No. 213 but harnesses are excluded from several requirements, e.g., they are excluded from having to have attachments that connect to a vehicle’s child restraint anchorage system and from side impact protection requirements.

¹⁶⁶ 69 FR 10928, March 9, 2004.

However, because the CRS is not a harness, it does not qualify as a school bus harness under the wording of the standard and is not permitted under FMVSS No. 213.¹⁶⁷

In the NPRM, NHTSA proposed to amend FMVSS No. 213 to make the standard's definition more design-neutral regarding CRSs that are designed for exclusive use on school bus seats. To permit restraints other than harnesses for exclusive school bus use, NHTSA proposed to add a definition of "school bus child restraint system" in S4 of FMVSS No. 213 that would define the term as a child restraint system (including harnesses), sold for exclusive use on school bus seats, that has a label conforming with S5.3.1(b) of FMVSS No. 213. CRSs without the label in S5.3.1(b) cannot be certified as a school bus CRS. The NPRM also proposed to amend several requirements in the standard to apply them to school bus child restraint systems.

Discussion of Comments and Agency Responses

All commenters responding to this proposal supported the NPRM. The National Association for Pupil Transportation (NAPT), Salem-Keizer Public Schools (Salem-Keizer), IMMI, SRN, and SBS supported the proposed addition of the "school bus child restraint system" to the definition section of FMVSS No. 213, along with the performance standards associated with this new child restraint system classification. Salem-Keizer supported the proposal but suggested a number of miscellaneous changes that were beyond the scope of the rulemaking (some discussed below). IMMI states that the amendment making child restraints for school bus use more design-neutral enables manufacturers to continue development of new products that meet the unique needs of school transportation.¹⁶⁸

¹⁶⁷ NHTSA letter to IMMI, September 21, 2016: <https://isearch.nhtsa.gov/files/14-001678%20IMMI%20STAR%20crs.htm>.

¹⁶⁸ In its comment, IMMI indicates that the amendment would make address some confusion IMMI had in the past as to how products other than harnesses could be produced for school bus use. IMMI states that it had thought that NHTSA had found its school bus product "as an acceptable child restraint for school bus use" and, IMMI believed, had approved it under FMVSS No. 213. NHTSA would like to address a few points to avoid any ongoing confusion. To be clear, NHTSA determined in the past that the STAR is not a harness under FMVSS No. 213 because the device did not meet the definition of "harness" in S4 of the standard. NHTSA would not have approved the STAR for school bus use. NHTSA does not endorse or approve motor vehicles or items of motor vehicle equipment.

SRN supported the proposal, noting that having a separate category will also make it easier to establish when requirements apply to certain types of restraints, e.g., child restraints in passenger vehicles versus school buses. However, SRN and SBS state that child safety restraint systems made for school bus use only are anchored to bus seating by means of a cam wrap (described in the NPRM as “seat back mount or a seat back and seat pan mount attachment method”), which makes them entirely inappropriate for use in other types of vehicles. These commenters state that the products should be labeled clearly for use on school buses only, given the difference in the kinds of vehicle seats on school buses and passenger cars. SRN also suggested improvements to the labeling requirements (some discussed below).

NHTSA has reviewed these comments and has determined that the proposal should be adopted for the reasons stated in the NPRM. The school bus child restraint systems are required to be labeled, as proposed in the NPRM.

Some of the comments that were outside the scope of the rulemaking are described below. Salem-Keizer requested a change to the word “harness,” as, it explained, “harness” promotes a negative connotation to parents when Salem-Keizer discusses using a harness with their child. The commenter said it typically refers to the restraints as a “safety vest.” Salem-Keizer also suggested changing the term of “Child Restraint System” to “Child Safety Restraint System” or “Child Securement System” for the same reason. The commenter also suggested allowing school bus only infant CRSs that would better enable infant restraints to fit in closely spaced school bus seats. SRN urged NHTSA to review and update the current warning label that would be placed on school bus child restraint systems so that the label is more durable, conspicuous, and easier to read. NHTSA appreciates these comments as suggestions for possible future action.

XI. Corrections and Other Minor Amendments

This final rule makes the following corrections and minor amendments to regulatory text. They were proposed in the NPRM except as noted. NHTSA received no comments on the proposed amendments. The corrections in (e) through (g) are simple technical corrections.

a. Corrected Reference

The agency amends S5.5.2(l)(3)(i) of FMVSS No. 213 by correcting a reference to “S5.5.2(l)(3)(A)(i), (ii), or (iii).” The reference is corrected to refer to “S5.5.2(l)(3)(i)(A), (B), or (C).”

b. Section 5.1.2.2, Section 5.4.1.1, and Figure 2

The agency is removing and reserving S5.1.2.2 because it applies to CRSs manufactured before August 1, 2005, and so is no longer relevant. The agency is removing and reserving S5.4.1.1 because it applies to CRSs manufactured before September 2007, and so is no longer relevant. The agency is removing Figure 2 because it applies to CRSs manufactured before August 1, 2005 so is no longer relevant. The agency is renaming Figure 2A in FMVSS No. 213 as Figure 2 in FMVSS No. 213b.

c. Table to S5.1.3.1(a) and Test Configuration II

The agency is correcting the table to S5.1.3.1(a), which specifies performance criteria and test conditions for FMVSS No. 213’s occupant excursion requirements for add-on forward-facing CRSs. When NHTSA created the table, the agency inadvertently did not include a reference to Test Configuration II of FMVSS No. 213. This final rule corrects this oversight.

d. Updating Reference to SAE Recommended Practice J211/1

Current specifications of the test device for built-in child restraints in FMVSS No. 213 (S6.1.1(a)(2)(i)(B) and S6.1.1(a)(2)(ii)(G)) require that instrumentation and data processing be in conformance with SAE Recommended Practice J211 (June 1980), “Instrumentation for Impact Tests.” This final rule updates the reference to SAE Recommended Practice J211/1 (1995).

e. Section S5.9(a)

The first sentence of S5.9(a) states: “Each add-on child restraint *anchorage* system manufactured on or after September 1, 2002, other than a car bed, harness and belt-positioning seat, shall have components permanently attached to the system that enable the restraint to be securely fastened to the lower anchorages of the child restraint anchorage system specified in Standard No. 225...” (emphasis added). It is clear from the context of S5.9(a) and by the final rule adopting S5.9(a) (64 FR 10786, 10816; March 5, 1999), that NHTSA was referring to child restraint systems and not to child restraint anchorage systems. (There are no “add-on” child restraint anchorage systems and car beds, harnesses and belt-positioning seats are not child restraint anchorage systems.) This final rule removes the word “anchorage” to correct this error.

f. Table for S5.3.2

Currently, the Table for S5.3.2 in FMVSS No. 213 shows the required means of installation for different types of add-on child restraint systems. The November 2, 2020 NPRM proposed amending the table to show the incorporation of a Type 2 seat belt installation requirement, among other things. This final rule makes a further change, a housekeeping measure. The table currently shows one column for attachment to the child restraint anchorage system without explicitly showing a provision for tether use if needed, unlike the Type 1 seat belt installation entry that has two columns (showing a Type 1 installation without the tether, and a Type 1 installation with the tether, if needed). We are formatting the Table for S5.3.2 so that it likewise has two similar columns (showing an installation using the lower anchorages of a child restraint anchorage system without the tether, and an installation with the tether, if needed). These installations reflect the dynamic test procedure in S6.1.2 for attachment with the child restraint anchorage system, to show that the procedure involves attachments with and without the tether. This formatting into two columns aligns the table with FMVSS No. 213a, where the installation of the child restraint system is segmented into installation with lower anchorage attachments without the use of a tether, and installation with lower anchorage attachments with

the use of a tether, if needed. These changes to the Table for S5.3.2 relate only to formatting and do not change any current substantive requirement.

g. Tether Tension Range

Currently, FMVSS No. 213 indicates a tension for the tether as not less than 53.5 N and not more than 67 N (S6.1.2(d)(i) and (ii)), which the NPRM had also proposed. During the tests with the updated standard seat assembly, NHTSA found that in some cases the tethers could not be tightened to the proposed tension range because the updated standard seat assembly has a thinner seat back cushion (2 inches) than the current FMVSS No. 213 seat. This final rule adopts a tension range of not less than 45 N and not more than 53.5 N. This lower range in tension values for the tether are based on tether tensions achieved in the tests conducted at VRTC and therefore are practicable. FMVSS No. 213a for side impact protection, which has the same standard seat design, adopted these new tension ranges for tether installations.

h. Clarifying FMVSS No. 213a and the 40 lb Cut Off

On June 30, 2022, NHTSA published a final rule¹⁶⁹ adding FMVSS No. 213a for CRS side impact protection. This new standard applies to “add-on child restraint systems that are either recommended for use by children in a weight range that includes weights up to 18 kg (40 lb) regardless of height, or by children in a height range that includes heights up to 1100 millimeters regardless of weight, except for car beds and harnesses.” NHTSA believes some readers might ask whether “up to 18 kilograms (40 pounds)” and “up to 1100 millimeters” are meant to include 18 kilograms (40 pounds) and 1100 millimeters (43 inches). The answer is no, the “up to” term was not meant to include either 18 kilograms (40 pounds) or 1100 millimeters (43 inches). To make this clearer, the agency plans to clarify the wording of FMVSS No. 213a in the upcoming NPRM. The NPRM would propose to amend FMVSS No. 213a’s “up to” language to instead state: “less than 18 kilograms (40 pounds)” and “less than 1100 millimeters (43

¹⁶⁹ 87 FR 39234.

inches)” so that it is clear that the 18 kg (40 lb) and 1100 mm (43 inches) values are not included in the applicability.¹⁷⁰

XII. Beyond the Scope of the Rulemaking

There were many comments on matters beyond the scope of this rulemaking. NHTSA has discussed a number of these in various parts of this preamble and has noted that the agency is not addressing the matters further in this final rule. The agency will consider the comments as ideas for potential future changes to FMVSS No. 213 and NHTSA child passenger safety programs. In this section, we list some other matters that were raised by commenters, and for some, we offer our observations on the topic. This list is not all-inclusive of the comments that were out of scope of this rulemaking, or the thoughts commenters had on how NHTSA should proceed on various topics.

Retractor

Volvo comments that, when assessing belt-positioning (booster) seat performance, it is important to simulate the function of the vehicle belt retractor in a realistic way. Volvo believes that the operation of the belt retractor is especially important when assessing the belt-positioning seat’s dynamic performance in a crash. Volvo states that the slack (film-spool effect) introduced by the retractor is not present with the fixed attachment that is used in the FMVSS No. 213 current standard seat assembly today. Volvo stated that UMTRI has developed a surrogate retractor and performed a test using the FMVSS No. 213 standard seat assembly and that the test results showed similar kinematics to those achieved with a production seat belt.¹⁷¹ Volvo added

¹⁷⁰ This change would reflect NHTSA’s original intent, as shown in several instances in the June 2022 final rule. See, e.g., 87 FR at 39244, col. 2 (“NHTSA also explained in the NPRM that the FMVSS No. 213a side impact test replicates a near-side crash as experienced by a child under 18.1 kg (40 lb) in a safety seat”); 87 FR 39244, col.3. (“No commenter objected to NHTSA’s requiring manufacturers of booster seats to limit use of boosters to children weighing at least 18.1 kg (40 lb).”)

¹⁷¹ Manary MA, Klinich K, Boyle K, Orton N, Eby B, Weir Q. Development of a surrogate shoulder belt retractor for sled testing of booster seats, *DOT HS 812 660, NHTSA*, Washington, DC, USA, 2019a. Link: https://www.nhtsa.gov/sites/nhtsa.gov/files/documents/812660_development-surrogate-shoulder-belt-retractor-for-sled-testing-of-booster-seats.pdf [last accessed July 26, 2023].

that, UMTRI¹⁷² used the surrogate retractor in a comparative study of belt-positioning seats and concluded that tests with the surrogate retractor were as repeatable as the tests performed with current FMVSS No. 213 conditions. Volvo encouraged NHTSA to include a vehicle retractor function in the FMVSS No. 213 updated standard seat assembly and that this would better represent vehicle crash tests when using the standard seat assembly. SRN also urged NHTSA to consider using a shoulder belt that replicates the spooling effect of a real vehicle seat belt (such as the surrogate belt developed by UMTRI¹⁷³), rather than a fixed belt, to better represent a real crash when performing a FMVSS No. 213 dynamic sled test.

Agency Response

While including a retractor in FMVSS No. 213 to test belt-positioning seats is out of scope of this rulemaking, NHTSA notes here that the agency has been highly interested in including a retractor in the regulation. In fact, NHTSA has funded the research^{174, 175} to which the commenters refer (Volvo and SRN), to develop a surrogate seat belt retractor to achieve a more realistic shoulder belt performance compared to the static (fixed) shoulder belt currently used in FMVSS No. 213. If assessments show the surrogate retractor is suitable for incorporation into NHTSA compliance tests, NHTSA plans to propose adopting it into FMVSS No. 213^{176, 177} in the future.

¹⁷² Klinich KD; Jones MH, Manary MA, Ebert SH, Boyle KJ, Malik L, Orton NR, Reed MP. Investigation of potential design and performance criteria for booster seats through volunteer and dynamic testing. *DOT HS 812 919*. NHTSA, Washington DC, USA, 2020 Link: <https://rosap.nhtsa.gov/view/dot/49119> [last accessed July 26, 2023]

¹⁷³ Klinich KD; Jones MH, Manary MA, Ebert SH, Boyle KJ, Malik L, Orton NR, Reed MP. Investigation of potential design and performance criteria for booster seats through volunteer and dynamic testing. *DOT HS 812 919*. NHTSA, Washington DC, USA, 2020 Link: <https://rosap.nhtsa.gov/view/dot/49119> [last accessed July 26, 2023]

¹⁷⁴ Manary, M. A., Klinich, K. D., Boyle, K. J., Orton, N. R., Eby, B., & Weir, Q. (2016, January) Development of a Surrogate Shoulder Belt Retractor for Sled Testing (Report No. UMTRI-2016-21). Washington, DC: National Highway Traffic Safety Administration. Link: https://www.nhtsa.gov/sites/nhtsa.gov/files/documents/812660_development-surrogate-shoulder-belt-retractor-for-sled-testing-of-booster-seats.pdf [last accessed July 26, 2023]

¹⁷⁵ Klinich KD; Jones MH, Manary MA, Ebert SH, Boyle KJ, Malik L, Orton NR, Reed MP. Investigation of potential design and performance criteria for booster seats through volunteer and dynamic testing. *DOT HS 812 919*. NHTSA, Washington DC, USA, 2020 Link: <https://rosap.nhtsa.gov/view/dot/49119> [last accessed July 26, 2023]

¹⁷⁶ NHTSA has published preliminary drawings of the surrogate retractor which can be found in Docket No. NHTSA-2013-0055-0017.

¹⁷⁷ NHTSA tests using the surrogate retractor can be found in NHTSA's Research Vehicle Test Database at: <https://www.nhtsa.gov/research-data/research-testing-databases#/vehicle>. Test numbers V10063 through V10064 and V10325 through V10339.

Height-Less Devices

Volvo commented that belt-positioning products should not be categorized as belt-positioning (booster) seats or used as child restraints in cars unless they elevate the child and shorten the seat cushion length, better ensuring the child is in an optimal position in a crash and is not slouching. Volvo stated that due to limitations inherent to the standard's seat assembly (replicating the vehicle environment and limitations in dummy sensitivity), some of these devices have passed FMVSS No. 213's dynamic test requirements even though they do not elevate the child or shorten the seat cushion length while seated. Volvo states: “‘Foldable devices’ that do not boost, but have passed FMVSS 213 certification, resulted in submarining¹⁷⁸ when in vehicle crash tests (Tylko et al., 2016).”

Volvo states that a common concern for “height-less booster” types of devices is that they interfere with the seat belt function and do not reposition the child into the seat belt like booster seats do. Volvo states that when used in a crash, height-less devices will straighten the seat belt out between the seat belt anchorage points, resulting in seat belt slack that will influence the kinematics of the child in a crash. If the rerouting is extensive, slack will be introduced as the belt is straightened out, resulting in delayed coupling of the child to the seat belt. The commenter believes that these height-less devices place the lap belt further forward on the thighs, with no direct contact with the pelvis, and that this placement will result in delayed restraint of the pelvis leading to poor kinematics and increased loadings on the child. Volvo is also concerned that a height-less device can result in the child not being restrained over the strong parts of the body, since the child is not raised to the correct position.

Volvo believes height-less devices do not adhere to the protection principles of a CRS and are not booster seats or CRSs. The commenter states that ECE R129 addresses the height of the booster by requiring a certain angle of the lap belt and specifying that the lap belt must pass

¹⁷⁸ Submarining occurs when the pelvis of the occupant slides below the lap belt allowing it to load the abdomen, potentially resulting in internal injuries.

over the top of the thigh, just touching the fold with the pelvis. Volvo suggests that NHTSA add requirements addressing the shortcomings of height-less devices, including requirements for lap belt positioning (that the device must result in the lap belt positioned on top of the thigh and in contact with the pelvis) and for enabling the child to bend their legs (to avoid being out of position in a crash by slouching).

Similarly, CHOP comments that the primary role of a belt-positioning booster seat is to adapt the vehicle seating geometry and restraints, which are designed for adults, to the child. CHOP explained that the nature of a booster seat, which raises the child, is intended to account for both anthropometry and biomechanical differences between children and adults. CHOP states that the boost provided by the structure of the traditional belt-positioning seats is needed for seat belt fit reasons but also to avoid slouching, allowing children to bend their legs over the front edge of the belt-positioning seat. CHOP states that its research using the PIPER¹⁷⁹ pediatric human body model illustrates important differences in kinematics between optimally positioned occupants and those positioned in more naturalistic and realistic postures.^{180, 181} CHOP states it is important to assess, using pediatric human volunteers, how these novel designs influence child posture and not limit assessment only to dummy evaluation in sled/crash tests.

CHOP states that its preliminary work examining the performance of height-less devices revealed important differences between static belt fit and dynamic belt performance. CHOP noted that height-less devices route the belt away from the soft abdomen and the neck similar to traditional belt-positioning seats but do so without the “boost” in an effort to reduce the size and

¹⁷⁹ The PIPER Child model is a finite element model was developed to scale the model for children between at least 1.5 and 6 years of age. It was created as part of the Piper Project Link: <http://piper-project.org/about> (last accessed March 21, 2023)

¹⁸⁰ Maheshwari J, Sarfare S, Falciani C, Belwadi A. Analysis of Kinematic Response of Pediatric Occupants Seated in Naturalistic Positions in Simulated Frontal Small Offset Impacts: With and Without Automatic Emergency Braking. *Stapp Car Crash J.* 2020 Nov;64:31-59. PMID: 3363600. Link to request access: <https://www.proquest.com/docview/2499437312?pq-origsite=gscholar&fromopenview=true> [last accessed July 26, 2023]

¹⁸¹ Maheshwari J, Sarfare S, Falciani C, Belwadi A. Pediatric occupant human body model kinematic and kinetic response variation to changes in seating posture in simulated frontal impacts - with and without automatic emergency braking. *Traffic Inj Prev.* 2020 Oct 23:1-5. doi: 10.1080/15389588.2020.1825699. Epub ahead of print. PMID: 33095067. Link to request access from authors: <https://www.researchgate.net/publication/344843077> [last accessed July 26, 2023]

mass of the product and increase the convenience of the restraint. CHOP explains that both sled tests and computational modeling using the PIPER human body model demonstrated delayed contact between the lap belt and the pelvis due to the fact that the lap belt is positioned far forward on the thighs.¹⁸² CHOP states that by using kinematic rather than kinetic metrics to assess submarining, such as change in torso angle (which is the angle made by shoulder to hip to knee), this research identified differences between the height-less devices and traditional belt-positioning seats that may indicate a potential for suboptimal kinematics that current dummies and FMVSS No. 213 test modes may not be able to reproduce. CHOP believes future research should further develop evaluation metrics that can accurately predict how real children sustain injuries – using advanced technology such as computational human body models “to generate an environment where innovation is encouraged but unintended consequences are avoided.”

Agency Response

While additional requirements for height-less devices and belt-positioning seats are beyond the scope of this rulemaking, NHTSA appreciates the commenters’ views. The agency believes a booster seat’s effectiveness comes from, in part, its ability to elevate a child in a vehicle relative to a vehicle’s lap and shoulder belt to achieve proper belt fit. NHTSA has sponsored a research program¹⁸³ as a first step toward possibly determining a minimum boosting height for CRSs recommended for children weighing more than 18.2 kg (40 lb). The program is evaluating, among other things, the need to specify a minimum boosting height that would provide enough lift to position the child to achieve a beneficial seat belt fit and allow bending of the knees.

¹⁸² Belwadi et al, “Efficiency of booster seat design on the response of the Q6 ATD in stimulated frontal sled impacts” Protection of Children in Cars Conference, Munich, Germany, 2017

¹⁸³ Klinich, K. D., Jones, M. H., Manary, M. A., Ebert, S. H., Boyle, K. J., Malik, L., Reed, M. P. (2020, April). *Investigation of potential design and performance criteria for booster seats through volunteer and dynamic testing* (Report No. DOT HS 812 919). Washington, DC: National Highway Traffic Safety Administration. Link: <https://rosap.nhtl.bts.gov/view/dot/49119> [last accessed July 26, 2023].

A booster seat is a platform used to elevate a child in a vehicle.¹⁸⁴ A belt-positioning seat (which is considered a booster seat in FMVSS No. 213) raises the child above the vehicle seat to better position the seat belts on the child's torso.¹⁸⁵ In the past, NHTSA determined that devices that simply reposition vehicle belts for children, and not reposition the child to fit the belts, are not child restraint systems. In addition, NHTSA has also determined that a product that provides a seating surface for a child meets the definition of a CRS in FMVSS No. 213, but not the definition of a booster seat if it does not position a child to improve belt fit.¹⁸⁶ NHTSA considers the ability of a booster seat to elevate or lift the child to be crucial to occupant protection in side as well as frontal crashes. Lifting the child enables the child to fit the belts and attain the benefits of the belt, stay in-position in a crash as opposed to slouched, and positioned to benefit from other safety systems in the vehicle, such as side curtain air bags installed to meet FMVSS No. 214 ("Side impact protection") and No. 226, "Ejection mitigation." NHTSA considers the boosting ability of a booster seat key to protecting children in side impacts.

NHTSA's research program is therefore also studying the need to specify a minimum booster seat height so that children are positioned high enough to benefit from a vehicle's side curtain air bags. In NHTSA's June 30, 2022, final rule establishing side impact requirements for child restraint systems,¹⁸⁷ NHTSA determined that "When children outgrow their safety seats, they transition to a booster seat, which on average raises a seated child by 82 mm (3.22 inches), which would position the child high enough to benefit from the vehicle's side curtain air bags installed to meet Standards No. 214 and 226." NHTSA is studying all the above issues in the research program. Among other issues, the agency is considering the possibility of a rulemaking to specify a minimum boosting height in FMVSS No. 213 and No. 213b.

Simulated Front Seat Back Interaction

¹⁸⁴ 51 FR 5335, 5337 (February 13, 1986). "Booster seats are designed to be used by older children who have outgrown child seats. By elevating these children, the booster seat allows the child to see out of the vehicle and to use the belt system in the vehicle." Id.

¹⁸⁵ <https://www.nhtsa.gov/interpretations/06-007784as> (Hip Hugger)

¹⁸⁶ <https://www.nhtsa.gov/interpretations/14129ar2jan> (Safesit)

¹⁸⁷ Footnote omitted. 87 FR at 39237.

A few commenters suggested adding a front seat forward of the standard seat assembly. Consumer Reports (CR) argues that data indicate that head contact is a primary source of injury, and therefore NHTSA should represent a front seat back to represent the rear seat environment more accurately. Similarly, SRN and SBS suggest that NHTSA consider adding a front seat structure in a future rulemaking.

Agency Response

We appreciate the information provided in the comments but note that we are not considering rulemaking in this area. Adopting a simulated front seat back into the FMVSS No. 213 frontal test is out of scope of this rulemaking.

We also note that NHTSA is conducting research to address the characteristics of the seat back, head restraints and B-pillar in vehicles^{188, 189} to help reduce head injuries in adults and children. This research aims to develop a repeatable testing method to assess the injury potential from head contact on seat backs and lower B-pillars. Different head forms, locations (seat backs and b-pillar), test speeds (15 mph and 20 mph) and potential countermeasures are being explored. This research will provide more insights into the head to seat back/B-pillar impacts that may help NHTSA isolate the different injury mechanisms contributing to child head injuries against the seat backs and B-pillars.

Include Interpretations in FMVSS No. 213

JPMA and Evenflo encouraged NHTSA to incorporate past interpretations into the standard or into TP-213 as appropriate. In response, NHTSA does not believe it is necessary to incorporate interpretations as a general matter because the interpretations are available on the agency's website and are searchable. Moreover, NHTSA declines to incorporate the

¹⁸⁸ Louden, A., Wietholter, K., Duffy, S.J. "Lower Interior Impacts to Seat Backs and B-Pillars" SAE Government Industry Meeting (2017) Link: <https://www.nhtsa.gov/sites/nhtsa.gov/files/documents/sae2017alouden.pdf> [last accessed July 26, 2023]

¹⁸⁹ Wietholter, K. (2022, July). Development of test procedures for lower interior rear seat occupant protection (Report No. DOT HS 813 319). National Highway Traffic Safety Administration Link: <https://rosap.nhtsa.gov/view/dot/62933> [last accessed May 22, 2023]

interpretations in this final rule because extending the rulemaking to incorporate them would lengthen the time to draft this final rule and increase the volume of the rule's subject matter. Nonetheless, NHTSA appreciates the suggestion and will consider the matter for a possible future action.

Adopting Side Impact Protection

A number of entities (SBS, AAP, CR, the People's Republic of China, Dorel, and CHOP) commented on NHTSA's development of an FMVSS for side impact protection requirements for child restraint systems. The side impact final rule, published on June 30, 2022 (87 FR 39234), adopted a side impact standard seat assembly that is harmonized with the frontal updated standard seat assembly adopted by this final rule.¹⁹⁰ NHTSA finalized the side impact standard seat assembly after considering the comments it received on the 2020 NPRM proposing this frontal updated standard seat assembly. Other side impact issues brought up by the commenters have been addressed in the side impact rule.

Misuse testing

Mr. Jankowiak commented that if "real world" use includes the unintentional misuse of CRSs, FMVSS No. 213 should then encompass this in the compliance testing, if feasible. Mr. Jankowiak explained that because a not insignificant number of CRSs are unintentionally misused or improperly installed, to reflect "real-world use" the tests should include misuse and/or improperly installed CRSs, if feasible.

In response, NHTSA agrees, and FMVSS No. 213 currently includes misuse tests given the degree of misuse in the field. An example is the 32-inch head excursion requirement that CRSs must meet without use of a tether. NHTSA adopted the test based on data showing that most caregivers were not attaching the top tethers of child restraints. Later, NHTSA adopted

¹⁹⁰ Some differences exist between the standard seat assemblies due to the nature of the test. For example, the seat belt and the child restraint anchorage system anchorages are centered in the frontal seat assembly, and aligned 300 mm from the edge of the seat in the side impact seat assembly. The design of the lower anchorages are different but their locations are the same, and some structural reinforcements are different between the standard seat assemblies due to the different loading conditions.

another head excursion test, to supplement the 32-inch test requirement. The supplemental test is a correct use test. It requires child restraints to meet a 28-inch head excursion requirement and in that test, NHTSA will attach a top tether if the child restraint includes one and its written instructions direct consumers to use it.

In addition, FMVSS No. 213 includes a number of requirements to reduce the likelihood of misuse during real-world use. For example, NHTSA has standardized the means of anchoring a child restraint to a vehicle, stating that “standardization of the means of anchoring a child restraint to a vehicle is vital to prevent misuse. By requiring all restraints to be attachable to vehicle seats by the vehicle seat belt, consumers will be assured of a uniform method of attaching the restraint and there will be less confusion regarding that aspect of use.”¹⁹¹

Other Miscellaneous Issues

NHTSA also received comments asking that the agency: take action on fake and counterfeit products in the U.S. market; conduct research to gather more current feedback from parents and child passenger safety technicians on trends and patterns regarding common CRS misuse; ensure that mass media images are screened for technical accuracy; support increased education, public communications, and enforcement efforts regarding the importance of belt-positioning seat use for children through age 12. While such comments are out of scope of the rulemaking, NHTSA appreciates the information provided.

XIII. Child Passenger Safety Issues Arising from Research Findings

In the NPRM, NHTSA requested comment on several developments in child passenger safety observed in the research context that have raised the agency’s concerns. NHTSA requested comments on how best to approach those developments.¹⁹² In this section, we discuss the comments we received and offer some of our current thinking on the topic.

a. CRSs Associated with Submarining or Ejection

¹⁹¹ NPRM, 43 FR 21470, 21472; May 18, 1978.

¹⁹² When NHTSA published the NPRM, the agency docketed a paper in the NPRM docket (Docket No. NHTSA-2020-0093) that discussed the issues in more detail.

NHTSA states in the NPRM that the agency has reviewed research reports on testing done on certain kinds of child restraints that raise concerns about a potential unreasonable risk of submarining¹⁹³ or ejection from the devices in crash scenarios. The CRSs in question are (a) inflatable booster seats, and (b) “shield-type” child restraints (shield-only-CRSs) available in markets overseas.

Inflatable Booster Seats

The NPRM explains that Transport Canada conducted 25-30 mph frontal impact crash tests of different vehicle models, with the HIII-6YO and HIII-10YO dummies restrained using inflatable boosters in rear seats. In the tests, the dummies experienced significant submarining due to excessive compression of the inflatable booster during the crash event. Submarining refers to when the dummy’s pelvis slides under the lap belt and the lap belt directly loads the abdomen. Submarining is a serious safety risk because the lap belt will directly load the occupant’s vulnerable soft organs in the abdomen rather than stay on the strong bones of the pelvis where crash forces can be tolerated better. Booster seats sold in Canada are required to compress by not more than 25 mm (1 inch) when subjected to a 2,250 N quasi-static compression force. Inflatable booster seats cannot currently meet and are unlikely to meet the requirements of this quasi-static compression test and so inflatable booster seats are not sold in Canada. The NPRM requested comment on the findings of the research crash tests conducted in Canada, the booster seat compression test requirements in Canada, and the safety need to have a compression test in FMVSS No. 213.

Comments Received

Various commenters responded to this issue of a compression test for belt-positioning seats. (A belt-positioning seat is a type of booster seat.) The Automotive Safety Council (ASC) commended NHTSA for taking a proactive approach for these CRSs. SBS commented that it has

¹⁹³ “Submarining” refers to the tendency for a restrained occupant to slide forward feet first under the lap belt during a vehicle crash, which could result in serious abdominal, pelvic, and spinal injuries.

limited experience with inflatable boosters “and it was not very positive.” SBS states that it found that inflatable belt-positioning seats led to poor belt fit and poor positioning of the child, “including children slipping off the seat in normal driving.” CR states it has not seen submarining with inflatable belt-positioning seats in its 35 g / 35 mph testing.

Volvo commented in support of a compression test. It states that the dynamic stability of a booster seat is essential as this will influence its performance in a real-world crash. The commenter explains that it compared three different types of backless booster seats having varied degrees of stiffness and design using a human body model¹⁹⁴ and a dummy¹⁹⁵ in a vehicle environment.¹⁹⁶ It states that, although there were similarities in initial belt fit, there were alarming differences in dynamic performance. Specifically, Volvo states that one of the booster seats deformed substantially and this in turn caused unfavorable kinematics and seat belt interaction. Volvo believes that the Transport Canada tests on inflatable boosters referenced in the NPRM¹⁹⁷ that found submarining “highlights the importance of a stable dynamic booster seat design.” Volvo emphasizes that the Transport Canada tests were performed in vehicles “which indicates that the consequences of excessive deformation of the booster is not recognized in the standard seat assembly to the same extent.” It states that, given the differences in the standard seat assembly and vehicle environment and the limitations of the current test dummies and performance criteria to detect submarining and the risk of abdominal injury, Volvo supports the introduction of a quasi-static compression test requirement. The commenter cautioned though, that the test should be written so that the belt-positioning seat would not be sub-optimized for one specific position of the pressure plate. Volvo states it is especially important that “the

¹⁹⁴ Modeling efforts included 18 frontal impact simulations with the finite element PIPER 6-year-old human body model (HBM) investigating different combinations of parameters (booster shape, stiffness, and guiding loop design).

¹⁹⁵ Testing efforts include 3 frontal impact sled tests with a Q10 dummy using vehicle rear seat interiors.

¹⁹⁶ Bohman K, Östh J, Jakobsson L, Stockman I, Wimmerstedt M, Wallin H. Booster cushion design effects on child occupant kinematics and loading assessed using the PIPER 6-year-old HBM and the Q10 ATD in frontal impacts, *Traffic Inj Prev* 20, Aug 2020;1-6 Link for paid access:

<https://www.tandfonline.com/doi/abs/10.1080/15389588.2020.1795148> [last accessed July 26,2023]

¹⁹⁷ Tylko et al., 2016, Docket No. NHTSA-2020-0093-0013

booster seat does not deform excessively on the front edge of the booster as this is the most critical area” to prevent submarining.

BubbleBum, a manufacturer of inflatable belt-positioning seats sold in the U.S., commented against having a compression test in FMVSS No. 213. The manufacturer states that the experimental data from Transport Canada¹⁹⁸ shows that submarining occurs in some but not all tests with inflatable belt-positioning seats. BubbleBum states that Transport Canada 2012¹⁹⁹ test data of 42 full scale rigid barrier frontal vehicle crash tests shows that submarining also occurs in 31 percent of conventional,²⁰⁰ non-inflatable, belt-positioning seats. BubbleBum states that Transport Research Laboratory (TRL)²⁰¹ ²⁰² found that the vast majority of conventional and rigid belt-positioning seats TRL tested exhibited unfavorable kinematics, indicating submarining, in a series of 12 sled tests with 6- and 10-year-old dummies on the seats over a range of different lap belt paths. BubbleBum argues that field observations of conventional belt-positioning seats show that they are extremely effective in mitigating injury as shown in a 2009 Children’s Hospital of Philadelphia study²⁰³ that found children aged 4 to 8 years restrained in belt-positioning seats were 45 percent less likely to sustain injuries than similarly aged children who were using the vehicle seat belt alone. The commenter states that the study also shows that, for backless belt-positioning seats, there was a complete absence of abdominal injuries.

BubbleBum argues that all the findings presented indicate that the experimental observations of belt-positioning seat performance predict there should be substantial abdominal

¹⁹⁸ Referenced in the NPRM and docketed NHTSA-2020-0093-0013 at www.regulations.gov.

¹⁹⁹ Tylko, S. and Bussieres, A. “Responses of the Hybrid III 5th Female and 10-year-old ATD Seated in the Rear Seats of Passenger Vehicles in Frontal Crash Tests” IRCOBI Conference 2012 http://www.ircobi.org/wordpress/downloads/irc12/pdf_files/65.pdf [last accessed July 26, 2023]

²⁰⁰ By conventional belt-positioning seats, NHTSA means belt-positioning seats that have a more rigid seating platform and that are non-inflatable.

²⁰¹ TRL is an accredited Technical Service in the United Kingdom for the type-approval of child restraint systems to UN Regulation No.129.

²⁰² Visvikis, C. Carrol, J. Pitcher, M. and Waagmeester, K. “Assessing Lap Belt Path and Submarining Risk in Booster Seats: Abdominal Pressure Twin Sensors vs. Anterior-superior Iliac Spine Load Cells.” IRCOBI Conference 2018. <http://www.ircobi.org/wordpress/downloads/irc18/pdf-files/92.pdf> [last accessed July 26, 2023]

²⁰³ Arbogast KB, Jermakian JS, Kallan MJ, Durbin DR. Effectiveness of belt-positioning booster seats: an updated assessment. *Pediatrics*. 2009 Nov;124(5):1281-6. doi: 10.1542/peds.2009-0908. Epub 2009 Oct 19. PMID: 19841126. Link for access: <https://publications.aap.org/pediatrics/article-abstract/124/5/1281/72162/Effectiveness-of-Belt-Positioning-Booster-Seats-An?redirectedFrom=fulltext> [last accessed July 26, 2023].

injury in the field, yet such injuries are not observed in the field. The commenter further states that it has conducted extensive crash testing on regulatory standard seat assemblies and real vehicle seats and used conventional belt-positioning seats as controls and found that the 6-year-old dummy did not submerge on the BubbleBum or on the conventional belt-positioning seats. The commenter states that it has 11 years of field experience, with over a million units in the field around the world and 70 percent of these seats in the U.S. and that there are no reported injuries, including submarining injuries, in crashes involving its product. BubbleBum states that its product has been crash tested, approved to the ECE requirements in Europe in the deflated state and tested in the U.S. in a deflated state. It states that its product performs well in the deflated test because it can maintain its structural integrity due to the High-Density Cellular Structure and webbing harness which, the manufacturer states, are integral to the functionality and performance of the seat. The commenter argues that adding compression deflection testing to the regulation would not result in a “measurable benefit” to the health and safety of children.

JPMA commented with its view that research, testing and field performance assessment must clearly demonstrate that addition of a compression test offers real-world injury-reduction benefit given that a compression test would be applied to all belt-positioning seats if incorporated. JPMA said it would similarly like to see clear injury-reduction benefit of rebound control metrics before such an addition is considered, because the depth of the proposed standard seat assembly is 45 mm (1.77 inches) less than the current standard seat assembly and developing and testing rebound control features would be further complicated as a result.

NHTSA’s Views

The agency thanks the commenters for their views on this matter. While NHTSA agrees with BubbleBum that some non-inflatable belt-positioning seats showed submarining during testing and that the BubbleBum did not always submerge in these tests, NHTSA does not agree that this information is a satisfactory answer to the increased risk of submarining that test data are associating with inflatable belt-positioning seats. Some non-inflatable belt-positioning seats

may be prone to submarining for features other than seat stiffness, but several additional studies to the ones noted in the NPRM have also identified a greater risk of submarining associated with inflatable belt-positioning seats.

IIHS and UVA recently conducted a large-scale, parametric study²⁰⁴ of 714 individual belt-positioning seats to examine the link between booster seat designs and child occupant response during simulated collisions. The study used the PIPER human body model, a finite element (FE) model of the FMVSS No. 213 proposed standard seat assembly and characterized key parameters in the belt-positioning seat design space from a sample of 44 physical belt-positioning seats. The findings of the study found inflatable boosters almost always resulted in submarining of the dummy. In NHTSA's view, this recent study, the studies referenced in the NPRM and Volvo's data (see Volvo's comment above) suggest that inflatable belt-positioning seats are posing a greater risk of submarining. NHTSA would like to determine whether such risk is unreasonable.

BubbleBum argues that its product is safe because it meets the performance measures of FMVSS No. 213 while deflated. NHTSA is not persuaded, as a deflated device is akin to a "height-less" device. The risk of submarining is real with height-less devices, but difficult to detect because the child dummy pelvis joint does not have the flexibility of a human child pelvic joint. A human child can bend its lower back and pelvis into a slouched position allowing the seat belt to ride up the abdomen of the child (as the child submarines). In contrast, the dummy's lower back and pelvis cannot bend as much as a human (i.e., bend into a slouching position), which reduces the chances of the seat belt moving upwards towards the abdomen when the dummy is seated. In addition, FMVSS No. 213's test uses a locked (fixed) Type 2 seat belt that does not allow seat belt spool out (contrary to the retractors in an actual vehicle), which prevents the dummy from having a more forward movement in the dynamic event. Submarining can occur

²⁰⁴ Parametric study of booster seat design characteristics Jason Forman, Matthew Miller, Daniel Perez-Rapela, Bronislaw Gepner, University of Virginia, Center for Applied Biomechanics; Marcy Edwards, Jessica Jermakian, Insurance Institute for Highway Safety (US). Link: <https://www.iihs.org/topics/bibliography/ref/2245> [last accessed July 26, 2023]

as the child pelvis slips under the lap belt, loading the abdomen. This means that the locked retractor is helping overcome the submarining that would occur had the event been in a real vehicle with an actual retractor. The locked retractor leads to unrealistically favorable results in terms of submarining. Similarly, the locked retractor may enable a dummy to exhibit head and knee excursions within FMVSS No. 213's limits when sitting on the standard seat assembly without a CRS-- even when the limits may be grossly exceeded in a test of the dummy in a real vehicle with an actual retractor. This results in an analysis of a restraint that is more favorable than it would likely be in a real-world crash. As noted in the section above, NHTSA is working to add a retractor to FMVSS No. 213 that is not locked.

JPMA commented that because the depth of the proposed standard seat assembly is 45 mm (1.77 inches) less than the current standard seat assembly, developing and testing rebound control features would be further complicated. NHTSA understands that by "depth" JPMA is referring to the thickness of the seat foam. We disagree that a thinner seat foam in the updated standard seat assembly would complicate booster seat rebound control features. Testing with the updated standard seat assembly showed that current belt-positioning seat designs already meet the updates to the standard, therefore, there will be no need to develop new rebound control features. JPMA did not provide any evidence on how the thinner foam would impact belt-positioning seat designs.

NHTSA conducted compression tests²⁰⁵ on 14 CRS models²⁰⁶ spanning the different materials observed in the market (Table 14). Test results showed that BubbleBum and Hiccapop (both inflatable belt-positioning seats) were the only belt-positioning seats that failed the compression tests with deflections reaching 42.56 and 49.4 mm (1.67 and 1.94 inches) respectively. The Clek Ozzi belt positioning seat made of EPS foam almost reached the 25 mm

²⁰⁵ Following CMVSS Test Method 213.2 Section 4 which specifies using a 203 mm diameter flat plate to apply a vertical force at a rate between 50 to 500 mm/min. An initial preload of 175N (~40lbs) is applied followed by a 2250N (~500 lbs.) load while measuring the deflection when fully loaded. Booster seat must deflect less than 25 mm.

²⁰⁶ The Mifold was also tested but was excluded from this data as it was not determined whether the Mifold was a belt-positioning seat.

(1 inch) deflection limit. The data indicate that all non-inflatable belt-positioning seats would meet the compression test, and test results with the updated standard seat assembly show that belt-positioning seats also meet the performance requirements. Therefore, most non-inflatable belt-positioning seats would not need redesigning if a compression test were adopted into FMVSS No. 213.

Table 14. Belt-positioning Seat Tested for Compression with Manufacturing/Material Details. (NHTSA test results)

| Manufacturer | Model | Seat Categories | Deflection (mm) |
|---------------------|---|------------------------|------------------------|
| Evenflo | AMP Backless Booster | Injection molded | 8.39 |
| KidsEmbrace | Batman Backless Booster | Blow molded | 10.351 |
| Graco | Turbo GO Folding Backless Booster | Injection molded | 10.691 |
| Graco | Backless TurboBooster | Injection molded | 11.685 |
| Lil Fan | Slimline No Back Seat Booster | Blow molded | 12.654 |
| Cosco | Topside Backless Booster | Blow molded | 12.809 |
| Safety 1st | Incognito | EPP Foam | 13.717 |
| Graco | TurboBooster TakeAlong Backless Booster | Injection molded | 14.347 |
| Safe Traffic System | JD16100BKR-1 Delighter Booster | EPP Foam | 17.53 |
| Chicco | Booster | Injection molded | 17.968 |
| Harmony | Juvenile Youth Backless Booster | Blow molded | 19.054 |
| Clek | Ozzi Booster | EPP Foam | 24.234 |
| Bubble Bum | Backless Booster | Inflatable | 42.496 |
| Hiccapop | Uberboost Inflatable Booster | Inflatable | 49.427 |

JPMA believes that a compression limit should only be implemented if a measurable benefit can be determined. In response, the Safety Act authorizes NHTSA to issue safety standards to protect the public against unreasonable risk of accidents occurring and against unreasonable risk of death or injury in an accident. If the commenter is saying that NHTSA must

identify injuries found in the field, that is an incorrect understanding of the Safety Act. NHTSA can move to issue FMVSS requirements based on research data alone, without waiting for an associated injury to be found in the field. BubbleBum argues that the absence of reported injuries in the field is evidence of the safety of their product. In response, reported injuries in the field may not reflect the extent of injuries in the field or the likelihood that such injuries may occur. Data are also sparse overall on injuries that may affect only two products in the market, so if injuries were occurring or being made more severe in the field due to an inflatable booster compressing in a crash, it is unlikely information about such injuries could be easily found. NHTSA believes the research data showing an increased risk of injury due to the product compressing in a crash is sufficiently concerning to warrant further exploration.

In response to BubbleBum's argument that a study showed that belt-positioning seats have proven to be highly effective in preventing injuries in the field, these data relate to conventional booster seats that do not compress in a crash. The booster seats in the study have a similar construction amongst them and are different from inflatable devices. The effectiveness findings for these boosters cannot be applied to a product that does not keep the child boosted (and protected against submarining) throughout the crash event.

NHTSA plans to continue to look at inflatable belt-positioning seats. The Automotive Safety Council, SBS and Volvo supported actions to address the potential increased risk to safety of inflatable designs. NHTSA is working to develop a surrogate retractor, and additional belt-positioning seat performance measures,²⁰⁷ that may help detect submarining in belt-positioning seats by allowing some spool out of the seat belt webbing before locking, thus replicating the retractors in actual vehicles. When the work is complete, NHTSA will consider the merits of rulemaking to incorporate the surrogate retractor and additional belt-positioning seat

²⁰⁷ Klinich, K. D., Jones, M. H., Manary, M. A., Ebert, S. H., Boyle, K. J., Malik, L., ... Reed, M. P. (2020, April). *Investigation of potential design and performance criteria for booster seats through volunteer and dynamic testing* (Report No. DOT HS 812 919). Washington, DC: National Highway Traffic Safety Administration. Link: https://rosap.nhtsa.gov/view/dot/49119/dot_49119_DS1.pdf [last accessed July 26, 2023].

performance requirements into FMVSS No. 213. The agency envisions that the future rulemaking could include other approaches that address height-less devices as well.

Shield-Only-CRSs

Shield-only-CRSs only have a shield to restrain a young child's upper torso, lower torso, and crotch. While such CRSs are currently not available in the U.S., there are a wide variety of shield-only-CRSs in Europe intended for children weighing less than 13.6 kg (30 lb). Child dummies (representing children aged 18-months old and 3-years-old) restrained in shield-only-CRSs in simulated vehicle rollover tests, 64 km/h (40 mph) offset frontal impact vehicle crash tests, and in 64 km/h (40 mph) Allgemeiner Deutscher Automobil-Club (ADAC) type frontal impact sled tests were completely or partially ejected from the child restraints. The test results raise concern about the ability of a shield-only-CRS to retain small children in the CRS in certain crashes or in a rollover. The NPRM sought comment on the findings of these research tests. The agency asked if FMVSS No. 213 should require shield-only-CRSs to have additional shoulder belts and a crotch strap, similar to the requirements for child restraints that have belts designed to restrain the child (S5.4.3.3).

Comments Received

NHTSA received comments providing perspectives from very different points of view. Cybex provided historical information relating to the research studies discussed in the NPRM to imply that current shield child restraint systems would not exhibit the performance found in the above tests. Cybex states that the European child restraint system overturning test was amended in UN Regulation No. 44 in February 2014 to be more stringent, in part to address the performance of shield systems in vehicle rollover tests. The improved overturning test procedure was also introduced in the new UN Regulation No. 129 for child restraints that entered into force on June 10, 2014. Cybex states that all shield systems type-approved after the aforementioned dates meet the improved overturning requirements, while "the shield systems that were used by Tylko would not have been subject to these more stringent overturning requirements." Cybex

also believes that shield systems used in a study by TRL²⁰⁸ under contract to Britax were likely approved prior to the amendment made to the overturning test. Cybex states that UN R.129 is now the primary child restraint system regulation in those parts of the world that follow UN Regulations. The commenter believes that requirements in R.129 would prevent a shield system that allows the partial ejection described in the TRL study from gaining type-approval. The commenter suggests that NHTSA “consider adopting performance-based requirements instead of specifying design constraints (e.g., minimum radius, curvature of contactable surface, shoulder straps).”

Volvo commented that shield-only CRSs should not be used as they do not restrain a child according to fundamental principles of protection. The commenter explains that the fundamental principles include an early coupling between the occupant and the restraint, which leads to reduced loading on the child. Volvo states that a misuse study shows that shields are not fastened tight enough to the child’s body, likely for the child’s comfort. Volvo believes a shield-only child restraint inherently is likely to have a higher risk of slack as compared to a child restraint with a harness. “A harness is needed to restrain the child over the strong parts of the body and to ensure that the child will not be ejected from the restraint.”²⁰⁹ Volvo states that crash testing,^{210, 211} field studies,²¹² and misuse observation²¹³ studies all provide evidence that shield-

²⁰⁸ Visvikis, C., et al., “Evaluation of shield and harness systems in frontal impact sled experiments,” TRL, UK. Johannsen, H., Beillas, P., Lesire, P. “Analysis of the performance of different architectures of forward-facing CRSs with integral restraint system,” International Technical Conference on the Enhanced Safety of Vehicles Conference, Seoul, Republic of Korea, 2013, Paper 13-0226.

²⁰⁹ Kent R, Forman J. Restraint biomechanics, In: Yoganandan N. Accidental Injury, Springer, 2015:116-8

²¹⁰ Johannsen H, Beillas P, Lesire P. Analysis of the performance of different architectures of forward-facing CRS with integral restraint systems, 23rd Int. ESV Conf., Paper No. 13-0226, Seoul, Korea, 2013 Link: <https://www-esv.nhtsa.dot.gov/Proceedings/23/files/Session%205%20Oral.pdf> [last accessed July 26, 2023]

²¹¹ Tylko S, Bussiere A, Lepretre JP. Comparison of HIII and Q series child ATDs for the evaluation of child restraint performance during dynamic rollover, 12th Int. Conf. Protection of Children in Cars, Munich, Germany, 2013.

²¹² Edgerton, Orzechowski KM, Eichelberger MR. Not all child safety seats are created equal: the potential dangers of shield booster seats, Pediatrics 113(3), 2004:153-158 Link: https://www.researchgate.net/publication/5855078_Not_All_Child_Safety_Seats_Are_Created_Equal_The_Potential_Dangers_of_Shield_Booster_Seats [last accessed July 26, 2023]

²¹³ Morris SD, Arbogast KB, Durbin DR, Winston FK, Misuse of booster seats, Inj Prevention 6(4), 2000:281-4 Link: <https://injuryprevention.bmj.com/content/injuryprev/6/4/281.full.pdf> [last accessed: July 26, 2023].

only CRS do not address the fundamental principles of protection and result in reduced occupant protection.

Volvo did not support the idea of requiring the shield-only CRSs to have shoulder belts and a crotch strap. The commenter states that an internal harness is needed to ensure that the strong body parts are engaged and to ensure early coupling with the child occupant, thus reducing the risk of ejection. Volvo believes that once the harness has been added to the child seat, the shield can be completely removed. Volvo states that adding the belts and strap may increase the risk of misuse as well as have a negative impact on ease-of-use.

Consumer Reports states that as there are not currently any shield-only child restraints in the U.S., preventing their use would presumably be more cost effective than the research and development needed to determine how to regulate them best.

NHTSA's Views

The agency appreciates the information from these commenters. NHTSA will consider them as it contemplates possible future actions the agency should take to address shield-only child restraints.

b. Should Infant Carriers' Height Limits Better Align with Their Weight Limits?

NHTSA requested information on a matter showing up in the field concerning children under 1YO outgrowing infant carriers by height much earlier than by weight. Research studies conducted at UMTRI²¹⁴ show that some infant carriers marketed as suitable for children up to 13.6 kg (30 lb) cannot “fit” the height of a 95th percentile 1 YO or an average 1.5 YO.²¹⁵

NHTSA stated that the agency believes that infant carriers' height and weight recommendations should better match the children for whom the CRS is recommended. NHTSA requested comment on UMTRI's research findings. The NPRM asked: Should infant carriers' height and

²¹⁴ Manary, M., et al., “Comparing the CRABI-12 and CRABI-18 for Infant Child Restraint System Evaluation.” June 2015. DOT HS 812 156. The report is available in the docket for this NPRM.

²¹⁵ Field experience indicates that children at the higher end of growth charts typically outgrow the carriers by height at around 9-10 months.

weight recommendations better match up to better accommodate the children for whom the CRS is recommended?

Comments Received

NHTSA received a number of views on this issue.

Evenflo states that individual manufacturers have historically determined whether their products can accommodate children recommended for their seats who fall within the height and weight limits and that research referenced in the NPRM confirms there are no uniform practices for child sizes that are being used by manufacturers for determining proper heights and weights for infant CRSs. Evenflo and Cybex refer to the UN child restraint regulation (UN R.129). Evenflo states that R.129 “deals with this issue directly by specifying the child size data which must be used to classify child restraints.” Cybex also references the Australia and New Zealand child restraint standard (AS/NZ 1754) which establishes critical dimensions for all manufacturers to use in the design and development of CRSs and belt-positioning seats. Evenflo and Cybex note that adopting the approach of these regulations would be a way to establish height and weight ranges for CRSs that can be applied consistently from manufacturer to manufacturer.

JPMA states it is open to the concept of aligning interior child restraint dimensions with child stature, and that it has seen similar concepts reflected in other regulations. While the commenter did not name the regulations, NHTSA assumes JPMA is referring to the UN and AS/NZ standards.

Consumer Reports (CR) supports that height limits should more accurately match rear-facing-only infant seat weight limits to reflect real children. CR explained that higher weight limits should not be used as a marketing tool without an appropriate accompanying height limit (e.g., a 13.6 kg (30-pound) CRS should not have a 29-inch height limit).

CR believes that NHTSA is missing an opportunity to address the current disconnect in the weight and height limits of rear-facing-only infant seats. CR explains that current rear-facing-only infant seats have weight maximums that are not commensurate with the seat’s shell height

or height limitations. CR states that of the 36 infant seats currently in CR's ratings, 33 have maximum weight limits of between 13.6 kg (30 lb) and 15.8 kg (35 lb) but have height limits between 762 to 812 mm (30 and 32 inches). CR comments that, based on CDC growth charts, the combination of the lowest weight limit for that group (13.6 kg (30-pound)) with the highest height limit (812 mm (32 inches)): a 15.8-kg (35-pound) child is approximately a 95th percentile 28-month-old, whose height would be between 889 to 1016 mm (35 to 40 inches). CR adds that of the 66 infant seats in the market, only three have a 889-mm (35-inch) height limit and 46 out of 66 infant seats listed there have a 15.8-kg (35-pound) limit. CR opined that this practice potentially results in misuse for kids remaining in their rear-facing infant carrier after they have exceeded the height limitations. CR recommends that NHTSA should set standards prohibiting manufacturers from having weight and height allowances that are so disparate.

Volvo states that it is essential to ensure that the optimal CRS is used for the child (age and size) and that the child must fit in the infant CRS, for it to provide good protection. Volvo supports NHTSA's view that infant CRS height and weight recommendations should better align with the children for whom the CRS is recommended. Volvo states that the UMTRI study shows that infant CRSs vary in size, so it is essential that customers are provided clear and relevant information on what size child the CRS is designed for. Volvo believes that an appropriate clearance between the top of the head and the top of the CRS shell is essential because in the real-world environment, there is likely a vehicle seat in front posing a risk of head impacts if the head is positioned too close. Volvo notes that it encourages transfer to a larger CRS that can be used rearward-facing as soon as the infant is not carried easily in the infant CRS.

SRN disagrees that weight limits of CRSs should better match the height limits. SRN states that, having experienced when rear-facing weight limits were inadequate to keep even many 1-year-old rear-facing, "we appreciate the buffer that today's models provide." (NHTSA understands this to mean SRN appreciates the higher weight limits of the infant carriers sold today even if a child may outgrow an infant seat by height before reaching the weight limit of the

CRS, because the higher limits result in more children riding rear facing.) SRN states that since the height limit is constrained by the fore-aft space in vehicles, any alignment in height and weight limits would involve lowering the rear-facing weight limits. SRN states, “This is not a direction we want to go, especially given that many state laws now specify a child age limit for RF assuming the ample weight limits provided by today’s CRSs, even for the heaviest children.” SRN states it would be better to see a greater emphasis on the instructions for height limits, especially the application of a required rear-facing height maximum indicator directly on the front of the CRS.

Graco does not address the specific question NHTSA posed about infant seats. Instead, the commenter discusses FMVSS No. 213’s seat back height requirements generally and Graco’s ideas for amending the standard relating to child restraints that have adjustable-height seat backs that “grow with the child.”

NHTSA’s Views

NHTSA is aware of the approach of UN R.129 and AS/NZ 1754 and is considering the benefits and challenges of such an approach. We believe that some of the changes in this final rule will address this issue to an extent. For example, infant carriers will most likely be marketed for children up to 13.6 kg (30 lb) and not heavier children. As a result, there will be many fewer infant carriers (if at all) in the future where children will outgrow them by height before reaching the weight threshold. If a manufacturer decides to recommend an infant carrier for children over 13.6 kg (30 lb), then that CRS will be subject to testing using the 3-year-old dummy as well and will need to be large enough to accommodate the dummy. All matters raised by the commenters will be considered by NHTSA as the agency decides whether and how to address this matter in the future.

c. Virtual Models for CRS Fit

NHTSA has supported the development of computer models of children of different weights and heights to assist CRS manufacturers in designing child restraints that better fit the

children for whom the CRS is recommended.²¹⁶ These virtual models are available to the public to improve the fit of CRSs to children.²¹⁷ NHTSA requested comments from manufacturers and other parties on whether they use the models and whether the models are helpful.

NHTSA received several comments providing feedback on the models. Britax identified what it called a few key areas for future development that the commenter believes would further increase the utility of the virtual models for CRS fit. Britax suggests the following additions to the model: (i) the expansion of the covered age range through infancy, and (ii) the ability to articulate the toddler model, especially flexion angle at the hip and flexion/extension of the torso and neck. Similarly, Cybex, Evenflo, and Volvo state that the models would be more useful if they could be manipulated into more natural positions or adjusted at major points. Volvo encourages further developments, including features making it possible to change the posture of the models to fit the specific CRS or vehicle seats. Evenflo states that virtual fit checks of the mannequins in car seats would be possible.

Graco states that it has not used NHTSA's virtual child models and is unlikely to do so in the future as they are provided in STL format and are not particularly suitable for manipulation (such as changing the seating posture or reorienting the arms relative to the torso) in the computer aided design software used by Graco. Graco suggests that NHTSA might consider making the models available in a data format that can be more readily integrated into users' computer aided modeling tools, such as Parasolid or STEP.

NHTSA's Response

NHTSA appreciates the suggestions for improving the models. The agency will consider improving the virtual models so that they provide more functionality, such as with moving joints to better position the virtual models, and so they can be used in a more accessible data format.

²¹⁶ NHTSA has sponsored an UMTRI project developing toddler virtual dummies for use in improving of the fit of CRSs to child passengers. Information on a 2015 UMTRI workshop describing development of the toddler virtual fit dummies can be found at: <http://umtri.umich.edu/our-results/projects/umtri-workshop-new-tools-child-occupant-protection>.

²¹⁷ Toddler virtual models available for download at: <http://childshape.org/toddler/manikins/>.

XIV. Lead Time and Compliance Dates

The NPRM proposed that the compliance date for most of the amendments in the rulemaking action would be three years following the date of publication of the final rule in the **Federal Register**, with optional early compliance permitted, except as follows:

- A 180-day compliance date was proposed for the changes to registration card requirements and the proposed changes to permit more add-on school bus child restraint systems (early optional compliance would be permitted for both); and,
- A 1-year compliance date was proposed for labeling and printed instructions requirement changes (early optional compliance would be permitted).

Comments Received

All comments on this issue supported the proposed lead times and compliance dates. JPMA supported the proposed option for early compliance “so CRS model designs can be optimized to comply with one set of test configurations, rather than two.” The commenter also added that the lead time for labeling and printed instructions changes should provide time to allow manufacturers to use current labels for a period so “existing supplies can be exhausted and production processes are minimally interrupted by the changes.”

Dorel, Evenflo, and, IMMI also supported the proposed option for early compliance. Dorel stated that labeling, registration and dummy compliance testing in the NPRM could be brought to a final rule quickly as these were “not controversial.” Evenflo asked whether the labeling changes that must be implemented by the end of the one-year lead time and the testing changes that must be implemented by the end of 3 years will require two labeling updates, which, Evenflo stated, seems inefficient and potentially confusing to the consumer. Graco recommended that the effective dates of both the revised frontal and the new side impact coincide. Graco suggested that all proposed changes affecting labels become mandatory concurrently, except for S5.5.2(f) where Graco suggested that manufacturers should have the option of adopting this section upon issuance of the final rule or a short time thereafter.

Agency Response

This final rule adopts the compliance dates proposed in the NPRM except to provide 1 year for the changes to school bus CRS, labeling, and registration card changes. The change is made to align with the requirements for the labeling and printed instructions changes, to reduce the need for manufacturers having to deal with multiple compliance dates within the standard. We note that there is minimal or no practical consequence to providing a year for the changes rather than 180 days. The amendments pertaining to the school bus CRS and registration program are permissive and do not require manufacturers to change any of their current practices. Further, voluntary early compliance is permitted, so manufacturers can implement the changes as soon as they want. NHTSA does not believe having the labeling changes with an earlier compliance date than the new testing requirements would be inefficient as early compliance is an option and manufacturers could accommodate early compliance if they so choose. NHTSA's data show that current CRS models, for the most part, already would comply with the new FMVSS No. 213b test requirements. NHTSA also does not believe that making labeling changes and testing requirements effective on two different dates would be confusing to the consumer. The labeling changes and testing are transparent to the consumer; they usually do not know how CRSs are tested and the labeling changes with different weight and height recommendations will simply guide whether to buy and/or how to use a CRS.

If early compliance is chosen by a manufacturer for a CRS model, the CRS model must meet all applicable requirements in FMVSS No. 213, including the amendments to FMVSS No. 213 made by this final rule, or all applicable requirements in FMVSS No. 213b. Manufacturers will not be allowed to pick and choose among the requirements within a standard or comply early with some in a standard and not in others. In part, this provision is to support the efficiency of NHTSA's compliance program.²¹⁸ If manufacturers were permitted to pick and choose which

²¹⁸ This provision is regularly used by NHTSA when the agency permits optional early compliance with a standard. The agency restricts manufacturers from selectively meeting some but not all of the amended requirements.

requirements they would like to meet early, NHTSA would have to keep track of the standard's individual requirement according to manufacturer's input on hundreds of CRS models. NHTSA seeks to limit such burdens on the compliance program. In addition, the requirement reduces potential consumer confusion about which standards a purchased CRS meets. If manufacturers were permitted to meet some requirements early but not others, consumers may believe they purchased a CRS meeting, for example, the upgraded standard FMVSS No. 213b when the CRS did not meet all the requirements in FMVSS No. 213b. NHTSA would like to avoid this possible source of consumer misunderstanding. This would also allow for a more equitable enforcement across manufacturers with the two distinct updates to the standard.

Under § 30111(d) of the Safety Act, a standard may not become effective before the 180th day after the standard is prescribed or later than one year after it is prescribed, unless NHTSA finds, for good cause shown, that a different effective date is in the public interest and publishes the reasons for the finding. A 3-year compliance period is in the public interest because CRS manufacturers need to gain familiarity with the updated standard seat assembly and new test protocols and will need time to assess their products' conformance to the new FMVSS No. 213b requirements. They will need time to implement appropriate design and production changes. A 3-year lead time is also appropriate because it aligns with the typical design cycle of child restraints. Aligning with design cycles can help reduce the cost of compliance and possible price increases on consumers.

The 3-year compliance date for the final rule, with the early compliance option, provides the same 3-year lead time as the final rule establishing FMVSS No. 213a, "Child restraint systems – Side impact protection" (87 FR 39234, June 30, 2022). The compliance date for FMVSS No. 213a is June 30, 2025, with optional early compliance permitted. NHTSA does not see a reason to delay the compliance date of the side impact rule another year, or to shorten the lead time for this final rule a year. Making the compliance dates of the two rules coincide has some merit but the consequences of aligning them with regard to this final rule and the side

impact protection standard (FMVSS No. 213b) outweigh such merit. With the option for early compliance, manufacturers have sufficient flexibility in deciding how they will meet these final rules.

XV. Regulatory Notices and Analyses

Executive Order (E.O.) 12866, E.O. 13563, E.O. 14094 and DOT Rulemaking Procedures

The agency has considered the impact of this rulemaking action under E.O. 12866, E.O. 13563, E.O. 14094, and the Department of Transportation's regulatory procedures. This final rule is nonsignificant under E.O. 12866 and E.O. 14094 and was not reviewed by the Office of Management and Budget. It is also not considered “of special note to the Department” under DOT Order 2100.6A, *Rulemaking and Guidance Procedures*.

Estimated Benefits and Costs

This final rule amends FMVSS No. 213 by (a) updating the standard seat assembly to better represent the rear seating environment in the current vehicle fleet, (b) amending several labeling and owner information requirements to improve communication with today’s CRS caregivers and to align with current best practices for child passenger safety, and (c) amending how NHTSA uses dummies to make the agency’s compliance tests more evaluative of CRS performance. The rule will provide some safety benefits with, at most, minimal incremental costs.

Updated Standard Seat Assembly

The updates to the standard seat assembly in this final rule will better align the performance of CRSs in compliance tests to that in real world crashes.

Based on NHTSA’s tests of CRS models representing the market of infant carrier, convertible, all-in-one, and booster type CRSs on the updated standard seat assembly, the agency believes that only a few CRSs may need to be redesigned to meet the requirements of the

standard on the updated standard seat assembly, and that those redesigns will be minor.²¹⁹

NHTSA is providing a lead time of three years for the redesign. The agency has not estimated a cost of this redesign, as we assume the redesign could be incorporated into a typical business model involving manufacturers refining child restraint designs to freshen their product lines. The refinements result in new product offerings that appeal to consumers and help manufacturers remain competitive.

There will be costs involved in changing to the updated standard seat assembly used by NHTSA to assess CRS compliance. However, manufacturers are not required to use the updated standard seat assembly. As a practical matter they usually choose to do so to test their CRSs as similarly to the way NHTSA will test them, but it is not a requirement to so test. The one-time cost of the updated standard seat assembly sled buck is about \$9,300. If a manufacturer chooses to build the assembly itself or uses one at an independent test facility, either way there would be minimal cost impacts when the cost of the assembly and testing CRSs is distributed among the hundreds of thousands of CRSs that would be sold by the manufacturers.

We are retaining the Type 1 seat belt assembly test for an additional 3 years (2029) so there will be temporary additional annual test costs of \$5,198,000²²⁰ for testing with the Type 1 seat belt assembly up to the year 2029.

Labeling and Owner Registration

²¹⁹ Preliminary tests with the updated standard seat assembly using an average 23.3 g peak acceleration pulse and an average 47.5 km/h (29.5 mph) velocity within the FMVSS No. 213 acceleration corridor showed dummy HIC and chest accelerations in some booster seats, tested with the HIII-6YO and HIII-10YO dummies, near or exceeding allowable threshold levels. While NHTSA expects that some booster seats may need to be redesigned to meet the performance measures when tested with a higher acceleration pulse, these redesigns could be accomplished without additional material cost. For example, different foams could be used in the CRS seating cushions that work better with the proposed stiffer standard seat cushion foam to lower the HIC and chest g values.

²²⁰ There are currently 70 infant carrier models, 48 convertible CRS models, 60 all-in-one CRS models and 21 combination CRS models. Each infant carrier would be tested in 2 configurations with Type 1 seat belt including with and without base. Each convertible and all-in-one CRS would be tested using Type 1 seat belt installation in rear facing, forward facing and forward facing with tether. Each combination CRS would be tested using Type 1 seat belt installation in forward facing and forward facing with tether. Each CRS would be subject to tests on average between 1 to 3 dummies. The cost of a sled test is estimated at \$4,600. Therefore, the temporary additional test cost is estimated to be \$5,198,000.

The agency believes that the updates to the labeling requirements will benefit safety by reducing the premature transition of children from CRSs used rear-facing to forward-facing CRSs, and from forward-facing CRSs to booster seats. The agency estimates 1.9 to 6.3 lives will be saved and 2.6 to 8.7 moderate-to-critical severity injuries will be prevented annually by aligning FMVSS No. 213's CRS user instructions with current best practices on transporting children.²²¹

The changes to the labeling requirements will have minimal or no cost impacts, as mostly they are voluntary. This final rule provides manufacturers the flexibility to provide required information in statements or a combination of statements and pictograms at locations that they deem most effective. Manufacturers may provide child weight and height ranges for the use of CRSs in a specific installation mode on existing labels by simply changing the minimum child weight limit values. Since no additional information is required on the labels by this final rule, the size of the label does not need to be increased. Thus, there will be minimal or no additional cost for the labels. There will also be no decrease in sales of forward-facing child restraint systems or of booster seats as a result of the final rule's provisions to raise the minimum child weight limit values for forward-facing CRSs and booster seats. Most forward-facing CRSs cover a wide child weight range, so the labeling changes will only affect how caregivers use the products and not the quantity sold. For example, caregivers will still purchase forward-facing CRSs but will use them when the child is at least 1. They will still purchase convertible CRSs but will not turn them forward-facing until the child is at least 1. They will still purchase booster seats but will only move the child into them when the child reaches 18.2 kg (40 lb).

The changes to the registration program generally lessen restrictions and are optional for manufacturers to implement. These changes to the registration card provide flexibility to manufacturers in how they communicate with consumers and will likely help improve registration rates and recall completion rates. NHTSA cannot quantify the benefits at this time.

²²¹ Details of the benefits analysis are provided in the Appendix to the November 2, 2020 NPRM. 85 FR at 69455.

NHTSA estimates there are no costs associated with the changes. While the changes could affect the collection of information pursuant to the Paperwork Reduction Act (which is discussed later in this section), there are no additional material costs associated with the changes to the registration card or to the CRS label or printed instructions pertaining to registration.

Manufacturers could use the same card and labels and just change the wording on them.

Dummies

The updates to how dummies are used in the test for assessing CRS performance better accord with current CRS designs and best practices for transporting child passengers compared to the current specifications in FMVSS No. 213. NHTSA cannot quantify the possible safety benefits at this time.

Some of the changes lessen testing burdens by reducing the extent of testing with dummies. For example, the final rule specifies that CRSs for children weighing 10 kg to 13.6 kg (22 to 30 lb) will no longer be subject to certification with the HIII-3YO dummy. NHTSA estimates a reduction in testing cost of \$717,600 for the current number of infant carrier models in the market.²²² Also, CRSs for children weighing 13.6 to 18.2 kg (30 to 40 lb) will no longer be certified with the CRABI-12MO. However, the agency does not expect any reduction in testing costs from this latter modification since all CRSs with internal harnesses are sold for children weighing less than 13.6 kg (30 lb), and so are still subject to testing with the CRABI-12MO in that regard. The final rule also provides that the CRABI-12MO dummy will no longer be used in forward-facing tests. NHTSA estimates a reduction in testing cost of \$2,373,600²²³ for the

²²² There are currently 52 infant carrier models with recommended upper weight limit exceeding 10 kg (22 lb). Each CRS designed for rear-facing use is tested in three different configurations on the updated standard seat assembly with each dummy used for testing the CRS: (1) CRS installed using seat belts, (2) CRS installed using the lower anchors and no tether, and (3) CRS installed without the base using the lower anchors and no tether. The cost of a sled test is estimated at \$4,600. Therefore, the cost savings by not testing the 52 infant carrier models using the HIII-3YO dummy is estimated to be \$717,600 ($= \$4,600 \times 3 \times 52$). Since manufacturers typically conduct more than one test in each of the CRS installation configurations, NHTSA expects the actual cost savings to be greater than the estimated \$717,600.

²²³ There are currently 129 forward facing CRSs (including convertibles, all-in-one and combination) that would no longer be tested with the CRABI-12MO. Each forward-facing CRS is tested in the following different configurations: (1) CRS installed using Type 2 seat belts, (2) CRS installed using Type 2 seat belts and tether, (3) CRS installed using the lower anchors and no tether, and (4) CRS installed using the lower anchors and tether. The

forward-facing CRSs that will no longer be certified with the CRABI-12MO. The positioning procedure for the legs of the HIII-3YO dummy in CRSs used rear-facing is unlikely to have cost implications because the procedure is the same as that currently used by manufacturers.

Similarly, NHTSA believes that testing CRSs solely with the HIII-6YO rather than the H2-6YO dummy will not have significant cost implications. This is because there would be little or no design changes needed for the CRSs since nearly all the CRSs tested with the HIII-6YO on the standard seat assembly complied with all the FMVSS No. 213 requirements.²²⁴ While some commenters (Graco, JPMA, Dorel and Evenflo) opposed the proposal as they believe chin-to-chest contacts have not been resolved, the data presented showed that the CRSs are still capable of meeting the updated standard with the HIII-6YO. NHTSA's testing also showed that CRSs that currently comply with FMVSS No. 213 using the H2-6YO dummy also met all the performance requirements in the standard when tested using the HIII-6YO dummy on the new standard seat assembly. Manufacturers are increasingly certifying at least some of their CRS models for older children using the HIII-6YO dummy rather than the H2-6YO. This shows that most manufacturers already have access to the HIII-6YO dummy and use it. Most CRS manufacturers hire commercial test labs to test their CRSs for conformance with FMVSS No. 213 requirements. These labs already have the HIII-6YO dummy since some of their CRS manufacturer clients currently want to certify their CRSs based on tests with the HIII-6YO dummy. Thus, NHTSA believes there will not be an additional cost associated with purchasing and testing with the HIII-6YO dummy.

NHTSA believes that a lead time of three years is sufficient for redesigning CRSs that may need modifications to comply with the amendment. Most CRSs will need minor or no modifications as a result of the final rule. Further, a 3-year time frame aligns with the typical design cycle for CRSs. The agency notes also that the rule is designed so that manufacturers can

cost of a sled test is estimated at \$4,600. Therefore, the cost savings by not testing the 129 forward facing models using the CRABI-12MO dummy is estimated to be \$2,373,600 (= \$4,600 × 4 × 129).

²²⁴ Of 21 tests with the HIII-6YO on the updated standard seat assembly, all passed the performance metrics, except for one that failed head excursion limits.

simply change the weight of the children for whom the CRS is recommended to meet some of the requirements. Narrowing the population of children for whom the CRS is recommended reduces the certification burden on manufacturers as well as the number of tests NHTSA may run to assess compliance.

School Bus Child Restraint Systems

The changes to include in FMVSS No. 213 a new type of add-on CRS manufactured for exclusive use on school bus seats allow the sale of these products. The agency estimates there are no cost impacts associated with the changes because the amendment is permissive in nature. The changes will benefit school bus transportation by permitting more devices to be developed and used to transport preschool children and children with special needs. However, NHTSA cannot quantify these benefits at this time.

Regulatory Flexibility Act

Pursuant to the Regulatory Flexibility Act (5 U.S.C. 601 et seq., as amended by the Small Business Regulatory Enforcement Fairness Act (SBREFA) of 1996), whenever an agency is required to publish a notice of proposed rulemaking or final rule, it must prepare and make available for public comment a regulatory flexibility analysis that describes the effect of the rule on small entities (i.e., small businesses, small organizations, and small governmental jurisdictions), unless the head of an agency certifies the rule will not have a significant economic impact on a substantial number of small entities. Agencies must also provide a statement of the factual basis for this certification.

I certify that this rule will not have a significant economic impact on a substantial number of small entities. NHTSA estimates there to be 38 manufacturers of child restraints, none of which are small businesses. Even if there were a small CRS manufacturer, the impacts of this rule will not be significant. NHTSA believes that virtually all CRSs would meet FMVSS No. 213's requirements on the new seat assembly without modification. Manufacturers may need to change

the labels on their child restraints pursuant to the requirements, but the changes are minor and can be met by simply switching out values on current labels.

National Environmental Policy Act

NHTSA has analyzed this rule for the purposes of the National Environmental Policy Act and determined that it would not have any significant impact on the quality of the human environment.

Executive Order 13132 (Federalism)

NHTSA has examined today's rule pursuant to Executive Order 13132 (64 FR 43255, August 10, 1999) and concluded that no additional consultation with States, local governments or their representatives is mandated beyond the rulemaking process. The agency has concluded that the rulemaking would not have sufficient federalism implications to warrant consultation with State and local officials or the preparation of a federalism summary impact statement. The rule will not have "substantial direct effects on the States, on the relationship between the national government and the States, or on the distribution of power and responsibilities among the various levels of government."

NHTSA rules can preempt in two ways. First, the National Traffic and Motor Vehicle Safety Act contains an express preemption provision: When a motor vehicle safety standard is in effect under this chapter, a State or a political subdivision of a State may prescribe or continue in effect a standard applicable to the same aspect of performance of a motor vehicle or motor vehicle equipment only if the standard is identical to the standard prescribed under this chapter. 49 U.S.C. § 30103(b)(1). It is this statutory command by Congress that preempts any non-identical State legislative and administrative law addressing the same aspect of performance.

The express preemption provision described above is subject to a savings clause under which "[c]ompliance with a motor vehicle safety standard prescribed under this chapter does not exempt a person from liability at common law." 49 U.S.C. § 30103(e). Pursuant to this provision, State common law tort causes of action against motor vehicle manufacturers that

might otherwise be preempted by the express preemption provision are generally preserved. However, the Supreme Court has recognized the possibility, in some instances, of implied preemption of such State common law tort causes of action by virtue of NHTSA's rules, even if not expressly preempted. This second way that NHTSA rules can preempt is dependent upon there being an actual conflict between an FMVSS and the higher standard that would effectively be imposed on motor vehicle manufacturers if someone obtained a State common law tort judgment against the manufacturer, notwithstanding the manufacturer's compliance with the NHTSA standard. Because most NHTSA standards established by an FMVSS are minimum standards, a State common law tort cause of action that seeks to impose a higher standard on motor vehicle manufacturers will generally not be preempted. However, if and when such a conflict does exist - for example, when the standard at issue is both a minimum and a maximum standard - the State common law tort cause of action is impliedly preempted. See Geier v. American Honda Motor Co., 529 U.S. 861 (2000).

Pursuant to Executive Order 13132 and 12988, NHTSA has considered whether this final rule could or should preempt State common law causes of action. The agency's ability to announce its conclusion regarding the preemptive effect of one of its rules reduces the likelihood that preemption will be an issue in any subsequent tort litigation. To this end, the agency has examined the nature (e.g., the language and structure of the regulatory text) and objectives of today's rule and finds that this rule, like many NHTSA rules, would prescribe only a minimum safety standard. As such, NHTSA does not intend that this rule would preempt state tort law that would effectively impose a higher standard on motor vehicle manufacturers than that established by today's rule. Establishment of a higher standard by means of State tort law would not conflict with the minimum standard adopted here. Without any conflict, there could not be any implied preemption of a State common law tort cause of action.

Civil Justice Reform

With respect to the review of the promulgation of a new regulation, section 3(b) of Executive Order 12988, “Civil Justice Reform” (61 FR 4729, February 7, 1996) requires that Executive agencies make every reasonable effort to ensure that the regulation: (1) Clearly specifies the preemptive effect; (2) clearly specifies the effect on existing Federal law or regulation; (3) provides a clear legal standard for affected conduct, while promoting simplification and burden reduction; (4) clearly specifies the retroactive effect, if any; (5) adequately defines key terms; and (6) addresses other important issues affecting clarity and general draftsmanship under any guidelines issued by the Attorney General. This document is consistent with that requirement.

Pursuant to this Order, NHTSA notes as follows. The preemptive effect of this rule is discussed above. NHTSA notes further that there is no requirement that individuals submit a petition for reconsideration or pursue other administrative proceeding before they may file suit in court.

National Technology Transfer and Advancement Act

Under the National Technology Transfer and Advancement Act of 1995 (NTTAA) (Public Law 104-113), all Federal agencies and departments shall use technical standards that are developed or adopted by voluntary consensus standards bodies, using such technical standards as a means to carry out policy objectives or activities determined by the agencies and departments. Voluntary consensus standards are technical standards (e.g., material specifications, test methods, sampling procedures, and business practices) that are developed or adopted by voluntary consensus standards bodies, such as the International Organization for Standardization (ISO) and the SAE International (SAE). The NTTAA directs the agency to provide Congress, through OMB, explanations when the agency decides not to use available and applicable voluntary consensus standards. NHTSA searched for but did not find voluntary consensus standards directly applicable to the amendments in this final rule, other than ASTM D3574-11 “Standard Test Methods for Flexible Cellular Materials—Slab, Bonded, and Molded Urethane

Foams,” and the minor amendment to update the reference to SAE Recommended Practice J211/1 to the March 1995 version.

However, consistent with the NTTAA, NHTSA reviewed the procedures and regulations developed globally to dynamically test child restraints and found areas of common ground.²²⁵ While there is no single procedure or regulation of another country that sufficiently replicates frontal crashes occurring in the U.S., the agency considered various aspects of international regulations pertaining to the testing of child restraint systems. NHTSA analyzed aspects of the seating assemblies used by NPACS, ECE R.44 and Transport Canada’s CMVSS No. 213 and the frontal test speeds used worldwide in sled tests. NHTSA adopts a requirement to test CRSs with Type 2 (3-point) seat belts, which is consistent with CMVSS No. 213. NHTSA concludes that the provisions increase CRS safety and promote harmonization of our countries’ regulatory approaches in testing CRSs.

Unfunded Mandates Reform Act

Section 202 of the Unfunded Mandates Reform Act of 1995 (UMRA), Pub. L. 104-4, requires Federal agencies to prepare a written assessment of the costs, benefits, and other effects of proposed or final rules that include a Federal mandate likely to result in the expenditure by State, local, or Tribal governments, in the aggregate, or by the private sector, of more than \$100 million annually (adjusted for inflation with base year of 1995). Adjusting this amount by the implicit gross domestic product price deflator for the year 2010 results in \$136 million ($110.993/81.606 = 1.36$). This rule will not result in a cost of \$136 million or more to either State, local, or Tribal governments, in the aggregate, or the private sector. Thus, this rule is not subject to the requirements of sections 202 of the UMRA.

Executive Order 13609 (Promoting International Regulatory Cooperation)

²²⁵ The NTTAA seeks to support efforts by the Federal government to ensure that agencies work with their regulatory counterparts in other countries to address common safety issues. Circular No. A-119, “Federal Participation in the Development and Use of Voluntary Consensus Standards and in Conformity Assessment Activities,” January 27, 2016, p. 15.

The policy statement in section 1 of E.O. 13609 provides, in part:

The regulatory approaches taken by foreign governments may differ from those taken by U.S. regulatory agencies to address similar issues. In some cases, the differences between the regulatory approaches of U.S. agencies and those of their foreign counterparts might not be necessary and might impair the ability of American businesses to export and compete internationally. In meeting shared challenges involving health, safety, labor, security, environmental, and other issues, international regulatory cooperation can identify approaches that are at least as protective as those that are or would be adopted in the absence of such cooperation. International regulatory cooperation can also reduce, eliminate, or prevent unnecessary differences in regulatory requirements.

NHTSA received a comment from the People's Republic of China making suggestions about flammability and side impact requirements for child restraints. The comment was out of the scope of this rulemaking.

In the discussion above on the NTTAA, NHTSA has noted that it has reviewed the procedures and regulations developed by Transport Canada regarding testing CRSs with Type 2 (3-point) seat belts and agrees with the merits of the CMVSS No. 213 provision.

Paperwork Reduction Act

Under the Paperwork Reduction Act of 1995, a person is not required to respond to a collection of information by a Federal agency unless the collection displays a valid OMB control number. Before seeking OMB approval, Federal agencies must provide a 60-day public comment period and otherwise consult with members of the public and affected agencies concerning each collection of information requirement. NHTSA believes the changes to the owner registration program (571.213, S5.8) constitute changes to a "collection of information" requirement for child restraint system manufacturers. NHTSA is providing a 60-day comment period on reporting burdens and other matters associated with the owner registration program new requirements.

OMB has promulgated regulations describing what must be included in the request for comment document. Under OMB's regulation (at 5 CFR 1320.8(d)), an agency must ask for public comment on the following:

Whether the proposed collection of information is necessary for the proper performance of the functions of the agency, including whether the information will have practical utility;

The accuracy of the agency's estimate of the burden of the proposed collection of information, including the validity of the methodology and assumptions used;

How to enhance the quality, utility, and clarity of the information to be collected;

How to minimize the burden of the collection of information on those who are to respond, including the use of appropriate automated, electronic, mechanical, or other technological collection techniques or other forms of information technology, e.g., permitting electronic submission of responses.

In compliance with these requirements, NHTSA asks for public comments on the following proposed collection of information:

Title: "Consolidated Child Restraint System Registration, Labeling and Defect Notifications."

OMB Control Number: 2127-0576.

Requested Expiration Date of Approval: Three years from the approval date.

Type of Request: Revision of a currently approved collection.

Affected Public: Businesses, Individuals and Households.

Summary of the Collection of Information:

Child restraint manufacturers are required to provide an owner registration card for purchasers of child restraint systems in accordance with title 49 of the Code of Federal Regulations (CFR), part 571, section 213, "Child restraint systems." The registration card is required to be perforated into two parts. The top part (information part) contains a message and suitable instructions to be retained by the purchaser. The size, font, color, and layout of the top part are currently prescribed

in Figures 9a and 9b,²²⁶ as is the attachment method (fold/perforation) of the information card to the lower part of the form (the mail-in card). The top part of the registration card sets forth: (a) prescribed wording advising the consumer of the importance of registering; (b) prescribed instructions on how to register; and (c) prescribed statements that the mail-in card is pre-addressed and that postage is already paid.

The bottom part (the mail-in card) is to be returned to the manufacturer by the purchaser. The bottom part includes prepaid return postage, the pre-printed name/address of the manufacturer, the pre-printed model and date of manufacture, and spaces for the purchaser to fill in his/her name and address. Optionally, child restraint manufacturers are permitted to add to the registration form: (a) Specified statements informing CRS owners that they may register online; (b) the Internet address for registering with the company; (c) revisions to statements reflecting use of the Internet to register; and (d) a space for the consumer's email address.

Child restraint manufacturers are also required to provide printed instructions with new CRSs, with step-by-step information on how the restraint is to be used, and a permanently attached label that gives "quick look" information on matters such as use instructions and information on registering the CRS.

Under this final rule, the agency is amending the requirements that prescribe wording advising the consumer of the importance of registering their CRS and instructing how to register. NHTSA is adopting changes to stop prescribing the wording. Instead, CRS manufacturers are given leeway to use their own words to convey the importance of registering the CRS and to instruct how registration is achieved. NHTSA will allow statements instructing consumers to use electronic (or any other means) of registering, as long as instructions are provided on using the paper card for registering (including that the mail-in card is pre-addressed and that the postage is

²²⁶ Prescribed in FMVSS No. 213, "Child restraint systems." As discussed in this preamble, this NPRM proposes to relieve some of those restrictions.

pre-paid). NHTSA will allow other means of electronic registration other than a web address, such as a QR code, tme URL, or similar.

In this final rule, the agency is also removing restrictions on manufacturers on their use of size, font, color, layout, and attachment method of the information card portion. NHTSA is continuing a current provision that prohibits any other information unrelated to the registration of the CRS, such as advertising or warranty information.

With the changes to the information card adopted in this final rule, NHTSA anticipates a change to the hour burden or costs associated with the revised information card, labels and printed instructions. Child restraint systems manufacturers produce, on average, a total of approximately 16,000,000 child restraint systems per year. NHTSA estimates there are 38 CRS manufacturers with 159 distinct CRS models.

The hour burden associated with the revised label consists of the child restraint manufacturer: (a) designing the information card with statements to instruct how to register, encourage registration and optionally, how to register electronically and how the submitted information will be used; and (b) updating this information on the existing information card, label and printed instructions. NHTSA assumes for purposes of this analysis that each manufacturer would design the registration information on the information card, label and printed instructions 5 times per year, whether it is to use different registration card designs in different CRS models or to adapt the design to improve registrations. The agency estimates 50 hours of additional burden per child restraint manufacturer for the designing of the registration card (information card portion), labels and printed instructions that no longer have prescribed text (50 hours X 5 designs/year X 38 CRS manufacturers = 9,599 hours annually).

Estimated Additional Annual Burden: 9,500 hours

The burden of designing labels and printed instruction is minimal. CRS manufacturers use templates to include in their CRSs. The design of the basic label design is adjusted with necessary changes based on the different models. Specific CRS labels can readily be created

through editing of text and insertion of updated diagrams. Therefore, there is no new annualized burden associated with label and instruction development.

Comments are invited on: Whether the described collection of information is necessary for the proper performance of the functions of the Department, including whether the information will have practical utility; the accuracy of the Department's estimate of the burden of the proposed information collection; ways to enhance the quality, utility and clarity of the information to be collected; and ways to minimize the burden of the collection of information on respondents, including the use of automated collection techniques or other forms of information technology.

You may submit comments (identified by the DOT Docket ID Number above) by any of the following methods:

- Federal eRulemaking Portal: Go to <http://www.regulations.gov>. Follow the online instructions for submitting comments.
- Mail: Docket Management Facility: U.S. Department of Transportation, 1200 New Jersey Avenue S.E., West Building Ground Floor, Room W12-140, Washington, D.C. 20590-0001.
- Hand Delivery or Courier: West Building Ground Floor, Room W12-140, 1200 New Jersey Avenue S.E., Washington, D.C., 20590-0001 between 9 a.m. and 5 p.m. ET, Monday through Friday, except Federal holidays.
- Fax: 202-493-2251.

Regardless of how you submit your comments, you should mention the docket number of this document. You may call the Docket at (202) 366-9826. Please identify the proposed collection of information for which a comment is provided, by referencing its OMB clearance number. It is requested, but not required, that two copies of the comment be provided.

Note that all comments received will be posted without change to <http://www.regulations.gov>, including any personal information provided. Anyone is able to search the electronic form of all

comments received into any of our dockets by the name of the individual submitting the comment (or signing the comment, if submitted on behalf of an association, business, labor union, etc.). You may review DOT's complete Privacy Act Statement in the **Federal Register** published on April 11, 2000 (65 FR 19477-78).

Incorporation by Reference

In updating the standard seat assembly used in the FMVSS No. 213 frontal test, NHTSA incorporates by reference a drawing package titled, "Parts List and Drawings, NHTSA Standard Seat Assembly; FMVSS No. 213, No. NHTSA-213-2021, Child Frontal Impact Sled" dated March 2023, into FMVSS No. 213 (49 CFR 571.213). The drawing package consists of detailed drawings and other materials related to the standard seat assembly referenced in this final rule. Interested persons could use the drawing package to manufacture the standard seat assembly for their own use if they wished to do so.

NHTSA has placed a copy of the drawing package in the docket for this final rule. Interested parties can download a copy of the drawing package or view the materials on-line by accessing www.Regulations.gov.

This final rule also removes an incorporation by reference of SAE Recommended Practice J211, "Instrumentation for Impact Tests," revised 1980, and replaces it with the 1995 version of J211 (J211/1) in FMVSS No. 213 and FMVSS No. 213b (49 CFR 571.213b). The SAE J211/1 standard provides guidelines and recommendations for techniques of measurements used in impact tests to achieve uniformity in instrumentation practice and in reporting results. Signals from impact tests have to be filtered following the standard's guidelines to eliminate noise from sensor signals. Following J211/1 guidelines provides a basis for meaningful comparisons of test results from different sources. This final rule amends 49 CFR 571.5 to remove the reference to § 571.213 from the SAE recommended practice J211, "Instrumentation for Impact Tests," revised 1980. . Interested parties can obtain a copy of the SAE Recommended Practice J211/1 "Instrumentation for Impact Test—Part 1—Electronic Instrumentation," from

SAE International, 400 Commonwealth Drive, Warrendale, PA 15096. Telephone: (724) 776-4841, Website: www.sae.org.

This final rule also incorporates by reference the standard ASTM D3574-11 “Standard Test Methods for Flexible Cellular Materials—Slab, Bonded, and Molded Urethane Foams” in FMVSS No. 213b. ASTM D3574 is a standard method for testing flexible cellular urethane and polyurethane foams. ASTM D3574 is used to measure and evaluate flexible foam properties, including: density and indentation force deflection (IFD).

This final rule incorporates by reference ASTM D1056-07, Standard Specification for Flexible Cellular Materials-Sponge or Expanded Rubber, into FMVSS No. 213b. ASTM D1056-07 is a standard for cellular materials, both Sponge (Open Cell) and Expanded (Closed Cell). ASTM D1056 specifies several different procedures for testing flexible cellular materials. The tests include a compression deflection test, accelerated aging tests, compression-deflection tests, an oil-immersion test (open-cell sponge); fluid immersion tests (closed cell); a water absorption test; density tests; and a low-temperature flex test.

Interested parties can obtain a copy of the ASTM standards from ASTM International at 100 Barr Harbor Drive, P.O. Box C700, West Conshohocken, PA. Telephone: (877) 909-2786, Website: www.astm.org/.

This final rule incorporates by reference the American Association of Textile Chemists and Colorists (AATCC) Gray Scale for Color Change. AATCC Gray Scale for Color Change is used for assessing color change during color fastness testing. The scale is used for visual assessment to enable users to specify a rating from 1 to 5. Interested parties can obtain the AATCC Gray Scale for Color Change at PO Box 12215 Research Triangle Park, NC, USA. Telephone: (919) 549-8141, Website: www.aatcc.org/.

This final rule incorporates by reference Drawing No. 210–5000–1(L), –2(R), Leg Assembly. The drawing shows the assembly and parts of the 3-year-old dummy (49 CFR part 572, subpart P) dummy’s legs. The drawing can be found in Docket No. NHTSA-2001-11171-

0004 in www.regulations.gov (<https://www.regulations.gov/document/NHTSA-2001-11171-0004>).

The following standards appear in the amendatory text of this document and were previously approved for the locations in which they appear: Drawing Package, SAS-100-1000, Standard Seat Belt Assembly with Addendum A, Seat Base Weldment (consisting of drawings and a bill of materials), October 23, 1998; and Drawing Package, “NHTSA Standard Seat Assembly; FMVSS No. 213, No. NHTSA-213-2003,” (consisting of drawings and a bill of materials), June 3, 2003.

Severability

The issue of severability of FMVSSs is addressed in 49 CFR 571.9. It provides that if any FMVSS or its application to any person or circumstance is held invalid, the remainder of the part and the application of that standard to other persons or circumstances is unaffected.

Regulation Identifier Number

The Department of Transportation assigns a regulation identifier number (RIN) to each regulatory action listed in the Unified Agenda of Federal Regulatory and Deregulatory Actions. The Regulatory Information Service Center publishes the Unified Agenda in April and October of each year. You may use the RIN contained in the heading at the beginning of this document to find this action in the Unified Agenda.

Plain Language

Executive Order 12866 requires each agency to write all rules in plain language. Application of the principles of plain language includes consideration of the following questions:

- Have we organized the material to suit the public's needs?
- Are the requirements in the rule clearly stated?
- Does the rule contain technical language or jargon that isn't clear?
- Would a different format (grouping and order of sections, use of headings, paragraphing) make the rule easier to understand?

- Would more (but shorter) sections be better?
- Could we improve clarity by adding tables, lists, or diagrams?
- What else could we do to make the rule easier to understand?

NHTSA has considered these questions and attempted to use plain language in writing this rule. Please inform the agency if you can suggest how NHTSA can improve its use of plain language.

How Do I Submit Confidential Business Information?

NHTSA is currently treating electronic submission as an acceptable method for submitting confidential business information to the agency under Part 512. If you claim that any of the information or documents provided in your submission constitutes confidential business information within the meaning of 5 U.S.C. § 552(b)(4) or are protected from disclosure pursuant to 18 U.S.C. § 1905, you may either submit your request via email or request a secure file transfer link from the Office of the Chief Counsel contact listed below. You must submit supporting information together with the materials that are the subject of the confidentiality request, in accordance with Part 512, to the Office of the Chief Counsel. Do not send a hardcopy of a request for confidential treatment to NHTSA's headquarters.

Your request must include a request letter that contains supporting information, pursuant to Part 512.8. Your request must also include a certificate, pursuant to Part 512.4(b) and Part 512, Appendix A.

You are required to submit one unredacted "confidential version" of the information for which you are seeking confidential treatment. Pursuant to Part 512.6, the words "ENTIRE PAGE CONFIDENTIAL BUSINESS INFORMATION" or "CONFIDENTIAL BUSINESS INFORMATION CONTAINED WITHIN BRACKETS" (as applicable) must appear at the top of each page containing information claimed to be confidential. In the latter situation, where not all information on the page is claimed to be confidential, identify each item of information for which confidentiality is requested within brackets: "[]."

You are also required to submit one redacted “public version” of the information for which you are seeking confidential treatment. Pursuant to Part 512.5(a)(2), the redacted “public version” should include redactions of any information for which you are seeking confidential treatment (i.e., the only information that should be unredacted is information for which you are not seeking confidential treatment). For questions about a request for confidential treatment, please contact Dan Rabinovitz in the Office of the Chief Counsel at Daniel.Rabinovitz@dot.gov.

XVI. Appendices to the Preamble

Appendix A to the Preamble: Reproducibility Test Results

| Evenflo Embrace 35 - CRABI - Infant - LA Only | | | | | |
|--|----------------------------|------------------------------|--------------|---------------------------|-----------------|
| Test Number | Sled Velocity (mph) | Test Acceleration (g) | HIC36 | Chest Clip 3ms (g) | RF Angle |
| RR06-19-28 | 30.1 | 23.6 | 660 | 54.8 | 51 |
| RR06-19-29 | 30.0 | 23.5 | 632 | 54.6 | 51 |
| RR06-19-30 | 30.0 | 23.5 | 637 | 55.9 | 52 |
| Calspan | | St. Dev. | 14.9 | 0.7 | 0.5 |
| | | Average | 642.8 | 55.1 | 51.4 |
| | | %CV | 2.3 | 1.3 | 0.9 |
| UFSSA117 | 29.8 | 21.2 | 609 | 51.2 | 55 |
| UFSSA118 | 29.7 | 21.1 | 640 | 55.0 | 53 |
| UFSSA119 | 29.8 | 21.2 | 602 | 50.9 | 57 |
| MCW | | St. Dev. | 20.2 | 2.3 | 2.1 |
| | | Average | 617.1 | 52.4 | 55.0 |
| | | %CV | 3.3 | 4.4 | 3.8 |
| FR_RR1_24 | 29.4 | 20.9 | 566 | 53.7 | 47 |
| FR_RR1_26 | 29.4 | 21.1 | 617 | 58.7 | 44 |
| FR_RR1_28 | 29.4 | 21.0 | 556 | 48.6 | 45 |
| TRC | | St. Dev. | 32.5 | 5.0 | 1.6 |
| | | Average | 579.7 | 53.7 | 45.4 |
| | | %CV | 5.6 | 9.4 | 3.4 |
| All Tests | | St. Dev. | 34.3 | 3.0 | 4.4 |
| | | Average | 613.2 | 53.7 | 50.6 |
| | | %CV | 5.6 | 5.7 | 8.7 |

| |
|--|
| Evenflo Embrace 35 - CRABI - Infant - SB3PT |
|--|

| Test Number | Sled Velocity (mph) | Test Acceleration (g) | HIC36 | Chest Clip 3ms (g) | RF Angle |
|-------------|---------------------|-----------------------|-------|--------------------|----------|
| RR02-20-12 | 30.0 | 23.2 | 560 | 47.2 | 50 |
| RR02-20-13 | 29.7 | 22.9 | 567 | 46.9 | 52 |
| RR02-20-14 | 29.7 | 23.0 | 557 | 46.0 | 51 |
| Calspan | | St. Dev. | 5.2 | 0.6 | 0.9 |
| | | Average | 561.2 | 46.7 | 51.2 |
| | | %CV | 0.9 | 1.3 | 1.7 |
| UFSSA210 | 29.3 | 21.7 | 667 | 52.0 | 54 |
| UFSSA211 | 29.6 | 21.8 | 627 | 49.7 | 54 |
| UFSSA212 | 29.3 | 21.6 | 623 | 52.3 | 52 |
| MCW | | St. Dev. | 24.4 | 1.4 | 1.1 |
| | | Average | 639.0 | 51.3 | 53.6 |
| | | %CV | 3.8 | 2.7 | 2.0 |
| All Tests | | St. Dev. | 45.4 | 2.7 | 1.6 |
| | | Average | 600.1 | 49.0 | 52.4 |
| | | %CV | 7.6 | 5.6 | 3.0 |

Chicco Key Fit - CRABI - Infant - LA Only

| Test Number | Sled Velocity (mph) | Test Acceleration (g) | HIC36 | Chest Clip 3ms (g) | RF Angle |
|-------------|---------------------|-----------------------|-------------|--------------------|----------|
| RR06-19-34 | 29.7 | 23.1 | 380 | 43.9 | 52 |
| RR06-20-27 | 29.6 | 23.1 | 347 | 43.9 | 50 |
| RR06-20-28 | 29.8 | 23.2 | 378 | 44.4 | 50 |
| Calspan | | St. Dev. | 18.7 | 0.3 | 1.2 |
| | | Average | 368.1 | 44.1 | 51.0 |
| | | %CV | 5.1 | 0.7 | 2.3 |
| UFSSA120 | 29.8 | 21.4 | 466 | 45.1 | 53 |
| MCW | | | | | |
| FR_RR1_36 | 29.5 | 21.2 | 359 | 44.0 | 45 |
| TRC | | | | | |
| All Tests | | St. Dev. | 46.7 | 0.5 | 3.3 |
| | | Average | 385.9 | 44.3 | 50.1 |
| | | %CV | 12.1 | 1.1 | 6.7 |
| | | SigmaL | 13.1 | | |

Cosco Scenera Next - HIII 3YO - RF - LA Only

| Test Number | Sled Velocity (mph) | Test Acceleration (g) | HIC36 | Chest Clip 3ms (g) | RF Angle |
|-------------|---------------------|-----------------------|-------|--------------------|----------|
| RR02-20-09 | 30.0 | 23.2 | 394 | 42.7 | 66 |

| | | | | | |
|-------------|------|-----------------|-------|------|------|
| RR02-20-10 | 29.7 | 23.0 | 376 | 40.6 | 64 |
| RR02-20-11 | 29.7 | 23.0 | 386 | 39.7 | 67 |
| Calspan | | St. Dev. | 9.4 | 1.5 | 1.3 |
| | | Average | 385.4 | 41.0 | 65.6 |
| | | %CV | 2.4 | 3.7 | 2.0 |
| UFSSA201 | 29.5 | 21.7 | 382 | 41.3 | 65 |
| UFSSA202 | 29.4 | 21.6 | 386 | 42.2 | 66 |
| UFSSA203 | 29.3 | 21.8 | 375 | 40.2 | 65 |
| MCW | | St. Dev. | 5.8 | 1.0 | 0.6 |
| | | Average | 381.1 | 41.2 | 65.5 |
| | | %CV | 1.5 | 2.4 | 0.9 |
| FR_RR_PE_08 | 29.4 | 21.2 | 328 | 41.1 | 66 |
| FR_RR_PE_10 | 29.4 | 21.2 | 342 | 42.5 | 63 |
| FR_RR_PE_12 | 29.3 | 21.2 | 392 | 43.7 | 64 |
| TRC | | St. Dev. | 33.7 | 1.3 | 1.6 |
| | | Average | 354.0 | 42.4 | 64.3 |
| | | %CV | 9.5 | 3.1 | 2.4 |
| All Tests | | St. Dev. | 23.0 | 1.3 | 1.2 |
| | | Average | 373.5 | 41.6 | 65.2 |
| | | %CV | 6.2 | 3.1 | 1.9 |

| Graco MyRide 65 - HIII 3YO - RF – Type 2 | | | | | |
|---|----------------------------|------------------------------|--------------|---------------------------|-----------------|
| Test Number | Sled Velocity (mph) | Test Acceleration (g) | HIC36 | Chest Clip 3ms (g) | RF Angle |
| RR06-19-25 | 29.7 | 23.2 | 558 | 51.0 | 52 |
| RR06-19-26 | 29.7 | 23.3 | 523 | 49.3 | 53 |
| RR06-19-27 | 29.9 | 23.4 | 531 | 50.0 | 53 |
| Calspan | | St. Dev. | 18.5 | 0.9 | 0.6 |
| | | Average | 537.4 | 50.1 | 52.8 |
| | | %CV | 3.4 | 1.7 | 1.1 |
| UFSSA_111 | 29.8 | 21.3 | 432 | 47.4 | 61 |
| UFSSA_112 | 29.8 | 21.4 | 451 | 49.9 | 60 |
| UFSSA_113 | 29.7 | 21.2 | 459 | 49.7 | 61 |
| MCW | | St. Dev. | 13.6 | 1.4 | 0.6 |
| | | Average | 447.5 | 49.0 | 60.5 |
| | | %CV | 3.0 | 2.9 | 1.0 |
| FR_RR1_02 | 29.5 | 21.2 | 475 | 48.5 | 62 |
| FR_RR1_04 | 29.5 | 21.1 | 494 | 48.8 | 54 |
| FR_RR1_06 | 29.5 | 21.0 | 494 | 50.2 | 55 |
| TRC | | St. Dev. | 10.9 | 0.9 | 4.3 |
| | | Average | 487.9 | 49.2 | 56.9 |
| | | %CV | 2.2 | 1.9 | 7.5 |
| All Tests | | St. Dev. | 41.0 | 1.1 | 4.0 |
| | | Average | 490.9 | 49.4 | 56.7 |

| | | | | |
|--|------------|-----|-----|-----|
| | %CV | 8.3 | 2.2 | 7.0 |
|--|------------|-----|-----|-----|

| Cosco Scenera Next - HIII 3YO - FF – LATCH | | | | | | |
|---|----------------------------|------------------------------|--------------|---------------------------|----------------------------|----------------------------|
| Test Number | Sled Velocity (mph) | Test Acceleration (g) | HIC36 | Chest Clip 3ms (g) | Head Excursion (mm) | Knee Excursion (mm) |
| UFSSA139 | 30.0 | 21.3 | 382 | 36.9 | 603 | NA |
| UFSSA140 | 30.0 | 21.3 | 432 | 37.3 | 618 | 647 |
| UFSSA141 | 30.0 | 21.3 | 449 | 37.9 | 628 | 650 |
| MCW | | St. Dev. | 35.0 | 0.5 | 12.8 | 2.2 |
| | | Average | 420.9 | 37.4 | 616.3 | 648.5 |
| | | %CV | 8.3 | 1.3 | 2.1 | 0.3 |
| FR_RR1_37 | 29.7 | 21.4 | 363 | 38.9 | 593 | NA |
| FR_RR1_38 | 29.6 | 21.3 | 384 | 40.4 | 591 | NA |
| FR_RR1_39 | 29.6 | 21.2 | 369 | 40.8 | 594 | NA |
| TRC | | St. Dev. | 10.8 | 1.0 | 1.4 | |
| | | Average | 372.0 | 40.1 | 592.6 | |
| | | %CV | 2.9 | 2.5 | 0.2 | |
| All Tests | | St. Dev. | 35.4 | 1.6 | 15.4 | |
| | | Average | 396.5 | 38.7 | 604.5 | |
| | | %CV | 8.9 | 4.2 | 2.5 | |

| Harmony Defender 360 - HIII 3YO - FF – Type 2&T | | | | | | |
|--|----------------------------|------------------------------|--------------|---------------------------|----------------------------|----------------------------|
| Test Number | Sled Velocity (mph) | Test Acceleration (g) | HIC36 | Chest Clip 3ms (g) | Head Excursion (mm) | Knee Excursion (mm) |
| RR02-20-08 | 29.9 | 23.1 | 499 | 49.1 | 593 | NA |
| Calspan | | | | | | |
| UFSSA142 | 30.1 | 21.3 | 328 | 44.3 | 579 | 689 |
| UFSSA143 | 30.1 | 21.3 | 347 | 45.6 | 569 | 684 |
| UFSSA144 | 30.0 | 21.2 | 343 | 43.3 | 568 | 682 |
| MCW | | St. Dev. | 10.5 | 1.2 | 5.9 | 3.5 |
| | | Average | 339.4 | 44.4 | 572.2 | 685.1 |
| | | %CV | 3.1 | 2.6 | 1.0 | 0.5 |
| FR_RR_PE_02 | 29.2 | 21.2 | 400 | 42.8 | 560 | 660 |
| FR_RR_PE_06 | 29.3 | 21.2 | 373 | 41.8 | 570 | 674 |
| TRC | | | | | | |
| All Tests | | St. Dev. | 62.9 | 2.6 | 11.4 | 11.1 |
| | | Average | 381.7 | 44.5 | 573.3 | 678.0 |
| | | %CV | 16.5 | 5.9 | 2.0 | 1.6 |
| | | SigmaL | 9.8 | | | |

| Britax Marathon Clicktight- HIII 6YO - FF – LA Only | | | | | | |
|--|----------------------------|------------------------------|--------------|---------------------------|----------------------------|----------------------------|
| Test Number | Sled Velocity (mph) | Test Acceleration (g) | HIC36 | Chest Clip 3ms (g) | Head Excursion (mm) | Knee Excursion (mm) |
| RR06-19-38 | 29.6 | 23.3 | 652 | 40.6 | 775 | 859 |
| RR02-20-01 | 29.9 | 23.3 | 708 | 40.8 | 828 | 880 |
| RR02-20-02 | 29.9 | 23.3 | 741 | 44.4 | 801 | 869 |
| Calspan | | St. Dev. | 45.4 | 2.1 | 26.6 | 10.5 |
| | | Average | 700.3 | 41.9 | 801.2 | 869.4 |
| | | %CV | 6.5 | 5.1 | 3.3 | 1.2 |
| UFSSA138 | 29.9 | 21.2 | 771 | 43.8 | 764 | 819 |
| MCW | | | | | | |
| FR_RR1_31 | 29.4 | 21.2 | 697 | 46.7 | 808 | 876 |
| TRC | | | | | | |
| All Tests | | St. Dev. | 45.2 | 2.6 | 25.9 | 24.7 |
| | | Average | 713.8 | 43.3 | 795.2 | 860.7 |
| | | %CV | 6.3 | 6.0 | 3.3 | 2.9 |

| Evenflo SureRide - HIII 6YO - FF – LATCH | | | | | | |
|---|----------------------------|------------------------------|--------------|---------------------------|----------------------------|----------------------------|
| Test Number | Sled Velocity (mph) | Test Acceleration (g) | HIC36 | Chest Clip 3ms (g) | Head Excursion (mm) | Knee Excursion (mm) |
| UFSSA129 | 29.7 | 21.2 | 359 | 42.4 | 681 | 787 |
| UFSSA130 | 29.9 | 21.2 | 434 | 45.0 | 635 | 785 |
| UFSSA131 | 29.8 | 21.2 | 373 | 45.1 | 664 | 791 |
| MCW | | St. Dev. | 40.0 | 1.5 | 23.4 | 3.1 |
| | | Average | 389.0 | 44.2 | 660.0 | 787.6 |
| | | %CV | 10.3 | 3.4 | 3.5 | 0.4 |
| FR_RR1_25 | 29.4 | 21.1 | 366 | 42.7 | 649 | 773 |
| FR_RR1_27 | 29.4 | 21.0 | 334 | 42.6 | 648 | 772 |
| FR_RR1_29 | 29.5 | 21.2 | 359 | 42.9 | 638 | 765 |
| TRC | | St. Dev. | 17.1 | 0.1 | 6.2 | 4.6 |
| | | Average | 353.1 | 42.7 | 644.7 | 770.0 |
| | | %CV | 4.8 | 0.3 | 1.0 | 0.6 |
| All Tests | | St. Dev. | 33.8 | 1.2 | 17.5 | 10.2 |
| | | Average | 371.0 | 43.4 | 652.4 | 778.8 |
| | | %CV | 9.1 | 2.9 | 2.7 | 1.3 |

| Graco Nautilus 65 - HIII 6YO - FF - Type 2 | | | | | | |
|---|----------------------------|------------------------------|--------------|---------------------------|----------------------------|----------------------------|
| Test Number | Sled Velocity (mph) | Test Acceleration (g) | HIC36 | Chest Clip 3ms (g) | Head Excursion (mm) | Knee Excursion (mm) |

| | | | | | | |
|------------|------|-----------------|-------|------|-------|-------|
| RR04-19-01 | 29.4 | 22.8 | 456 | 44.6 | 648 | 732 |
| RR04-19-04 | 30.1 | 23.3 | 490 | 45.6 | 669 | 732 |
| RR05-19-09 | 29.8 | 23.5 | 474 | 45.7 | 666 | 742 |
| Calspan | | St. Dev. | 16.8 | 0.6 | 11.5 | 5.4 |
| | | Average | 473.4 | 45.3 | 660.8 | 735.4 |
| | | %CV | 3.5 | 1.3 | 1.7 | 0.7 |
| UFSSA_105 | 29.7 | 21.2 | 534 | 41.1 | 672 | 732 |
| UFSSA_106 | 29.8 | 21.4 | 587 | 44.3 | 675 | 742 |
| UFSSA_110 | 29.9 | 21.3 | 548 | 45.5 | 666 | 735 |
| MCW | | St. Dev. | 27.5 | 2.3 | 4.6 | 5.2 |
| | | Average | 556.4 | 43.6 | 671.2 | 736.1 |
| | | %CV | 4.9 | 5.2 | 0.7 | 0.7 |
| FR_RR1_01 | 29.5 | 21.2 | 565 | 44.9 | 690 | 751 |
| FR_RR1_03 | 29.5 | 21.1 | 550 | 46.6 | 676 | 737 |
| FR_RR1_05 | 29.5 | 21.0 | 574 | 45.9 | 692 | 752 |
| TRC | | St. Dev. | 12.2 | 0.9 | 8.4 | 8.5 |
| | | Average | 562.8 | 45.8 | 685.9 | 746.5 |
| | | %CV | 2.2 | 1.9 | 1.2 | 1.1 |
| All Tests | | St. Dev. | 46.5 | 1.6 | 13.2 | 7.8 |
| | | Average | 530.9 | 44.9 | 672.6 | 739.3 |
| | | %CV | 8.8 | 3.5 | 2.0 | 1.1 |

| Cosco Pronto HB - HIII 6YO - BPSB – Type 2 | | | | | | |
|---|----------------------------|------------------------------|--------------|---------------------------|----------------------------|----------------------------|
| Test Number | Sled Velocity (mph) | Test Acceleration (g) | HIC36 | Chest Clip 3ms (g) | Head Excursion (mm) | Knee Excursion (mm) |
| RR05-19-13 | 29.9 | 23.3 | 650 | 58.7 | 528 | 613 |
| RR05-19-14 | 29.9 | 23.3 | 621 | 51.9 | 525 | 605 |
| RR05-19-15 | 29.9 | 23.3 | 663 | 52.5 | 533 | 613 |
| Calspan | | St. Dev. | 21.6 | 3.8 | 4.3 | 4.3 |
| | | Average | 645.1 | 54.4 | 528.7 | 610.1 |
| | | %CV | 3.4 | 7.0 | 0.8 | 0.7 |
| UFSSA135 | 29.9 | 21.1 | 550 | 49.8 | 551 | 593 |
| UFSSA136 | 30.0 | 21.2 | 604 | 47.0 | 517 | 600 |
| UFSSA137 | 29.9 | 21.2 | 534 | 44.7 | 527 | 594 |
| MCW | | St. Dev. | 36.6 | 2.5 | 17.9 | 3.8 |
| | | Average | 562.7 | 47.2 | 531.6 | 595.4 |
| | | %CV | 6.5 | 5.4 | 3.4 | 0.6 |
| FR_RR1_19 | 29.2 | 20.7 | 573 | 45.4 | 566 | 617 |
| FR_RR1_21 | 29.3 | 20.8 | 606 | 45.3 | 568 | 619 |
| FR_RR1_23 | 29.4 | 20.9 | 566 | 46.2 | 564 | 611 |
| TRC | | St. Dev. | 21.1 | 0.5 | 2.1 | 4.4 |
| | | Average | 581.5 | 45.6 | 565.8 | 615.7 |
| | | %CV | 3.6 | 1.0 | 0.4 | 0.7 |
| All Tests | | St. Dev. | 44.3 | 4.7 | 20.1 | 9.8 |

| | | | | | |
|--|----------------|-------|------|-------|-------|
| | Average | 596.4 | 49.1 | 542.0 | 607.0 |
| | %CV | 7.4 | 9.5 | 3.7 | 1.6 |

| Graco Affix -HIII6YO BPS -Type 2 | | | | | | |
|---|----------------------------|------------------------------|--------------|---------------------------|----------------------------|----------------------------|
| Test Number | Sled Velocity (mph) | Test Acceleration (g) | HIC36 | Chest Clip 3ms (g) | Head Excursion (mm) | Knee Excursion (mm) |
| RR04-19-05 | 29.5 | 23.0 | 457 | 52.3 | 463 | 602 |
| RR06-20-38 | 29.9 | 23.1 | 498 | 52.7 | 477 | 602 |
| RR06-20-39 | 29.9 | 23.1 | 464 | 50.7 | 474 | 605 |
| Calspan | | St. Dev. | 22.2 | 1.0 | 7.5 | 1.5 |
| | | Average | 473.2 | 51.9 | 471.0 | 603.0 |
| | | %CV | 4.7 | 2.0 | 1.6 | 0.2 |
| UFSSA132 | 29.9 | 21.1 | 519 | 48.0 | 475 | 587 |
| UFSSA133 | 30.0 | 21.1 | 578 | 52.9 | 460 | 559 |
| UFSSA134 | 30.1 | 21.1 | 563 | 52.5 | 486 | 598 |
| MCW | | St. Dev. | 30.5 | 2.7 | 12.9 | 20.5 |
| | | Average | 553.0 | 51.1 | 473.5 | 581.4 |
| | | %CV | 5.5 | 5.2 | 2.7 | 3.5 |
| FR_RR1_13 | 29.3 | 20.8 | 485 | 53.9 | 482 | 591 |
| FR_RR1_15 | 29.4 | 20.9 | 459 | 52.7 | 482 | 592 |
| FR_RR1_17 | 29.4 | 20.8 | 537 | 53.8 | 501 | 596 |
| TRC | | St. Dev. | 40.0 | 0.7 | 11.1 | 2.4 |
| | | Average | 493.8 | 53.5 | 488.3 | 593.0 |
| | | %CV | 8.1 | 1.2 | 2.3 | 0.4 |
| All Tests | | St. Dev. | 45.2 | 1.8 | 12.3 | 14.0 |
| | | Average | 506.7 | 52.2 | 477.6 | 592.4 |
| | | %CV | 8.9 | 3.5 | 2.6 | 2.4 |

| Harmony Youth NB - HIII 6YO - BPS - Type 2 | | | | | | |
|---|----------------------------|------------------------------|--------------|---------------------------|----------------------------|----------------------------|
| Test Number | Sled Velocity (mph) | Test Acceleration (g) | HIC36 | Chest Clip 3ms (g) | Head Excursion (mm) | Knee Excursion (mm) |
| RR04-19-06 | 29.6 | 23.1 | 489 | 50.6 | 462 | 600 |
| RR04-19-07 | 29.8 | 23.4 | 460 | 49.3 | 463 | 584 |
| RR05-19-08 | 29.8 | 23.3 | 463 | 49.4 | 453 | 579 |
| Calspan | | St. Dev. | 16.0 | 0.7 | 5.2 | 10.7 |
| | | Average | 470.2 | 49.8 | 459.2 | 587.5 |
| | | %CV | 3.4 | 1.4 | 1.1 | 1.8 |
| UFSSA_107 | 29.7 | 21.3 | 493 | 49.5 | 468 | 578 |
| UFSSA_108 | 29.8 | 21.2 | 529 | 50.0 | 475 | 587 |
| UFSSA_109 | 29.6 | 21.2 | 536 | 51.2 | 476 | 587 |
| MCW | | St. Dev. | 23.2 | 0.8 | 4.5 | 5.1 |
| | | Average | 519.2 | 50.2 | 473.1 | 583.9 |

| | | | | | | |
|-----------|------|-----------------|-------|------|-------|-------|
| | | %CV | 4.5 | 1.7 | 1.0 | 0.9 |
| FR_RR1_07 | 29.2 | 20.8 | 409 | 46.3 | 476 | 579 |
| FR_RR1_09 | 29.3 | 21.0 | 476 | 48.7 | 455 | 590 |
| FR_RR1_11 | 29.2 | 21.0 | 489 | 48.4 | 468 | 585 |
| TRC | | St. Dev. | 43.3 | 1.3 | 10.8 | 5.3 |
| | | Average | 458.2 | 47.8 | 466.2 | 584.7 |
| | | %CV | 9.4 | 2.7 | 2.3 | 0.9 |
| All Tests | | St. Dev. | 38.1 | 1.4 | 8.8 | 6.7 |
| | | Average | 482.6 | 49.3 | 466.2 | 585.4 |
| | | %CV | 7.9 | 2.9 | 1.9 | 1.1 |

| Britax Frontier Clicktight - HIII 10YO - FF - Type 2&T | | | | | | |
|---|---------------------|-----------------------|-------|--------------------|---------------------|---------------------|
| Test Number | Sled Velocity (mph) | Test Acceleration (g) | HIC36 | Chest Clip 3ms (g) | Head Excursion (mm) | Knee Excursion (mm) |
| RR05-19-20 | 29.8 | 23.4 | n/a | 38.5 | 701 | 817 |
| RR05-19-21 | 29.8 | 23.4 | n/a | 43.6 | 701 | 840 |
| Calspan | | | | | | |
| UFSSA128 | 29.9 | 21.4 | n/a | 37.6 | 706 | 840 |
| MCW | | | | | | |
| FR_RR1_08 | 29.2 | 20.8 | n/a | 41.3 | 714 | 825 |
| FR_RR1_10 | 29.3 | 21.0 | n/a | 42.3 | 729 | 816 |
| FR_RR1_12 | 29.2 | 21.0 | n/a | 38.3 | 720 | 822 |
| TRC | | St. Dev. | n/a | 2.1 | 7.2 | 4.4 |
| | | Average | n/a | 40.6 | 721.1 | 820.9 |
| | | %CV | n/a | 5.1 | 1.0 | 0.5 |
| All Tests | | St. Dev. | n/a | 2.5 | 11.3 | 10.7 |
| | | Average | n/a | 40.2 | 711.9 | 826.6 |
| | | %CV | n/a | 6.1 | 1.6 | 1.3 |

| Evenflo Big Kid LX HB - HIII 10YO - BPS - Type 2 | | | | | | |
|---|---------------------|-----------------------|-------|--------------------|---------------------|---------------------|
| Test Number | Sled Velocity (mph) | Test Acceleration (g) | HIC36 | Chest Clip 3ms (g) | Head Excursion (mm) | Knee Excursion (mm) |
| RR05-19-16 | 29.8 | 23.2 | n/a | 43.3 | 525 | 693 |
| RR05-19-17 | 29.9 | 23.3 | n/a | 42.6 | 518 | 644 |
| RR05-19-18 | 29.7 | 23.1 | n/a | 44.0 | 515 | 690 |
| Calspan | | St. Dev. | n/a | 0.7 | 5.6 | 27.4 |
| | | Average | n/a | 43.3 | 519.2 | 675.6 |
| | | %CV | n/a | 1.6 | 1.1 | 4.1 |
| UFSSA121 | 29.6 | 21.0 | n/a | 45.7 | 560 | 709 |
| UFSSA122 | 29.7 | 21.1 | n/a | 47.0 | 540 | 712 |
| UFSSA123 | 29.7 | 21.2 | n/a | 43.9 | 549 | 696 |
| MCW | | St. Dev. | n/a | 1.6 | 9.9 | 8.5 |

| | | | | | | |
|-----------|------|-----------------|-----|------|-------|-------|
| | | Average | n/a | 45.6 | 549.7 | 705.3 |
| | | %CV | n/a | 3.5 | 1.8 | 1.2 |
| FR_RR1_14 | 29.3 | 20.8 | n/a | 42.5 | 557 | 671 |
| FR_RR1_16 | 29.4 | 20.9 | n/a | 43.2 | 562 | 669 |
| FR_RR1_18 | 29.4 | 20.8 | n/a | 43.3 | 556 | 671 |
| TRC | | St. Dev. | n/a | 0.4 | 3.3 | 1.0 |
| | | Average | n/a | 43.0 | 558.4 | 670.6 |
| | | %CV | n/a | 1.0 | 0.6 | 0.1 |
| All Tests | | St. Dev. | n/a | 1.5 | 18.8 | 21.7 |
| | | Average | n/a | 44.0 | 542.5 | 683.8 |
| | | %CV | n/a | 3.4 | 3.5 | 3.2 |

Appendix B to the Preamble: Repeatability Test Results

| Cosco Scenera Next – Rear-facing- 12-Month-Old – Lower Anchor Only Installation | | | | | |
|--|---------------------|-----------------------|-------|--------------------|----------|
| Test Number | Sled Velocity (mph) | Test Acceleration (g) | HIC36 | Chest Clip 3ms (g) | RF Angle |
| RR02-20-15 | 29.7 | 23.0 | 329 | 42.5 | 57 |
| RR02-20-16 | 29.8 | 23.1 | 336 | 42.1 | 59 |
| RR02-20-17 | 29.8 | 23.1 | 305 | 37.7 | 61 |
| Calspan | | St. Dev. | 16.0 | 2.7 | 1.9 |
| | | Average | 323.2 | 40.7 | 59.1 |
| | | %CV | 5.0 | 6.6 | 3.3 |

| Maxi Cosi Pria HIII-10-Year-Old Forward-facing CRS – Type 2 Belt Installation | | | | | | |
|--|---------------------|-----------------------|-------|--------------------|---------------------|---------------------|
| Test Number | Sled Velocity (mph) | Test Acceleration (g) | HIC36 | Chest Clip 3ms (g) | Head Excursion (mm) | Knee Excursion (mm) |
| RR02-20-21 | 29.9 | 23.5 | n/a | 48.3 | 747 | 798 |
| RR02-20-22 | 29.9 | 23.4 | n/a | 48.8 | 741 | 796 |
| RR02-20-23 | 29.8 | 23.2 | n/a | 45.3 | 735 | 781 |
| Calspan | | St. Dev. | n/a | 1.9 | 5.7 | 9.3 |
| | | Average | n/a | 47.5 | 741.0 | 791.7 |
| | | %CV | n/a | 3.9 | 0.8 | 1.2 |

| Harmony Youth HIII-10-Year-Old – Belt- Positioning Seat – Type 2 Belt Installation | | | | | | |
|---|---------------------|-----------------------|-------|--------------------|---------------------|---------------------|
| Test Number | Sled Velocity (mph) | Test Acceleration (g) | HIC36 | Chest Clip 3ms (g) | Head Excursion (mm) | Knee Excursion (mm) |
| FR_RR_PE_1 | 29.2 | 21.2 | n/a | 42.8 | 497 | 688 |
| FR_RR_PE_3 | 29.3 | 21.2 | n/a | 43.5 | 483 | 675 |
| FR_RR_PE_5 | 29.3 | 21.2 | n/a | 43.2 | 481 | 676 |
| TRC | | St. Dev. | n/a | 0.4 | 9.1 | 7.0 |
| | | Average | n/a | 43.2 | 486.9 | 679.7 |
| | | %CV | n/a | 0.9 | 1.9 | 1.0 |

List of Subjects in 49 CFR Part 571

Imports, Incorporation by Reference, Motor vehicle safety, Motor vehicles, and Tires.

In consideration of the foregoing, NHTSA amends 49 CFR part 571 as set forth below.

PART 571 - - FEDERAL MOTOR VEHICLE SAFETY STANDARDS

1. The authority citation for part 571 continues to read as follows:

Authority: 49 U.S.C. 322, 30111, 30115, 30117 and 30166; delegation of authority at 49 CFR 1.95.

2. Section 571.5 is amended by:

- a. Adding paragraph (b)(3);
- b. Revising paragraph (d)(16);
- c. Redesignating paragraphs (d)(22) through (38) as paragraphs (d)(23) through (39);
- d. Adding new paragraph (d)(22) and paragraphs (k)(6) and (7); and
- e. Revising paragraphs (l)(3) and (4).

The additions and revisions read as follows:

§571.5 Matter incorporated by reference.

* * * * *

(b) * * *

(3) AATCC Evaluation Procedure (EP) 1-2007, Gray Scale for Color Change, reaffirmed 2007; into §571.213b.

* * * * *

(d) * * *

(16) ASTM D1056-07, *Standard Specification for Flexible Cellular Materials-Sponge or Expanded Rubber*, approved March 1, 2007; into §§571.213; 571.213b.

* * * * *

(22) ASTM D3574-11, *Standard Test Methods for Flexible Cellular Materials—Slab, Bonded, and Molded Urethane Foams*, approved December 1, 2011; into §571.213b.

* * * * *

(k) * * *

(6) NHTSA Standard Seat Assembly; FMVSS No. 213, No. NHTSA-213-2021, *Parts List and Drawings, NHTSA Standard Seat Assembly; FMVSS No. 213, No. NHTSA-213-2021, Child Frontal Impact Sled*, March 2023; into §571.213b.

(7) Drawing No. 210-5000-1 (L), -2(R), Leg Assembly, *Parts List and Drawings, Subpart P Hybrid III 3-year-old child crash test dummy, (H-III3C, Alpha version)*, September 2001, Drawing No. 210-5000-1(L), -2(R), Leg Assembly; into §571.213b.

(l) * * *

(3) SAE Recommended Practice J211, *Instrumentation for Impact Tests*, revised June 1980; into §571.218.

(4) SAE Recommended Practice J211/1, *Instrumentation for Impact Tests—Part 1—Electronic Instrumentation*; revised March 1995; §§571.202a; 571.208; 571.213; 571.213a; 571.213b; 571.218; 571.403.

* * * * *

3. Section 571.213 is amended by

a. Revising the section heading and S3;

b. Adding in alphabetical order a definition for “school bus child restraint system” to S4;

c. Revising the table to S5.1.3.1(a) and adding table 2 to S5.1.3.1(a);

d. Revising the introductory text to S5.3.1(b);

e. Adding S5.3.1(c) and S5.3.2.1;

f. Revising S5.5.2(f) and S5.5.2(g)(1)(i);

g. Removing and reserving S5.5.2(l)(2),

- h. Revising the introductory text of S5.5.2(1)(3)(i), and S5.6.1.7; S5.6.1.11, S5.6.2.2, and S5.8.1(a);
- i. Adding section S5.8.1.1;
- j. Revising the introductory text of S5.8.2(a);
- k. Adding section S5.8.2.1;
- l. Revising S5.9(a), S6.1.1(a)(2)(i)(B), S6.1.1(a)(2)(ii)(G), S6.1.2(a)(1)(i)(B), and the introductory text of S10.2.3; and,
- m. Adding figures 9a-2 and 9b-2 in alphanumeric order.

The revisions and additions read as follows:

§571.213 Child restraint systems; Applicable unless a vehicle or child restraint system is certified to § 571.213b.

* * * * *

S3. Application. This standard applies to passenger cars, multipurpose passenger vehicles, trucks and buses, and to child restraint systems for use in motor vehicles and aircraft, manufactured before December 5, 2026. FMVSS No. 213b applies to child restraint systems manufactured on or after December 5, 2026.

S4. Definitions

* * *

School bus child restraint system means an add-on child restraint system (including a harness) manufactured and sold only for use on school bus seats, that has a label conforming with S5.3.1(b). (This definition applies to child restraint systems manufactured on or after December 5, 2024.)

* * * * *

Table 1 to S5.1.3.1(a)—Add-On Child Restraints that Can be Used Forward-Facing Manufactured Before December 5, 2024

| When this type of child restraint | Is tested in accordance with— | These excursion limits apply | Explanatory note: in the test specified in 2nd column, the child restraint is attached to the test seat assembly in the manner described below, subject to certain conditions |
|--|--|-------------------------------------|--|
| Harnesses and restraints designed for use by children with physical disabilities | S6.1.2(a)(1)(i)(A) | Head 813 mm; Knee 915 mm. | Attached with lap belt; in addition, if a tether is provided, it is attached. |
| Harnesses labeled per S5.3.1(b)(i) through S5.3.1(b)(iii) and Figure 12. | S6.1.2(a)(1)(i)(A) | Head 813 mm; Knee 915 mm | Attached with seat back mount. |
| Belt-positioning seats | S6.1.2(a)(1)(ii) | Head 813 mm; Knee 915 mm | Attached with lap and shoulder belt; no tether is attached. |
| All other child restraints (i.e., other than harnesses, restraints designed for use by children with physical disabilities, harnesses manufactured exclusively for school buses, and belt-positioning seats) | S6.1.2(a)(1)(i)(B) | Head 813 mm; Knee 915 mm | Attached with a lap belt, without a tether attached; and, Attached to lower anchorages of a child restraint anchorage system; no tether is attached. |
| All other child restraints (i.e., other than harnesses, restraints designed for use by children with physical disabilities, harnesses labeled per S5.3.1(b)(i) through S5.3.1(b)(iii) and | S6.1.2(a)(1)(i)(A), S6.1.2(a)(1)(i)(C) | Head 720 mm; Knee 915 mm | Attached with a lap belt, with a tether attached; and, Attached to lower anchorages of child restraint anchorage system, with a tether attached. |

| | | | |
|--|--------------------------------------|-------------------------------------|--|
| When this type of child restraint | Is tested in accordance with— | These excursion limits apply | Explanatory note: in the test specified in 2nd column, the child restraint is attached to the test seat assembly in the manner described below, subject to certain conditions |
| Figure 12, and belt-positioning seats) | | | |

Table 2 to S5.1.3.1(a)—Add-On Child Restraints that Can be Used Forward-Facing Manufactured On or After December 5, 2024

| | | | |
|--|--|-------------------------------------|--|
| When this type of child restraint | Is tested in accordance with— | These excursion limits apply | Explanatory note: in the test specified in 2nd column, the excursion requirement must be met when the child restraint system is attached to the test seat assembly in the manner described below, subject to certain conditions |
| Harnesses and restraints designed for use by children with physical disabilities | S6.1.2(a)(1)(i)(A) | Head 813 mm; Knee 915 mm. | Attached with lap and shoulder belt; in addition, if a tether is provided, it is attached. |
| School bus child restraint systems | S6.1.2(a)(1)(i)(A) | Head 813 mm; Knee 915 mm | Attached with seat back mount, or, seat back, and, seat pan mounts. |
| Booster seats | S6.1.2(a)(1)(ii) | Head 813 mm; Knee 915 mm | Attached with lap and shoulder belt; no tether is attached. |
| Child restraints other than harnesses, restraints designed for use by children with physical disabilities, school bus child restraint systems, and booster seats | S6.1.2(a)(1)(i)(B) | Head 813 mm; Knee 915 mm | Attached with a lap belt; without a tether attached. Attached to lower anchorages of child restraint anchorage system; with no tether attached. |
| Child restraints other than harnesses, | S6.1.2(a)(1)(i)(A), S6.1.2(a)(1)(i)(C) | Head 720 mm; Knee 915 mm | Attached with a lap belt, with a tether attached. |

| When this type of child restraint | Is tested in accordance with— | These excursion limits apply | Explanatory note: in the test specified in 2nd column, the excursion requirement must be met when the child restraint system is attached to the test seat assembly in the manner described below, subject to certain conditions |
|---|-------------------------------|------------------------------|--|
| restraints designed for use by children with physical disabilities, and school bus child restraint systems | | | Attached to lower anchorages of child restraint anchorage system, with a tether attached. |
| Child restraints equipped with a fixed or movable surface described in S5.2.2.2 that has belts that are not an integral part of that fixed or movable surface | S6.1.2(a)(2) | Head 813 mm; Knee 915 mm | Attached with lap belt, no tether is attached. |

* * * * *

S5.3.1 * * *

(b) School bus child restraint systems (including harnesses manufactured for use on school bus seats) must have a label that conforms in content to Figure 12 and to the requirements of S5.3.1(b)(1) through S5.3.1(b)(3) of this standard. The label must be permanently affixed to the part of the school bus child restraint system, that attaches the system to a vehicle seat back.

* * * * *

(c) The provision that add-on child restraint systems shall meet the requirements of this standard when installed solely by a Type 1 belt applies to child restraint systems manufactured before September 1, 2029. Except for harnesses, the requirement sunsets for child restraint systems manufactured on or after September 1, 2029. For harnesses, the requirement does not sunset and continues to apply to harnesses manufactured on or after September 1, 2029.

* * * * *

S5.3.2.1 School bus child restraint systems manufactured on or after December 5, 2024, shall be capable of meeting the requirements of this standard when installed by seat back mount, or, seat back mount and seat pan mount.

* * * * *

S5.5.2 * * *

(f) For child restraint systems manufactured before December 5, 2024, paragraph (f)(1) of this section applies. For child restraint systems manufactured on or after December 5, 2024, paragraph (f)(2) of this section applies.

(1) One of the following statements, as appropriate, inserting the manufacturer's recommendations for the maximum mass of children who can safely occupy the system, except that booster seats shall not be recommended for children whose masses are less than 13.6 kg. For child restraint systems that can only be used as belt-positioning seats, manufacturers must include the maximum and minimum recommended height, but may delete the reference to weight:

(i) Use only with children who weigh ____ pounds (____ kg) or less and whose height is *(insert values in English and metric units; use of word "mass" in label is optional)* or less; or

(ii) Use only with children who weigh between ____ and ____ pounds *(insert appropriate English and metric values; use of word "mass" is optional)* and whose height is *(insert appropriate values in English and metric units)* or less and who are capable of sitting upright alone; or

(iii) Use only with children who weigh between ____ and ____ pounds *(insert appropriate English and metric values; use of word "mass" is optional)* and whose height is *(insert appropriate values in English and metric units)* or less.

(iv) Use only with children who weigh between ____ and ____ pounds (*insert appropriate English and metric values; use of word “mass” is optional*) and whose height is between ____ and ____ (*insert appropriate values in English and metric units*).

(2) For child restraint systems manufactured on or after December 5, 2024: Statements or a combination of statements and pictograms specifying the manufacturer's recommendations for the mass and height ranges (in English and metric units) of children who can safely occupy the system in each applicable mode (rear-facing, forward-facing, booster), except manufacturers shall not recommend forward-facing use for child restraint systems with internal harnesses for children of masses less than 12 kg (26.5 lb), and shall not recommend booster seats for children of masses less than 18.4 kg (40 lb).

(g) * * *

(1) * * *

(i) As appropriate, the statements required by the following sections will be bulleted and placed after the statement required by 5.5.2(g)(1) in the following order: 5.5.2(k)(1), 5.5.2(h), 5.5.2(j), and 5.5.2(i). For child restraint systems manufactured on or after December 5, 2024, the statements required by 5.5.2(f) and 5.5.2(k)(2) need not be included.

* * * * *

(1) * * *

(3) * * *

(i) If the child restraint system is designed to meet the requirements of this standard when installed by the child restraint anchorage system according to S5.3.2, and if the sum of the weight of the child restraint system and the maximum child weight recommended for the child restraint when used with the restraint's internal harness or components is greater than 65 lb when used forward-facing or rear-facing, include the following statement on this installation diagram: “Do not install by this method for a child weighing more than *.” At the manufacturer's option, “*” is the child weight limit in English units in accordance with S5.5.2(1)(3)(i)(A), (B) or (C).

The corresponding child weight limit in metric units may also be included in the statement at the manufacturer's option.

* * * * *

S5.6.1.7(a) For child restraint systems manufactured before December 5, 2024, one of the following statements, inserting an address and a U.S. telephone number. If a manufacturer opts to provide a Web site on the registration card as permitted in Figure 9a of this section, the manufacturer must include the statement in paragraph S5.6.1.7(a)(2):

(1) “Child restraints could be recalled for safety reasons. You must register this restraint to be reached in a recall. Send your name, address, e-mail address if available (preceding four words are optional), and the restraint's model number and manufacturing date to (*insert address*) or call (*insert a U.S. telephone number*). For recall information, call the U.S. Government's Vehicle Safety Hotline at 1-888-327-4236 (TTY: 1-800-424-9153), or go to *www.NHTSA.gov*.”

(2) “Child restraints could be recalled for safety reasons. You must register this restraint to be reached in a recall. Send your name, address, e-mail address if available (preceding four words are optional), and the restraint's model number and manufacturing date to (*insert address*) or call (*insert telephone number*) or register online at (*insert website for electronic registration form*). For recall information, call the U.S. Government's Vehicle Safety Hotline at 1-888-327-4236 (TTY: 1-800-424-9153), or go to *www.NHTSA.gov*.”

(b) For child restraint systems manufactured on or after December 5, 2024, the child restraint system shall include statements informing the owner of the importance of registering the child restraint for recall purposes and instructing the owner how to register the child restraint at least by mail and by telephone, providing a U.S. telephone number. The following statement must also be provided: “For recall information, call the U.S. Government's Vehicle Safety Hotline at 1-888-327-4236 (TTY: 1-800-424-9153), or go to *www.NHTSA.gov*.”

* * * * *

S5.6.1.11(a) For harnesses that are manufactured before December 5, 2024, for use on school bus seats, the instructions must include the following statement:

“WARNING! This restraint must only be used on school bus seats. Entire seat directly behind must be unoccupied or have restrained occupants.” The labeling requirement refers to a restrained occupant as: an occupant restrained by any user appropriate vehicle restraint or child restraint system (*e.g.*, lap belt, lap and shoulder belt, booster, child seat, harness . . .).

(b) For school bus child restraint systems manufactured on or after December 5, 2024, the instructions must include the following statement:

“WARNING! This restraint must only be used on school bus seats. Entire seat directly behind must be unoccupied or have restrained occupants.” (The instruction's reference to a “restrained occupant” refers to an occupant restrained by any user-appropriate vehicle restraint or child restraint system (*e.g.*, lap belt, lap and shoulder belt, booster seat or other child restraint system.)

* * * * *

S5.6.2.2(a) For child restraint systems manufactured before December 5, 2024, the instructions for each built-in child restraint system other than a factory-installed restraint, shall include one of the following statements, inserting an address and a U.S. telephone number. If a manufacturer opts to provide a Web site on the registration card as permitted in Figure 9a of this section, the manufacturer must include the statement in S5.6.2.2(a)(2):

(1) “Child restraints could be recalled for safety reasons. You must register this restraint to be reached in a recall. Send your name, address, e-mail address if available (preceding four words are optional), and the restraint's model number and manufacturing date to (*insert address*) or call (*insert a U.S. telephone number*). For recall information, call the U.S. Government's Vehicle Safety Hotline at 1-888-327-4236 (TTY: 1-800-424-9153), or go to www.NHTSA.gov.”

(2) “Child restraints could be recalled for safety reasons. You must register this restraint to be reached in a recall. Send your name, address, e-mail address if available (preceding four words are optional), and the restraint's model number and manufacturing date to (*insert address*) or call (insert U.S. telephone number) or register online at (*insert website for electronic registration form*). For recall information, call the U.S. Government's Vehicle Safety Hotline at 1-888-327-4236 (TTY: 1-800-424-9153), or go to www.NHTSA.gov.”

(b) For child restraint systems manufactured on or after December 5, 2024, the instructions for each built-in child restraint system other than a factory-installed restraint shall include statements informing the owner of the importance of registering the child restraint for recall purposes and instructing the owner how to register the child restraint at least by mail and by telephone, providing a U.S. telephone number. The following statement must also be provided: “For recall information, call the U.S. Government's Vehicle Safety Hotline at 1-888-327-4236 (TTY: 1-800-424-9153), or go to *www.NHTSA.gov*.”

* * * * *

S5.8.1 * * *

(a) For child restraint systems manufactured before December 5, 2024, each child restraint system, except a factory-installed built-in restraint system, shall have a registration form attached to any surface of the restraint that contacts the dummy when the dummy is positioned in the system in accordance with S6.1.2 of Standard 213.

* * * * *

S5.8.1.1 *Upgraded attached registration form*. For child restraint systems manufactured on or after December 5, 2024, each child restraint system, except a factory-installed built-in restraint system, shall have a registration form attached to any surface of the restraint that contacts the dummy when the dummy is positioned in the system in accordance with S6.1.2 of Standard 213. The form shall not have advertising or any information other than that related to registering the child restraint system.

(a) Each attached registration form shall provide a mail-in postcard that conforms in size, and in basic content and format to the forms depicted in Figures 9a' and 9b' of this section.

(1) The mail-in postcard shall:

(i) Have a thickness of at least 0.007 inches and not more than 0.0095 inches;

(ii) Be pre-printed with the information identifying the child restraint system for recall purposes, such as the model name or number and date of manufacture (month, year) of the child restraint system to which the form is attached;

(iii) Contain space for the owner to record his or her name, mailing address, e-mail address (optional), telephone number (optional), and other pertinent information;

(iv) Be addressed to the manufacturer, and be postage paid.

(v) Be detachable from the information card without the use of scissors or other tools.

(c) The registration form attached to the child restraint system shall also provide an information card with the following:

(1) Informing the owner of the importance of registering the child restraint system; and,

(2) Instructing the owner how to register the CRS.

(3) Manufacturers must provide statements informing the purchaser that the registration card is pre-addressed and that postage has been paid.

(4) Manufacturers may provide instructions to register the child restraint system electronically. If an electronic registration form is used or referenced, it must meet the requirements of S5.8.2 of this section.

(5) Manufacturers may optionally provide statements to the owner explaining that the registration card is not a warranty card, and that the information collected from the owner will not be used for marketing purposes

S5.8.2 * * *

(a) Each electronic registration form provided for child restraint systems manufactured before December 5, 2024, shall:

* * * * *

S5.8.2.1 *Upgraded electronic registration form*

(a) Each electronic registration form provided for child restraint systems manufactured on or after December 5, 2024, shall:

(1) Contain statements at the top of the form:

- (i) Informing the owner of the importance of registering the CRS; and,
- (ii) Instructing the owner how to register the CRS.

(2) Provide as required registration fields, space for the purchaser to record the model name or number and date of manufacture (month, year) of the child restraint system, and space for the purchaser to record his or her name and mailing address. At the manufacturer's option, a space is provided for the purchaser to optionally record his or her e-mail address. At the manufacturer's option, a space is provided for the purchaser to optionally record his or her telephone number.

(b) No advertising or other information shall appear on the electronic registration form. However, manufacturers may optionally provide a statement to the owner explaining that the registration is not a warranty card, and that the information collected from the owner will not be used for marketing purposes.

(c) The electronic registration form may provide information identifying the manufacturer or a link to the manufacturer's home page, a field to confirm submission, and a prompt to indicate any incomplete or invalid fields prior to submission.

(d) If a manufacturer printed the electronic address (in form of a website (printed URL)) on the attached registration form provided pursuant to S5.8.1, the electronic registration form shall be accessed directly by the electronic address. Accessing the electronic address (in form of a website (printed URL) that contains the electronic registration form shall not cause additional screens or electronic banners to appear. In addition to the electronic address in form of a website,

manufacturers may include a code (such as a QR code or similar) to access the electronic address.

S5.9 * * *

(a) Each add-on child restraint system other than a car bed, harness and belt-positioning seat, shall have components permanently attached to the system that enable the restraint to be securely fastened to the lower anchorages of the child restraint anchorage system specified in Standard No. 225 (§ 571.225) and depicted in Drawing Package SAS-100-1000, Standard Seat Belt Assembly with Addendum A or in Drawing Package, “NHTSA Standard Seat Assembly; FMVSS No. 213, No. NHTSA-213-2003” (both incorporated by reference, see § 571.5). The components must be attached by use of a tool, such as a screwdriver. In the case of rear-facing child restraints with detachable bases, only the base is required to have the components.

* * * * *

S6.1.1 * * *

(a) * * *

(2) * * *

(i) * * *

(B) The platform is instrumented with an accelerometer and data processing system having a frequency response of 60 Hz channel frequency class as specified in SAE Recommended Practice J211/1, (incorporated by reference, see § 571.5). The accelerometer sensitive axis is parallel to the direction of test platform travel.

* * * * *

(ii) * * *

(G) All instrumentation and data reduction are in conformance with SAE Recommended Practice J211/1 (1995), “Instrumentation for Impact Tests,” (incorporated by reference, see § 571.5).

* * * * *

S6.1.2 * * *

(a) * * *

(1) * * *

(i) * * *

(B) Except for a child harness, a school bus child restraint system, and a restraint designed for use by children with physical disabilities, install the child restraint system at the center seating position of the standard seat assembly as in S6.1.2(a)(1)(i)(A), except that no tether strap (or any other supplemental device) is used.

* * * * *

S10.2.3 Hybrid III 6-year-old in belt-positioning seats, Hybrid III weighted 6-year-old in belt-positioning seats, and Hybrid III 10-year-old in belt-positioning seats. When using the Hybrid III 6-year-old (part 572, subpart N), the Hybrid III weighted 6-year-old (part 572, subpart S), or the Hybrid III 10-year-old (part 572, subpart T) in belt-positioning seats, position the dummy in accordance with S5.6.1 or S5.6.2, while conforming to the following:

* * * * *

**Figure 9a-2 – Registration form for child restraint systems – product identification number and purchaser information side.
Applies to child restraint systems manufactured on or after December 5, 2024.**

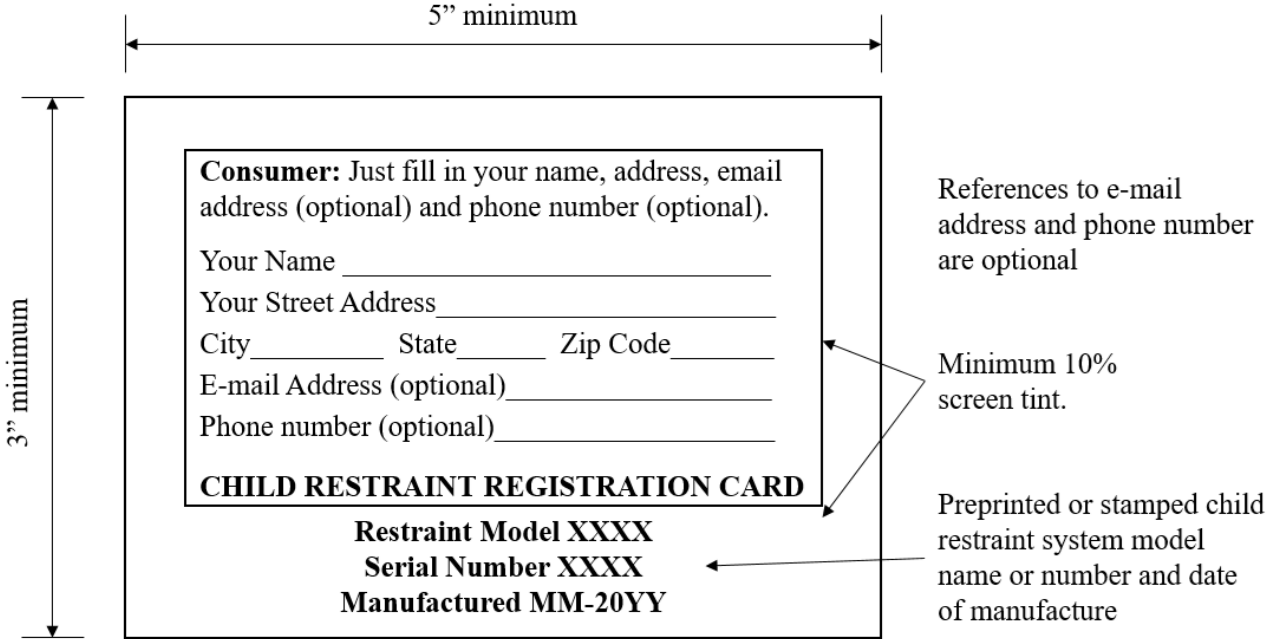

* * * * *

**Figure 9b-2 – Registration form for child restraint systems – address side.
Applies to child restraint systems manufactured on or after December 5, 2024.**

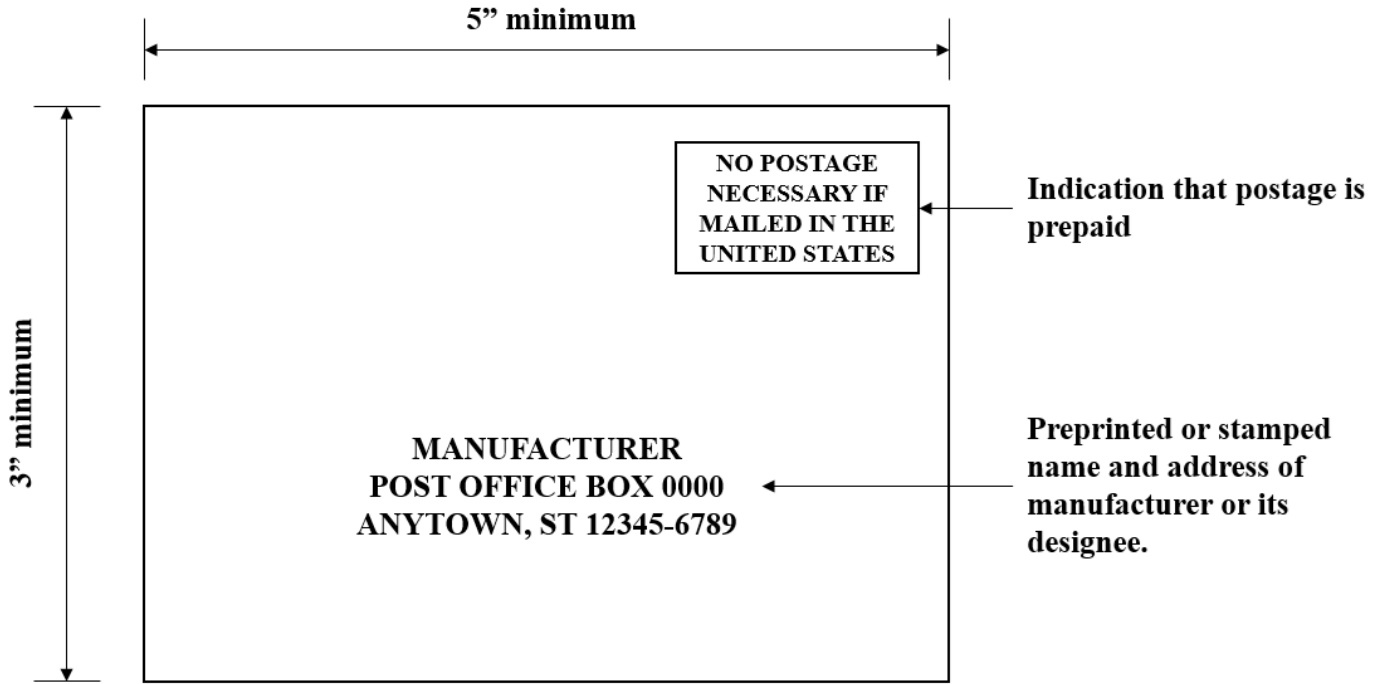

* * * * *

4. Section 571.213b is added to read as follows:

§ 571.213b Standard No. 213b; Child restraint systems; Mandatory applicability beginning
December 5, 2026.

S1. *Scope.* This standard specifies requirements for child restraint systems used in motor vehicles and aircraft.

S2. *Purpose.* The purpose of this standard is to reduce the number of children killed or injured in motor vehicle crashes and in aircraft.

S3. *Application.* This standard applies to passenger cars, multipurpose passenger vehicles, trucks and buses, and to child restraint systems for use in motor vehicles and aircraft, manufactured on or after December 5, 2026.

S4. *Definitions—*

Add-on child restraint system means any portable child restraint system.

Backless child restraint system means a child restraint system, other than a belt-positioning seat, that consists of a seating platform that does not extend up to provide a cushion for the child's back or head and has a structural element designed to restrain forward motion of the child's torso in a forward impact.

Belt-positioning seat means a child restraint system that positions a child on a vehicle seat to improve the fit of a vehicle Type 2 belt system on the child and that lacks any component, such as a belt system or a structural element, designed to restrain forward movement of the child's torso in a forward impact.

Booster seat means either a backless child restraint system or a belt-positioning seat.

Built-in child restraint system means a child restraint system that is designed to be an integral part of and permanently installed in a motor vehicle.

Car bed means a child restraint system designed to restrain or position a child in the supine or prone position on a continuous flat surface.

Child restraint anchorage system is defined in S3 of FMVSS No. 225 (§ 571.225).

Child restraint system means any device, except Type 1 or Type 2 seat belts, designed for use in a motor vehicle or aircraft to restrain, seat, or position children who weigh 36 kilograms (kg) (80 lb) or less.

Contactable surface means any child restraint system surface (other than that of a belt, belt buckle, or belt adjustment hardware) that may contact any part of the head or torso of the appropriate test dummy, specified in S7, when a child restraint system is tested in accordance with S6.1.

Factory-installed built-in child restraint system means a built-in child restraint system that has been or will be permanently installed in a motor vehicle before that vehicle is certified as a completed or altered vehicle in accordance with part 567 of this chapter.

Harness means a combination pelvic and upper torso child restraint system that consists primarily of flexible material, such as straps, webbing or similar material, and that does not include a rigid seating structure for the child.

Rear-facing child restraint system means a child restraint system, except a car bed, that positions a child to face in the direction opposite to the normal direction of travel of the motor vehicle.

Representative aircraft passenger seat means either a Federal Aviation Administration approved production aircraft passenger seat or a simulated aircraft passenger seat conforming to Figure 6.

School bus child restraint system means an add-on child restraint system (including a harness) manufactured and sold only for use on school bus seats, that has a label conforming with S5.3.1(b).

Seat orientation reference line or *SORL* means the horizontal line through Point Z as illustrated in Figure 1A-1 and 1A-2.

Specific vehicle shell means the actual vehicle model part into which the built-in child restraint system is or is intended to be fabricated, including the complete surroundings of the

built-in system. If the built-in child restraint system is or is intended to be fabricated as part of any seat other than a front seat, these surroundings include the back of the seat in front, the interior rear side door panels and trim, the floor pan, adjacent pillars (e.g., the B and C pillars), and the ceiling. If the built-in system is or is intended to be fabricated as part of the front seat, these surroundings include the dashboard, the steering mechanism and its associated trim hardware, any levers and knobs installed on the floor or on a console, the interior front side door panels and trim, the front seat, the floor pan, the A pillars and the ceiling.

Tether anchorage is defined in S3 of FMVSS No. 225 (§ 571.225).

Tether hook is defined in S3 of FMVSS No. 225 (§ 571.225).

Tether strap is defined in S3 of FMVSS No. 225 (§ 571.225).

Torso means the portion of the body of a seated anthropomorphic test dummy, excluding the thighs, that lies between the top of the child restraint system seating surface and the top of the shoulders of the test dummy.

S5. *Requirements.* (a) Each motor vehicle with a built-in child restraint system shall meet the requirements in this section when, as specified, tested in accordance with S6.1 and this paragraph.

(b)(1) Each child restraint system manufactured for use in motor vehicles shall meet the requirements in this section when, as specified, tested in accordance with S6.1 and this paragraph. Each add-on system shall meet the requirements at each of the restraint's seat back angle adjustment positions and restraint belt routing positions, when the restraint is oriented in the direction recommended by the manufacturer (e.g., forward, rearward or laterally) pursuant to S5.6, and tested with the test dummy specified in S7.

(2) Each add-on child restraint system manufactured for use in motor vehicles, that is recommended for children in a weight range that includes weights up to 18 kilograms (40 pounds) regardless of height, or for children in a height range that includes heights up to 1100

millimeters (mm) regardless of weight, shall meet the requirements in this standard and the applicable side impact protection requirements in Standard No. 213a (§ 571.213a).

(c) Each child restraint system manufactured for use in aircraft shall meet the requirements in this section and the additional requirements in S8.

(d) Each child restraint system tested with a part 572 subpart S dummy need not meet S5.1.2 and S5.1.3.

(e) Each child restraint system tested with a part 572 subpart T dummy need not meet S5.1.2.1(a).

(f) Each child restraint system that is equipped with an internal harness or other internal components to restrain the child need not meet this standard when attached to the lower anchors of the child restraint anchorage system on the standard seat assembly if the sum of the weight of the child restraint system (in pounds) and the average weight of child represented by the test dummy used to test the child restraint system in accordance with S7 of this standard, shown in the table below, exceeds 65 pounds. Such a child restraint system must meet this standard when tested using its internal harness or components to restrain such a test dummy while installed using the means of installation specified in S5.3.2 of this standard.

Table 1 to S5(f) - Average Weight of Child Represented by Various Test Dummies

| Test dummy (specified in S7 of this standard) | Average weight of child represented by test dummy (pounds) |
|---|---|
| CRABI 12-month-old infant dummy (49 CFR Part 572, Subpart R) | 22 |
| Hybrid III 3-year-old dummy (49 CFR Part 572, Subpart P) | 31 |
| Hybrid III 6-year-old dummy (49 CFR Part 572, Subpart N) | 45 |
| Hybrid III 6-year-old weighted dummy (49 CFR Part 572 Subpart S) | 62 |
| Hybrid II 6-year-old dummy (49, CFR Part 572, Subpart I) | 45 |

(g) Each add-on child restraint system manufactured for use in motor vehicles, that is recommended for children in a weight range that includes weights less than 18 kilograms (40 pounds) regardless of height, or for children in a height range that includes heights less than 1100 millimeters regardless of weight, shall meet the requirements in this standard and the applicable side impact protection requirements in Standard No. 213a (§ 571.213a).

S5.1 Dynamic performance.

S5.1.1 Child restraint system integrity. When tested in accordance with S6.1, each child restraint system shall meet the requirements of paragraphs (a) through (c) of this section.

(a) Exhibit no complete separation of any load bearing structural element and no partial separation exposing either surfaces with a radius of less than 1/4 inch or surfaces with protrusions greater than 3/8 inch above the immediate adjacent surrounding contactable surface of any structural element of the system.

(b)(1) If adjustable to different positions, remain in the same adjustment position during the testing that it was in immediately before the testing, except as otherwise specified in paragraph (b)(2).

(2)(i) Subject to paragraph (b)(2)(ii) of this section, a rear-facing child restraint system may have a means for repositioning the seating surface of the system that allows the system's occupant to move from a reclined position to an upright position and back to a reclined position during testing.

(ii) No opening that is exposed and is larger than 1/4 inch before the testing shall become smaller during the testing as a result of the movement of the seating surface relative to the restraint system as a whole.

(c) If a front facing child restraint system, not allow the angle between the system's back support surfaces for the child and the system's seating surface to be less than 45 degrees at the completion of the test.

S5.1.2 Injury criteria.

S5.1.2.1 When tested in accordance with S6.1 and with the test dummies specified in S7, each child restraint system shall:

(a) Limit the resultant acceleration at the location of the accelerometer mounted in the test dummy head such that, for any two points in time, t_1 and t_2 , during the event which are separated by not more than a 36 millisecond time interval and where t_1 is less than t_2 , the maximum calculated head injury criterion (HIC36) shall not exceed 1,000, determined using the resultant head acceleration at the center of gravity of the dummy head, a , expressed as a multiple of g (the acceleration of gravity), calculated using the expression below. The HIC calculation shall be calculated within the first 175 milliseconds of the sled acceleration that is within the acceleration corridor in Figure 2, when testing with the HIII-6YO dummy in a backless child restraint system.

Equation 1 to S5.1.2.1(a)

$$\text{HIC} = \left[\frac{1}{(t_2 - t_1)} \int_{t_1}^{t_2} a dt \right]^{2.5} (t_2 - t_1)$$

(b) The resultant acceleration calculated from the output of the thoracic instrumentation shall not exceed 60 g's, except for intervals whose cumulative duration is not more than 3 milliseconds.

S5.1.2.2 [Reserved.]

S5.1.3 *Occupant excursion.* When tested in accordance with S6.1 and the requirements specified in this section, each child restraint system shall meet the applicable excursion limit requirements specified in S5.1.3.1-S5.1.3.3.

S5.1.3.1 *Child restraint systems other than rear-facing ones and car beds.* Each child restraint system, other than a rear-facing child restraint system or a car bed, shall retain the test dummy's torso within the system.

(a) For each add-on child restraint system:

(1) No portion of the test dummy's head shall pass through a vertical transverse plane that is 720 mm or 813 mm (as specified in the table in this S5.1.3.1) forward of point Z on the standard seat assembly, measured along the center SORL (as illustrated in figure 1B-1 and 1B-2 of this standard); and

(2) Neither knee pivot point shall pass through a vertical transverse plane that is 915 mm forward of point Z on the standard seat assembly, measured along the center SORL.

Table 2 to S5.1.3.1(a)— Add-On Child Restraints that Can be Used Forward-Facing

| When this type of child restraint system | Is tested in accordance with— | These excursion limits apply | Explanatory note: in the test specified in 2nd column, the excursion requirement must be met when the child restraint system is attached to the test seat assembly in the manner described below, subject to certain conditions |
|---|--------------------------------------|-------------------------------------|--|
| Harnesses and restraints designed for use by children with physical disabilities | S6.1.2(a)(1)(i)(A) | Head 813 mm; Knee 915 mm. | Attached with lap and shoulder belt; in addition, if a tether is provided, it is attached. |
| School bus child restraint systems | S6.1.2(a)(1)(i)(A) | Head 813 mm; Knee 915 mm | Attached with seat back mount, or seat back and seat pan mounts. |
| Booster seats | S6.1.2(a)(1)(ii) | Head 813 mm; Knee 915 mm | Attached with lap and shoulder belt; no tether is attached. |
| Child restraint systems other than harnesses, restraints designed for use by children with physical disabilities, school bus child restraint systems, and booster seats | S6.1.2(a)(1)(i)(B) | Head 813 mm; Knee 915 mm | Attached with a lap belt; without a tether attached. Attached with a lap and shoulder belt; without a tether attached. Attached to lower anchorages of child restraint anchorage system; without a tether attached. |

| When this type of child restraint system | Is tested in accordance with— | These excursion limits apply | Explanatory note: in the test specified in 2nd column, the excursion requirement must be met when the child restraint system is attached to the test seat assembly in the manner described below, subject to certain conditions |
|--|--|------------------------------|--|
| Child restraint systems other than harnesses, restraints designed for use by children with physical disabilities, school bus child restraint systems | S6.1.2(a)(1)(i)(A), S6.1.2(a)(1)(i)(C) | Head 720 mm; Knee 915 mm | Attached with a lap belt, with a tether attached. Attached with a lap and shoulder belt, with a tether attached. Attached to lower anchorages of child restraint anchorage system, with a tether attached. |
| Child restraint systems equipped with a fixed or movable surface described in S5.2.2.2 that has belts that are not an integral part of that fixed or movable surface | S6.1.2(a)(2) | Head 813 mm; Knee 915 mm | Attached with lap belt or lap and shoulder belt or lower anchorages of child restraint anchorage system; no tether is attached. |

(b) In the case of a built-in child restraint system, neither knee pivot point shall, at any time during the dynamic test, pass through a vertical transverse plane that is 305 mm forward of the initial pre-test position of the respective knee pivot point, measured along a horizontal line that passes through the knee pivot point and is parallel to the vertical longitudinal plane that passes through the vehicle's longitudinal centerline.

S5.1.3.2 *Rear-facing child restraint systems.* In the case of each rear-facing child restraint system, all portions of the test dummy's torso shall be retained within the system and neither of the target points on either side of the dummy's head and on the transverse axis passing through the center of mass of the dummy's head and perpendicular to the head's midsagittal plane, shall

pass through the transverse orthogonal planes whose intersection contains the forward-most and top-most points on the child restraint system surfaces (illustrated in Figure 1C in this section).

S5.1.3.3 *Car beds.* In the case of car beds, all portions of the test dummy's head and torso shall be retained within the confines of the car bed.

S5.1.4 *Back support angle.* When a rear-facing child restraint system is tested in accordance with S6.1, the angle between the system's back support surface for the child and the vertical shall not exceed 70 degrees.

S5.2 *Force distribution.*

S5.2.1 *Minimum head support surface - child restraint systems other than car beds.*

S5.2.1.1 Except as provided in S5.2.1.2, each child restraint system other than a car bed shall provide restraint against rearward movement of the head of the child (rearward in relation to the child) by means of a continuous seat back which is an integral part of the system and which -

(a) Has a height, measured along the system seat back surface for the child in the vertical longitudinal plane passing through the longitudinal centerline of the child restraint systems from the lowest point on the system seating surface that is contacted by the buttocks of the seated dummy, as follows:

Table 3 to S5.2.1.1(a)

| Weight¹ | Height²(mm) |
|---------------------------|-------------------------------|
| Not more than 18 kg | 500 |
| More than 18 kg | 560 |

¹ When a child restraint system is recommended under S5.5 for use by children of the above weights.

² The height of the portion of the system seat back providing head restraint shall not be less than the above.

(b) Has a width of not less than 8 inches, measured in the horizontal plane at the height specified in paragraph (a) of this section. Except that a child restraint system with side supports extending at least 4 inches forward from the padded surface of the portion of the restraint system

provided for support of the child's head may have a width of not less than 6 inches, measured in the horizontal plane at the height specified in paragraph (a) of this section.

(c) Limits the rearward rotation of the test dummy head so that the angle between the head and torso of the dummy specified in S7 when tested in accordance with S6.1 is not more than 45 degrees greater than the angle between the head and torso after the dummy has been placed in the system in accordance with S6.1.2.3 and before the system is tested in accordance with S6.1.

S5.2.1.2 The applicability of the requirements of S5.2.1.1 to a front-facing child restraint system, and the conformance of any child restraint system other than a car bed to those requirements, is determined using the largest of the test dummies specified in S7 for use in testing that restraint, provided that the 6-year-old dummy described in subpart I or subpart N of part 572 of this title and the 10-year-old dummy described in subpart T of part 572 of this title, are not used to determine the applicability of or compliance with S5.2.1.1. A front facing child restraint system is not required to comply with S5.2.1.1 if the target point on either side of the dummy's head is below a horizontal plane tangent to the top of -

(a) The standard seat assembly, in the case of an add-on child restraint system, when the dummy is positioned in the system and the system is installed on the assembly in accordance with S6.1.2.

(b) The vehicle seat, in the case of a built-in child restraint system, when the system is activated and the dummy is positioned in the system in accordance with S6.1.2.

S5.2.2 *Torso impact protection.* Each child restraint system other than a car bed shall comply with the applicable requirements of S5.2.2.1 and S5.2.2.2.

S5.2.2.1 (a) The system surface provided for the support of the child's back shall be flat or concave and have a continuous surface area of not less than 85 square inches.

(b) Each system surface provided for support of the side of the child's torso shall be flat or concave and have a continuous surface of not less than 24 square inches for systems

recommended for children weighing 20 pounds or more, or 48 square inches for systems recommended for children weighing less than 20 pounds.

(c) Each horizontal cross section of each system surface designed to restrain forward movement of the child's torso shall be flat or concave and each vertical longitudinal cross section shall be flat or convex with a radius of curvature of the underlying structure of not less than 2 inches.

S5.2.2.2 Each forward-facing child restraint system shall have no fixed or movable surface -

(a) Directly forward of the dummy and intersected by a horizontal line -

(1) Parallel to the SORL, in the case of the add-on child restraint system, or

(2) Parallel to a vertical plane through the longitudinal center line of the vehicle seat, in the case of a built-in child restraint system, and,

(b) Passing through any portion of the dummy, except for surfaces which restrain the dummy when the system is tested in accordance with S6.1.2(a)(2), so that the child restraint system shall conform to the requirements of S5.1.2 and S5.1.3.1.

S5.2.3 [Reserved]

S5.2.4 *Protrusion limitation.* Any portion of a rigid structural component within or underlying a contactable surface, or any portion of a child restraint system surface that is subject to the requirements of S5.2.3 shall, with any padding or other flexible overlay material removed, have a height above any immediately adjacent restraint system surface of not more than 3/8 inch and no exposed edge with a radius of less than 1/4 inch.

S5.3 *Installation.*

S5.3.1 Add-on child restraint systems shall meet either (a) or (b), as appropriate.

(a) Except for components designed to attach to a child restraint anchorage system, each add-on child restraint system must not have any means designed for attaching the system to a

vehicle seat cushion or vehicle seat back and any component (except belts) that is designed to be inserted between the vehicle seat cushion and vehicle seat back.

(b) School bus child restraint systems (including harnesses manufactured for use on school bus seats) must have a label that conforms in content to Figure 12 and to the requirements of S5.3.1(b)(1) through S5.3.1(b)(3) of this standard. The label must be permanently affixed to the part of the school bus child restraint system, that attaches the system to a vehicle seat back.

(1) The label must be plainly visible when installed and easily readable.

(2) The message area must be white with black text. The message area must be no less than 20 square centimeters.

(3) The pictogram shall be gray and black with a red circle and slash on a white background. The pictogram shall be no less than 20 mm in diameter.

(c) The provision that add-on child restraint systems shall meet the requirements of this standard when installed solely by a Type 1 belt applies to child restraint systems manufactured before September 1, 2029. Except for harnesses, the requirement sunsets for child restraint systems manufactured on or after September 1, 2029. For harnesses, the requirement does not sunset and continues to apply to harnesses manufactured on or after September 1, 2029.

S5.3.2 Each add-on child restraint system shall be capable of meeting the requirements of this standard when installed solely by each of the means indicated in the following table for the particular type of child restraint system:

Table 4 for S5.3.2 Means of Installation for Child Restraint Systems

| Type of add-on child restraint system | Type 1 seat belt assembly plus a tether anchorage, if needed | Type 1 seat belt assembly | Type 2 seat belt assembly plus a tether anchorage, if needed | Type 2 seat belt assembly | Lower anchorages of the child restraint anchorage system plus a tether, if needed | Lower anchorages of the child restraint anchorage system | Seat back mount, or, seat back mount, and, seat pan mount |
|--|---|----------------------------------|---|----------------------------------|--|---|--|
| School bus child | | | | | | | X |

| | | | | | | | |
|-----------------------------------|---|---|---|---|---|---|--|
| restraint systems | | | | | | | |
| Harnesses | X | | | | | | |
| Car beds | | X | | X | | | |
| Rear-facing restraints | | X | | X | | X | |
| Booster seats | | | | X | | | |
| All other child restraint systems | X | X | X | X | X | X | |

S5.3.3 *Car beds*. Each car bed shall be designed to be installed on a vehicle seat so that the car bed's longitudinal axis is perpendicular to a vertical longitudinal plane through the longitudinal axis of the vehicle.

S5.4 *Belts, belt buckles, and belt webbing*.

S5.4.1 *Performance requirements*.

S5.4.1.1 [Reserved.]

S5.4.1.2 The webbing of belts provided with a child restraint system and used to attach the system to the vehicle or to restrain the child within the system shall -

(a) Have a minimum breaking strength for new webbing of not less than 15,000 N in the case of webbing used to secure a child restraint system to the vehicle, including the tether and lower anchorages of a child restraint anchorage system, and not less than 11,000 N in the case of the webbing used to secure a child to a child restraint system when tested in accordance with S5.1 of FMVSS No. 209. Each value shall be not less than the 15,000 N and 11,000 N applicable breaking strength requirements, but the median value shall be used for determining the retention of breaking strength in paragraphs (b)(1) and (c)(1) and (2) of this section. "New webbing" means webbing that has not been exposed to abrasion, light or micro-organisms as specified elsewhere in this section.

(b)(1) After being subjected to abrasion as specified in S5.1(d) or S5.3(c) of FMVSS 209 (§ 571.209), have a breaking strength of not less than 75 percent of the new webbing strength, when tested in accordance with S5.1(b) of FMVSS 209.

(2) A mass of 2.35 ± 0.05 kg shall be used in the test procedure in S5.1(d) of FMVSS 209 for webbing, including webbing to secure a child restraint system to the tether and lower anchorages of a child restraint anchorage system, except that a mass of 1.5 ± 0.05 kg shall be used for webbing in pelvic and upper torso restraints of a belt assembly used in a child restraint system. The mass is shown as (B) in Figure 2 of FMVSS 209.

(c)(1) After exposure to the light of a carbon arc and tested by the procedure specified in S5.1(e) of FMVSS 209 (§ 571.209), have a breaking strength of not less than 60 percent of the new webbing, and shall have a color retention not less than No. 2 on the AATCC Gray Scale for Color Change (incorporated by reference, see § 571.5).

(2) After being subjected to micro-organisms and tested by the procedures specified in S5.1(f) of FMVSS 209 (§ 571.209), shall have a breaking strength not less than 85 percent of the new webbing.

(d) If contactable by the test dummy torso when the system is tested in accordance with S6.1, have a width of not less than $1\frac{1}{2}$ inches when measured in accordance with S5.4.1.3.

S5.4.1.3 Width test procedure. Condition the webbing for 24 hours in an atmosphere of any relative humidity between 48 and 67 percent, and any ambient temperature between 70° and 77 °F. Measure belt webbing width under a tension of 5 pounds applied lengthwise.

S5.4.2 Belt buckles and belt adjustment hardware. Each belt buckle and item of belt adjustment hardware used in a child restraint system shall conform to the requirements of S4.3(a) and S4.3(b) of FMVSS No. 209 (§ 571.209).

S5.4.3 Belt Restraint.

S5.4.3.1 General. Each belt that is part of a child restraint system and that is designed to restrain a child using the system shall be adjustable to snugly fit any child whose height and

weight are within the ranges recommended in accordance with S5.5.2(f) and who is positioned in the system in accordance with the instructions required by S5.6.

S5.4.3.2 *Direct restraint.* Except for belt-positioning seats, each belt that is part of a child restraint system and that is designed to restrain a child using the system and to attach the system to the vehicle, and each Type 1 and lap portion of a Type 2 vehicle belt that is used to attach the system to the vehicle shall, when tested in accordance with S6.1, impose no loads on the child that result from the mass of the system, or -

(a) In the case of an add-on child restraint system, from the mass of the seat back of the standard seat assembly specified in S6.1, or

(b) In the case of a built-in child restraint system, from the mass of any part of the vehicle into which the child restraint system is built.

S5.4.3.3 *Seating systems.* Except for child restraint systems subject to S5.4.3.4, each child restraint system that is designed for use by a child in a seated position and that has belts designed to restrain the child, shall, with the test dummy specified in S7 positioned in the system in accordance with S10 provide:

(a) Upper torso restraint in the form of:

(i) Belts passing over each shoulder of the child, or

(ii) A fixed or movable surface that complies with S5.2.2.1(c), and

(b) Lower torso restraint in the form of:

(i) A lap belt assembly making an angle between 45° and 90° with the child restraint system seating surface at the lap belt attachment points, or

(ii) A fixed or movable surface that complies with S5.2.2.1(c), and

(c) In the case of each seating system recommended for children whose masses are more than 10 kg, crotch restraint in the form of:

(i) A crotch belt connectable to the lap belt or other device used to restrain the lower torso, or

(ii) A fixed or movable surface that complies with S5.2.2.1(c).

S5.4.3.4 *Harnesses*. Each child harness shall:

(a) Provide upper torso restraint, including belts passing over each shoulder of the child;

(b) Provide lower torso restraint by means of lap and crotch belt; and

(c) Prevent a child of any height for which the restraint is recommended for use pursuant to S5.5.2(f) from standing upright on the vehicle seat when the child is placed in the device in accordance with the instructions required by S5.6.

S5.4.3.5 *Buckle release*. Any buckle in a child restraint system belt assembly designed to restrain a child using the system shall:

(a) When tested in accordance with S6.2.1 prior to the dynamic test of S6.1, not release when a force of less than 40 newtons (N) is applied and shall release when a force of not more than 62 N is applied;

(b) After the dynamic test of S6.1, when tested in accordance with the appropriate sections of S6.2, release when a force of not more than 71 N is applied, provided, however, that the conformance of any child restraint system to this requirement is determined using the largest of the test dummies specified in S7 for use in testing that restraint when the restraint is facing forward, rearward, and/or laterally;

(c) Meet the requirements of S4.3(d)(2) of FMVSS No. 209 (§ 571.209), except that the minimum surface area for child restraint system buckles designed for push button application shall be 0.6 square inch;

(d) Meet the requirements of S4.3(g) of FMVSS No. 209 (§ 571.209) when tested in accordance with S5.2(g) of FMVSS No. 209; and

(e) Not release during the testing specified in S6.1.

S5.5 *Labeling*. Any labels or written instructions provided in addition to those required by this section shall not obscure or confuse the meaning of the required information or be

otherwise misleading to the consumer. Any labels or written instructions other than in the English language shall be an accurate translation of English labels or written instructions.

S5.5.1 Each add-on child restraint system shall be permanently labeled with the information specified in S5.5.2(a) through (m).

S5.5.2 The information specified in paragraphs (a) through (m) of this section shall be stated in the English language and lettered in letters and numbers that are not smaller than 10 point type. Unless otherwise specified, the information shall be labeled on a white background with black text. Unless written in all capitals, the information shall be stated in sentence capitalization.

(a) The model name or number of the system.

(b) The manufacturer's name. A distributor's name may be used instead if the distributor assumes responsibility for all duties and liabilities imposed on the manufacturer with respect to the system by the National Traffic and Motor Vehicle Safety Act, as amended.

(c) The statement: "Manufactured in _____," inserting the month and year of manufacture.

(d) The place of manufacture (city and State, or foreign country). However, if the manufacturer uses the name of the distributor, then it shall state the location (city and State, or foreign country) of the principal offices of the distributor.

(e) The statement: "This child restraint system conforms to all applicable Federal motor vehicle safety standards."

(f) Statements or a combination of statements and pictograms specifying the manufacturer's recommendations for the weight and height ranges (in English and metric units) of children who can safely occupy the system in each applicable mode (rear-facing, forward-facing, booster), except manufacturers shall not recommend that child restraint systems with internal harnesses be used forward-facing with children of weights less than 12 kg (26.5 lb), and shall not recommend that booster seats be used by children of weights less than 18.4 kg (40 lb).

(g) The statements specified in paragraphs (1) and (2):

(1) A heading as specified in S5.5.2(k)(3)(i), with the statement “WARNING! DEATH or SERIOUS INJURY can occur,” capitalized as written and followed by bulleted statements in the following order:

(i) As appropriate, the statements required by the following sections will be bulleted and placed after the statement required by 5.5.2(g)(1) in the following order: 5.5.2(k)(1), 5.5.2(h), 5.5.2(j), and 5.5.2(i).

(ii) Secure this child restraint with the vehicle's child restraint anchorage system, if available, or with a vehicle belt. [For car beds, harnesses, and belt-positioning seats, the first part of the statement regarding attachment by the child restraint anchorage system is optional.] [For belt-positioning seats, the second part of the statement regarding attachment by the vehicle belt does not apply.] Child restraint systems equipped with internal harnesses to restrain the child and with components to attach to a child restraint anchorage system and for which the combined weight of the child restraint system and the maximum recommended child weight for use with internal harnesses exceeds 65 pounds, must be labeled with the following statement: “Do not use the lower anchors of the child restraint anchorage system (LATCH system) to attach this child restraint when restraining a child weighing more than * [**insert a recommended weight value in English and metric units such that the sum of the recommended weight value and the weight of the child restraint system does not exceed 65 pounds (29.5 kg)*] with the internal harnesses of the child restraint.”

(iii) Follow all instructions on this child restraint and in the written instructions located (*insert storage location on the restraint for the manufacturer's installation instruction booklet or sheet*).

(iv) Register your child restraint with the manufacturer.

(2) At the manufacturer's option, the phrase “DEATH or SERIOUS INJURY can occur” in the heading can be on either a white or yellow background.

(3) More than one label may be used for the required bulleted statements. Multiple labels shall be placed one above the other unless that arrangement is precluded by insufficient space or shape of the child restraint system. In that case, multiple labels shall be placed side by side. When using multiple labels, the mandated warnings must be in the correct order when read from top to bottom. If the labels are side-by-side, then the mandated warnings must appear top to bottom of the leftmost label, then top to bottom of the next label to its right, and so on. There shall be no intervening labels and the required heading shall only appear on the first label in the sequence.

(h) In the case of each child restraint system that has belts designed to restrain children using them and which do not adjust automatically to fit the child: Snugly adjust the belts provided with this child restraint around your child.

(i)(1) For a booster seat that is recommended for use with either a vehicle's Type 1 or Type 2 seat belt assembly, one of the following statements, as appropriate:

(i) Use only the vehicle's lap and shoulder belt system when restraining the child in this booster seat; or,

(ii) Use only the vehicle's lap belt system, or the lap belt part of a lap/shoulder belt system with the shoulder belt placed behind the child, when restraining the child in this seat.

(2)(i) Except as provided in paragraph (i)(2)(ii) of this section, for a booster seat which is recommended for use with both a vehicle's Type 1 and Type 2 seat belt assemblies, the following statement: Use only the vehicle's lap belt system, or the lap belt part of a lap/shoulder belt system with the shoulder belt placed behind the child, when restraining the child with the *(insert description of the system element provided to restrain forward movement of the child's torso when used with a lap belt (e.g., shield))*, and only the vehicle's lap and shoulder belt system when using the booster without the *(insert above description)*.

(ii) A booster seat which is recommended for use with both a vehicle's Type 1 and Type 2 seat belt assemblies is not subject to S5.5.2(i)(2)(i) if, when the booster is used with the shield or

similar component, the booster will cause the shoulder belt to be located in a position other than in front of the child when the booster is installed. However, such a booster shall be labeled with a warning to use the booster with the vehicle's lap and shoulder belt system when using the booster without a shield.

(j) In the case of each child restraint system equipped with a top anchorage strap, the statement: Secure the top anchorage strap provided with this child restraint.

(k)(1) In the case of each rear-facing child restraint system that is designed for infants only, the statement: Use only in a rear-facing position when using it in the vehicle.

(2) [Reserved]

(3) Except as provided in (k)(4) of this section, each child restraint system that can be used in a rear-facing position shall have a label that conforms in content to Figure 10 and to the requirements of S5.5.2(k)(3)(i) through S5.5.2(k)(3)(iii) of this standard permanently affixed to the outer surface of the cushion or padding in or adjacent to the area where a child's head would rest, so that the label is plainly visible and easily readable.

(i) The heading area shall be yellow with the word “warning” and the alert symbol in black.

(ii) The message area shall be white with black text. The message area shall be no less than 30 square cm.

(iii) The pictogram shall be black with a red circle and slash on a white background. The pictogram shall be no less than 30 mm in diameter.

(4) If a child restraint system is equipped with a device that deactivates the passenger-side air bag in a vehicle when and only when the child restraint is installed in the vehicle and provides a signal, for at least 60 seconds after deactivation, that the air bag is deactivated, the label specified in Figure 10 may include the phrase “unless air bag is off” after “on front seat with air bag.”

(1) An installation diagram showing the child restraint system installed in:

(1) A seating position equipped with a continuous-loop lap/shoulder belt;

(2) For child restraint systems manufactured before September 1, 2029, a seating position equipped with only a lap belt, as specified in the manufacturer's instructions; and

(3) A seating position equipped with a child restraint anchorage system. For child restraint systems the following paragraphs (1)(3)(i) and (ii) of this section apply, as appropriate.

(i) If the child restraint system is designed to meet the requirements of this standard when installed by the child restraint anchorage system according to S5.3.2, and if the sum of the weight of the child restraint system and the maximum child weight recommended for the child restraint system when used with the restraint's internal harness or components is greater than 65 lb when used forward-facing or rear-facing, include the following statement on this installation diagram: "Do not install by this method for a child weighing more than *." At the manufacturer's option, "*" is the child weight limit in English units in accordance with S5.5.2(1)(3)(i)(A), (B), or (C). The corresponding child weight limit in metric units may also be included in the statement at the manufacturer's option.

(A) For forward-facing and rear-facing child restraint systems, * is less than or equal to 65 minus child restraint system weight (pounds).

(B) For forward-facing child restraint systems, * is the child weight limit specified in the following table corresponding to the value CW, calculated as 65 minus child restraint system weight (pounds).

Table 5 to S5.5.2(1)(3)(i)(B) - Maximum Child Weight Limit for Lower Anchor Use for Forward-Facing Child Restraint System - Rounding

| <u>CW = 65 - child restraint system weight (pounds)</u> | <u>Child weight limit "*" (pounds)</u> |
|--|---|
| <u>$20 < CW \leq 25$</u> | <u>25</u> |
| <u>$25 < CW \leq 30$</u> | <u>30</u> |
| <u>$30 < CW \leq 35$</u> | <u>35</u> |
| <u>$35 < CW \leq 40$</u> | <u>40</u> |
| <u>$40 < CW \leq 45$</u> | <u>45</u> |
| <u>$45 < CW \leq 50$</u> | <u>50</u> |

| | |
|-------------------|-----------|
| $50 < CW \leq 55$ | <u>55</u> |
| $55 < CW \leq 60$ | <u>60</u> |

(C) For rear-facing child restraint systems, * is the child weight limit specified in the following table corresponding to the value CW, calculated as 60 minus child restraint system weight (pounds).

Table 6 to S5.5.2(l)(3)(i)(C) - Maximum Child Weight Limit for Lower Anchor Use for Rear-Facing Child Restraint System - Rounding

| <u>CW = 60 - child restraint system weight (pounds)</u> | <u>Child weight limit “*” (pounds)</u> |
|---|--|
| $15 < CW \leq 20$ | <u>20</u> |
| $20 < CW \leq 25$ | <u>25</u> |
| $25 < CW \leq 30$ | <u>30</u> |
| $30 < CW \leq 35$ | <u>35</u> |
| $35 < CW \leq 40$ | <u>40</u> |
| $40 < CW \leq 45$ | <u>45</u> |
| $45 < CW \leq 50$ | <u>50</u> |
| $50 < CW \leq 55$ | <u>55</u> |

(ii) For child restraint systems designed to meet the requirements of this standard when installed forward-facing and rear-facing using the child restraint anchorage system according to S5.3.2, the following applies:

(A) If separate installation diagrams are provided for the child restraint system installed forward-facing and rear-facing, S5.5.2(l)(3)(i) applies to each of the installation diagrams.

(B) If only one installation diagram is provided and if a statement specifying a child weight limit is required in only rear-facing or forward-facing mode pursuant to S5.5.2(l)(3)(i), then the diagram shall depict installation in that mode along with the corresponding child weight limit in accordance with S5.5.2(l)(3)(i).

(C) If a statement specifying a child weight limit is required for the child restraint system installed forward-facing and rear-facing pursuant to S5.5.2(l)(3)(i) and only one installation

diagram is provided, then the child weight limit shall be in accordance with S5.5.2(l)(3)(i)(A) or the lesser of the child weight limits described in S5.5.2(l)(3)(i)(B) and (C).

(m) Statements informing the owner of the importance of registering the child restraint system for recall purposes and instructing the owner how to register the child restraint system at least by both mail and telephone, providing a U.S. telephone number. The following statement must also be provided: “For recall information, call the U.S. Government's Vehicle Safety Hotline at 1-888-327-4236 (TTY: 1-800-424-9153), or go to *www.NHTSA.gov*.”

(n) Child restraint systems, other than belt-positioning seats, harnesses and backless child restraint systems, may be certified as complying with the provisions of S8. Child restraint systems that are so certified shall be labeled with the statement “This Restraint is Certified for Use in Motor Vehicles and Aircraft.” Belt-positioning seats, harnesses and backless child restraint systems shall be labeled with the statement “This Restraint is Not Certified for Use in Aircraft.” The statement required by this paragraph shall be in red lettering and shall be placed after the certification statement required by S5.5.2(e).

S5.5.3 The information specified in S5.5.2(f) through (l) shall be located on the add-on child restraint system so that it is visible when the system is installed as specified in S5.6.1, except that for child restraint systems with a detachable base, the installation diagrams specified in S5.5.2(l) are required to be visible only when the base alone is installed.

S5.5.4 (a) Each built-in child restraint system other than a factory-installed built-in restraint shall be permanently labeled with the information specified in S5.5.5 (a) through (l). The information specified in S5.5.5(a) through (j) and in S5.5.5(l) shall be visible when the system is activated for use.

(b) Each factory-installed built-in child restraint system shall be permanently labeled with the information specified in S5.5.5(f) through (j) and S5.5.5(l), so that the information is visible when the restraint is activated for use. The information shall also be included in the vehicle owner's manual.

S5.5.5 The information specified in paragraphs (a) through (l) of this section that is required by S5.5.4 for the built-in child restraint systems shall be in English and lettered in letters and numbers using a not smaller than 10-point type. Unless specified otherwise, the information shall be labeled on a white background with black text. Unless written in all capitals, the information shall be stated in sentence capitalization.

(a) The model name or number of the system.

(b) The manufacturer's name. A distributor's or dealer's name may be used instead if the distributor or dealer assumes responsibility for all duties and liabilities imposed on the manufacturer with respect to the system by the National Traffic and Motor Vehicle Safety Act, as amended.

(c) The statement: "Manufactured in _____," inserting the month and year of manufacture.

(d) The place of manufacture (city and State, or foreign country). However, if the manufacturer uses the name of the distributor or dealer, then it shall state the location (city and State, or foreign country) of the principal offices of the distributor or dealer.

(e) The statement: "This child restraint system conforms to all applicable Federal motor vehicle safety standards."

(f) Statements or a combination of statements and pictograms specifying the manufacturer's recommendations for the weight and height ranges (in English and metric units) of children who can safely occupy the system in each applicable mode (rear-facing, forward-facing, booster), except manufacturers shall not recommend forward-facing child restraint systems with internal harnesses for children of weights less than 12 kg (26.5 lb), and shall not recommend booster seats for children of weights less than 18.4 kg (40 lb).

(g) The heading and statement specified in paragraph (1), and if appropriate, the statements in paragraph (2) and (3). If used, the statements in paragraphs (2) and (3) shall be bulleted and precede the bulleted statement required by paragraph (1) after the heading.

(1) A heading as specified in S5.5.2(k)(3)(i), with the statement “WARNING! DEATH or SERIOUS INJURY can occur,” capitalized as written and followed by the bulleted statement: Follow all instructions on the child restraint and in the vehicle's owner's manual. At the manufacturer's option, the phrase “DEATH or SERIOUS INJURY can occur” in the heading can be on either a white or yellow background.

(2) In the case of each built-in child restraint system which is not intended for use in motor vehicles in certain adjustment positions or under certain circumstances, an appropriate statement of the manufacturers restrictions regarding those positions or circumstances.

(3) As appropriate, the statements required by the following sections will be bulleted and placed after the statement required by 5.5.5(g)(1) in the following order: 5.5.5(g)(2), 5.5.5(f), S5.5.5(h) and S5.5.5(i).

(h) In the case of each built-in child restraint system that has belts designed to restrain children using them and which do not adjust automatically to fit the child: Snugly adjust the belts provided with this child restraint around your child.

(i) In the case of each built-in child restraint which can be used in a rear-facing position, the following statement: Place an infant in a rear-facing position in this child restraint.

(j) A diagram or diagrams showing the fully activated child restraint system in infant and/or child configurations.

(k) One of the following statements, inserting an address and a U.S. telephone number. If a manufacturer opts to provide a Web site on the registration card as permitted in Figure 9a of this section, the manufacturer must include the statement in paragraph (k)(2) of this section:

(1) “Child restraints could be recalled for safety reasons. You must register this restraint to be reached in a recall. Send your name, address, e-mail address if available (preceding four words are optional), and the restraint's model number and manufacturing date to (*insert address*) or call (*insert a U.S. telephone number*). For recall information, call the U.S. Government's

Vehicle Safety Hotline at 1-888-327-4236 (TTY: 1-800-424-9153), or go to

http://www.NHTSA.gov.”

(2) “Child restraints could be recalled for safety reasons. You must register this restraint to be reached in a recall. Send your name, address, e-mail address if available (preceding four words are optional), and the restraint's model number and manufacturing date to (*insert address*) or call (*insert telephone number*) or register online at (*insert Web site for electronic registration form*). For recall information, call the U.S. Government's Vehicle Safety Hotline at 1-888-327-4236 (TTY: 1-800-424-9153), or go to *http://www.NHTSA.gov.*”

(1) In the case of a built-in belt-positioning seat that uses either the vehicle's Type 1 or Type 2 belt systems or both, a statement describing the manufacturer's recommendations for the maximum height and weight of children who can safely occupy the system and how the booster should be used (e.g., with or without shield) with the different vehicle belt systems.

S5.6 Printed instructions for proper use. Any labels or written instructions provided in addition to those required by this section shall not obscure or confuse the meaning of the required information or be otherwise misleading to the consumer. Any labels or written instructions other than in the English language shall be an accurate translation of English labels or written instructions. Unless written in all capitals, the information required by S5.6.1 through S5.6.3 shall be stated in sentence capitalization.

S5.6.1 Add-on child restraint systems. Each add-on child restraint system shall be accompanied by printed installation instructions in English that provide a step-by-step procedure, including diagrams, for installing the system in motor vehicles, securing the system in the vehicles, positioning a child in the system, and adjusting the system to fit the child. For each child restraint system that has components for attaching to a tether anchorage or a child restraint anchorage system, the installation instructions shall include a step-by-step procedure, including diagrams, for properly attaching to that anchorage or system.

S5.6.1.1 In a vehicle with rear designated seating positions, the instructions shall alert vehicle owners that, according to accident statistics, children are safer when properly restrained in the rear seating positions than in the front seating positions.

S5.6.1.2 The instructions shall specify in general terms the types of vehicles, the types of seating positions, and the types of vehicle seat belts with which the add-on child restraint system can or cannot be used.

S5.6.1.3 The instructions shall explain the primary consequences of not following the warnings required to be labeled on the child restraint system in accordance with S5.5.2(g) through (k).

S5.6.1.4 The instructions for each car bed shall explain that the car bed should be positioned in such a way that the child's head is near the center of the vehicle.

S5.6.1.5 The instructions shall state that add-on child restraint systems should be securely belted to the vehicle, even when they are not occupied, since in a crash an unsecured child restraint system may injure other occupants.

S5.6.1.6 Each add-on child restraint system shall have a location on the restraint for storing the manufacturer's instructions.

S5.6.1.7 Child restraint systems shall include statements informing the owner of the importance of registering the child restraint system for recall purposes and instructing the owner how to register the child restraint system at least by mail and by telephone, providing a U.S. telephone number. The following statement must also be provided: "For recall information, call the U.S. Government's Vehicle Safety Hotline at 1-888-327-4236 (TTY: 1-800-424-9153), or go to *www.NHTSA.gov*."

S5.6.1.8 In the case of each child restraint system that can be used in a position so that it is facing the rear of the vehicle, the instructions shall provide a warning against using restraints rear-facing at seating positions equipped with air bags, and shall explain the reasons for, and consequences of not following the warning. The instructions shall also include a statement that

owners of vehicles with front passenger-side air bags should refer to their vehicle owner's manual for child restraint system installation instructions.

S5.6.1.9 In the case of each rear-facing child restraint system that has a means for repositioning the seating surface of the system that allows the system's occupant to move from a reclined position to an upright position during dynamic testing, the instructions shall include a warning against impeding the ability of the restraint to change adjustment position.

S5.6.1.10 (a) For instructions for a booster seat that is recommended for use with either a vehicle's Type 1 or Type 2 seat belt assembly, one of the following statements, as appropriate, and the reasons for the statement:

(1) Warning! Use only the vehicle's lap and shoulder belt system when restraining the child in this booster seat; or,

(2) Warning! Use only the vehicle's lap belt system, or the lap belt part of a lap/shoulder belt system with the shoulder belt placed behind the child, when restraining the child in this seat.

(b)(1) Except as provided in S5.6.1.10(b)(2), the instructions for a booster seat that is recommended for use with both a vehicle's Type 1 and Type 2 seat belt assemblies shall include the following statement and the reasons therefor: Warning! Use only the vehicle's lap belt system, or the lap belt part of a lap/shoulder belt system with the shoulder belt placed behind the child, when restraining the child with the *(insert description of the system element provided to restrain forward movement of the child's torso when used with a lap belt (e.g., shield))*, and only the vehicle's lap and shoulder belt system when using this booster without the *(insert above description)*.

(2) A booster seat which is recommended for use with both a vehicle's Type 1 and Type 2 seat belt assemblies is not subject to S5.6.1.10(b)(1) if, when the booster is used with the shield or similar component, the booster will cause the shoulder belt to be located in a position other than in front of the child when the booster is installed. However, the instructions for such a

booster shall include a warning to use the booster with the vehicle's lap and shoulder belt system when using the booster without a shield.

(c) The instructions for belt-positioning seats shall include the statement, "This restraint is not certified for aircraft use," and the reasons for this statement.

S5.6.1.11 For school bus child restraint systems, the instructions must include the following statement:

"WARNING! This restraint must only be used on school bus seats. Entire seat directly behind must be unoccupied or have restrained occupants."

(The instruction's reference to a "restrained occupant" refers to an occupant restrained by any user-appropriate vehicle restraint or child restraint system (e.g., lap belt, lap and shoulder belt, booster seat or other child restraint system.)

S5.6.1.12 If the child restraint system is designed to meet the requirements of this standard when installed by the child restraint anchorage system according to S5.3.2, the installation diagram showing the child restraint system installed using a child restraint anchorage system must meet the specifications in S5.5.2(1)(3).

S5.6.2 *Built-in child restraint systems.* (a) Each built-in child restraint system shall be accompanied by printed instructions in English that provide a step-by-step procedure, including diagrams, for activating the restraint system, positioning a child in the system, adjusting the restraint and, if provided, the restraint harness to fit the child. The instructions for each built-in car bed shall explain that the child should be positioned in the bed in such a way that the child's head is near the center of the vehicle.

(b) Each motor vehicle equipped with a factory-installed built-in child restraint system shall have the information specified in paragraph (a) of this section included in its vehicle owner's manual.

S5.6.2.1 The instructions shall explain the primary consequences of not following the manufacturer's warnings for proper use of the child restraint system in accordance with S5.5.5(f) through (i).

S5.6.2.2 The instructions for each built-in child restraint system other than a factory-installed restraint shall include statements informing the owner of the importance of registering the child restraint system for recall purposes and instructing the owner how to register the child restraint system at least by mail and by telephone, providing a U.S. telephone number. The following statement must also be provided: "For recall information, call the U.S. Government's Vehicle Safety Hotline at 1-888-327-4236 (TTY: 1-800-424-9153), or go to *www.NHTSA.gov*."

S5.6.2.3. Each built-in child restraint system other than a factory-installed built-in restraint, shall have a location on the restraint for storing the instructions.

S5.6.2.4 Each built-in child restraint system, other than a system that has been installed in a vehicle or a factory-installed built-in system that is designed for a specific vehicle model and seating position, shall be accompanied by instructions in English that provide a step-by-step procedure for installing the system in a motor vehicle. The instructions shall specify the types of vehicles and the seating positions into which the restraint can or cannot be installed. The instructions for each car bed shall explain that the bed should be installed so that the child's head will be near the center of the vehicle.

S5.6.2.5 In the case of a built-in belt-positioning seat that uses either the vehicle's Type 1 or Type 2 belt systems or both, the instructions shall include a statement describing the manufacturer's recommendations for the maximum height and weight of children who can safely occupy the system and how the booster must be used with the vehicle belt systems appropriate for the booster seat. The instructions shall explain the consequences of not following the directions. The instructions shall specify that, if the booster seat is recommended for use with only the lap-belt part of a Type 2 assembly, the shoulder belt portion of the assembly must be placed behind the child.

S5.6.3 *Add-on and built-in child restraint systems.* In the case of each child restraint system that has belts designed to restrain children using them and which do not adjust automatically to fit the child, the printed instructions shall include the following statement: A snug strap should not allow any slack. It lies in a relatively straight line without sagging. It does not press on the child's flesh or push the child's body into an unnatural position.

S5.7 *Flammability.* Each material used in a child restraint system shall conform to the requirements of S4 of FMVSS No. 302 (571.302). In the case of a built-in child restraint system, the requirements of S4 of FMVSS No. 302 shall be met in both the “in-use” and “stowed” positions.

S5.8 Information requirements - attached registration form and electronic registration form.

S5.8.1 *Attached registration form.* (a) Each child restraint system, except a factory-installed built-in restraint system, shall have a registration form attached to any surface of the restraint that contacts the dummy when the dummy is positioned in the system in accordance with S6.1.2 of Standard 213. The form shall not have advertising or any information other than that related to registering the child restraint system.

(b) Each attached registration form shall provide a mail-in postcard that conforms in size, and in basic content and format to the forms depicted in Figures 9a' and 9b' of this section.

(1) The mail-in postcard shall:

(i) Have a thickness of at least 0.007 inches and not more than 0.0095 inches;

(ii) Be pre-printed with the information identifying the child restraint system for recall purposes, such as the model name or number and date of manufacture (month, year) of the child restraint system to which the form is attached;

(iii) Contain space for the owner to record his or her name, mailing address, e-mail address (optional), telephone number (optional) and other pertinent information;

(iv) Be addressed to the manufacturer, and be postage paid.

(v) Be detachable from the information card without the use of scissors or other tools.

(c) The registration form attached to the child restraint system shall also provide an information card with the following:

(1) Informing the owner of the importance of registering the child restraint system; and,

(2) Instructing the owner how to register the CRS.

(3) Manufacturers must provide statements informing the purchaser that the registration card is pre-addressed and that postage has been paid.

(4) Manufacturers may provide instructions to register the child restraint system electronically. If an electronic registration form is used or referenced, it must meet the requirements of S5.8.2 of this section.

(5) Manufacturers may optionally provide statements to the owner explaining that the registration card is not a warranty card, and that the information collected from the owner will not be used for marketing purposes.

S5.8.2 Electronic registration form. (a) Each electronic registration form must meet the requirements of this S5.8.2. Each form shall:

(1) Contain statements at the top of the form:

(i) Informing the owner of the importance of registering the CRS; and,

(ii) Instructing the owner how to register the CRS.

(2) Provide as required registration fields, space for the purchaser to record the model name or number and date of manufacture (month, year) of the child restraint system, and space for the purchaser to record his or her name and mailing address. At the manufacturer's option, a space is provided for the purchaser to optionally record his or her e-mail address. At the manufacturer's option, a space is provided for the purchaser to optionally record his or her telephone number.

(b) No advertising or other information shall appear on the electronic registration form.

However, manufacturers may optionally provide statements to the owner explaining that the

registration is not for a warranty, and that the information collected from the owner will not be used for marketing purposes.

(c) The electronic registration form may provide information identifying the manufacturer or a link to the manufacturer's home page, a field to confirm submission, and a prompt to indicate any incomplete or invalid fields prior to submission.

(d) If a manufacturer printed the electronic address (in form of a website (printed URL)) on the attached registration form provided pursuant to S5.8.1, the electronic registration form shall be accessed directly by the electronic address. Accessing the electronic address (in form of a website (printed URL)) that contains the electronic registration form shall not cause additional screens or electronic banners to appear. In addition to the electronic address in the form of a website, manufacturers may include a code (such as QR code or similar) to access the electronic address.

S5.9 Attachment to child restraint anchorage system. (a) Each add-on child restraint system other than a car bed, harness and belt-positioning seat, shall have components permanently attached to the system that enable the restraint to be securely fastened to the lower anchorages of the child restraint anchorage system specified in Standard No. 225 (§ 571.225) and depicted in NHTSA Standard Seat Assembly; FMVSS No. 213, No. NHTSA-213-2021, (March 2023) (incorporated by reference, see § 571.5). The components must be attached by use of a tool, such as a screwdriver. In the case of rear-facing child restraint systems with detachable bases, only the base is required to have the components.

(b) In the case of each child restraint system that has components for attaching the system to a tether anchorage, those components shall include a tether hook that conforms to the configuration and geometry specified in Figure 11 of this standard.

(c) In the case of each child restraint system that has components, including belt webbing, for attaching the system to a tether anchorage or to a child restraint anchorage system, the belt

webbing shall be adjustable so that the child restraint system can be tightly attached to the vehicle.

(d) Each child restraint system with components that enable the restraint to be securely fastened to the lower anchorages of a child restraint anchorage system, other than a system with hooks for attaching to the lower anchorages, shall provide either an indication when each attachment to the lower anchorages becomes fully latched or attached, or a visual indication that all attachments to the lower anchorages are fully latched or attached. Visual indications shall be detectable under normal daylight lighting conditions.

S6. Test conditions and procedures.

S6.1 Dynamic systems test for child restraint systems.

The test conditions described in S6.1.1 apply to the dynamic systems test. The test procedure for the dynamic systems test is specified in S6.1.2. The test dummy specified in S7 is placed in the test specimen (child restraint system), clothed as described in S9 and positioned according to S10.

S6.1.1 Test conditions—(a) Test devices. (1) Add-on child restraint systems. The test device for add-on child restraint systems is a standard seat assembly consisting of a simulated vehicle rear seat which is depicted in NHTSA Standard Seat Assembly; FMVSS No. 213, No. NHTSA-213-2021 (March 2023) (incorporated by reference; see § 571.5). The assembly is mounted on a dynamic test platform so that the center SORL of the seat is parallel to the direction of the test platform travel and so that movement between the base of the assembly and the platform is prevented. As illustrated in Figures 1A and 1B of this standard, attached to the seat belt anchorage points provided on the standard seat assembly is a Type 1 or a Type 2 seat belt assembly. The seat belt assembly meets the requirements of Standard No. 209 (§ 571.209) and has webbing with a width of not more than 2 inches, and are attached to the anchorage points without the use of retractors or reels of any kind. As illustrated in Figures 1A' and 1B' of this standard, attached to the standard seat assembly is a child restraint anchorage system conforming

to the specifications of Standard No. 225 (§ 571.225). The indentation force deflection (IFD) characteristics of the seat pan cushion and seat back cushion are described in drawing numbers 3021-233 and 3021-248 in the NHTSA Standard Seat Assembly; FMVSS No. 213, No. NHTSA-213-2021, (March 2023) (incorporated by reference; see § 571.5); the IFD is measured on the full size cushion samples using the test methodology and apparatus described in ASTM Standard D3574-11 (incorporated by reference; see § 571.5) at 50% indentation.

(2) The test device for built-in child restraint systems is either the specific vehicle shell or the specific vehicle.

(i) *Specific vehicle shell.* (A) The specific vehicle shell, if selected for testing, is mounted on a dynamic test platform so that the longitudinal center line of the shell is parallel to the direction of the test platform travel and so that movement between the base of the shell and the platform is prevented. Adjustable seats are in the adjustment position midway between the forwardmost and rearmost positions, and if separately adjustable in a vertical direction, are at the lowest position. If an adjustment position does not exist midway between the forwardmost and rearmost position, the closest adjustment position to the rear of the midpoint is used. Adjustable seat backs are in the manufacturer's nominal design riding position. If such a position is not specified, the seat back is positioned so that the longitudinal center line of the child test dummy's neck is vertical, and if an instrumented test dummy is used, the accelerometer surfaces in the dummy's head and thorax, as positioned in the vehicle, are horizontal. If the vehicle seat is equipped with adjustable head restraints, each is adjusted to its highest adjustment position.

(B) The platform is instrumented with an accelerometer and data processing system having a frequency response of 60 Hz channel frequency class as specified in SAE Recommended Practice J211/1, (incorporated by reference, see § 571.5). The accelerometer sensitive axis is parallel to the direction of test platform travel.

(ii) *Specific vehicle.* For built-in child restraint systems, an alternate test device is the specific vehicle into which the built-in system is fabricated. The following test conditions apply to this alternate test device.

(A) The vehicle is loaded to its unloaded vehicle weight plus its rated cargo and luggage capacity weight, secured in the luggage area, plus the appropriate child test dummy and, at the vehicle manufacturer's option, an anthropomorphic test dummy which conforms to the requirements of subpart B or subpart E of part 572 of this title for a 50th percentile adult male dummy placed in the front outboard seating position. If the built-in child restraint system is installed at one of the seating positions otherwise requiring the placement of a part 572 test dummy, then in the frontal barrier crash specified in paragraph (c) of this section, the appropriate child test dummy shall be substituted for the part 572 adult dummy, but only at that seating position. The fuel tank is filled to any level from 90 to 95 percent of capacity.

(B) Adjustable seats are in the adjustment position midway between the forward-most and rearmost positions, and if separately adjustable in a vehicle direction, are at the lowest position. If an adjustment position does not exist midway between the forward-most and rearmost positions, the closest adjustment position to the rear of the midpoint is used.

(C) Adjustable seat backs are in the manufacturer's nominal design riding position. If a nominal position is not specified, the seat back is positioned so that the longitudinal center line of the child test dummy's neck is vertical, and if an anthropomorphic test dummy is used, the accelerometer surfaces in the test dummy's head and thorax, as positioned in the vehicle, are horizontal. If the vehicle is equipped with adjustable head restraints, each is adjusted to its highest adjustment position.

(D) Movable vehicle windows and vents are, at the manufacturer's option, placed in the fully closed position.

(E) Convertibles and open-body type vehicles have the top, if any, in place in the closed passenger compartment configuration.

(F) Doors are fully closed and latched but not locked.

(G) All instrumentation and data reduction are in conformance with SAE Recommended Practice J211/1, (incorporated by reference, see § 571.5).

(b) The tests are frontal barrier impact simulations of the test platform or frontal barrier crashes of the specific vehicles as specified in S5.1 of § 571.208 and for:

(1) Test Configuration I, are at a velocity change of 48 km/h with the acceleration of the test platform entirely within the curve shown in Figure 2, or for the specific vehicle test with the deceleration produced in a 48 km/h frontal barrier crash.

(2) Test Configuration II, are set at a velocity change of 32 km/h with the acceleration of the test platform entirely within the curve shown in Figure 3, or for the specific vehicle test, with the deceleration produced in a 32 km/h frontal barrier crash.

(c) As illustrated in Figures 1A and 1B of this standard, attached to the seat belt anchorage points provided on the standard seat assembly are Type 1 or Type 2 seat belt assemblies. These seat belt assemblies meet the requirements of Standard No. 209 (§ 571.209) and have webbing with a width of not more than 2 inches, and are attached to the anchorage points without the use of retractors or reels of any kind. As illustrated in Figures 1A' and 1B' of this standard, attached to the standard seat assembly is a child restraint anchorage system conforming to the specifications of Standard No. 225 (§ 571.225).

(d)(1) When using the test dummy specified in 49 CFR part 572, subparts I and K, performance tests under S6.1 are conducted at any ambient temperature from 19 °C to 26 °C and at any relative humidity from 10 percent to 70 percent.

(2) When using the test dummies specified in 49 CFR part 572, subpart N, P, R or T, performance tests under S6.1 are conducted at any ambient temperature from 20.6 °C to 22.2 °C and at any relative humidity from 10 percent to 70 percent.

(e) In the case of add-on child restraint systems, the restraint shall meet the requirements of S5 at each of its seat back angle adjustment positions and restraint belt routing positions, when

the restraint is oriented in the direction recommended by the manufacturer (e.g., forward, rearward or laterally) pursuant to S5.6, and tested with the test dummy specified in S7.

S6.1.2 *Dynamic test procedure.* (a) Activate the built-in child restraint system or attach the add-on child restraint system to the seat assembly in any of the following manners, at the agency's option.

(1) *Test configuration I.* (i) *Child restraint systems other than booster seats.* At the agency's option, attach the child restraint in any of the following manners specified in S6.1.2(a)(1)(i)(A) through (D), unless otherwise specified in this standard. The child restraint system must meet the requirements of the standard when attached in any of these manners, subject to S6.1.2.

(A) Install the child restraint system on the standard seat assembly, in accordance with the manufacturer's instructions provided with the system pursuant to S5.6.1, except that, at the agency's option, the standard lap belt is used or the lap and shoulder belt is used. If provided, a tether strap may be used, but only if the manufacturer's instructions instruct consumers to use it. Attach the school bus child restraint system in accordance with the manufacturer's instructions provided with the system pursuant to S5.6.1, e.g., the seat back mount or seat back and seat pan mount are used.

(B) Except for a child harness, a school bus child restraint system, and a restraint designed for use by children with physical disabilities, install the child restraint system on the standard seat assembly as in S6.1.2(a)(1)(i)(A), except that no tether strap (or any other supplemental device) is used.

(C) Install the child restraint system using the child restraint anchorage system on the standard seat assembly in accordance with the manufacturer's instructions provided with the system pursuant to S5.6.1. The tether strap, if one is provided, is attached to the tether anchorage.

(D) Install the child restraint system using only the lower anchorages of the child restraint anchorage system as in S6.1.2(a)(1)(i)(C). No tether strap (or any other supplemental device) is used.

(ii) *Booster seats.* A booster seat is placed on the standard seat assembly in accordance with the manufacturer's instructions provided with the system pursuant to S5.6.1. The booster seat is dynamically tested using only the standard vehicle lap and shoulder belt and no tether (or any other supplemental device). At NHTSA's option, the ATD Head Protection Device depicted in NHTSA Standard Seat Assembly; FMVSS No. 213, No. NHTSA-213-2021, (March 2023), (incorporated by reference, see § 571.5) can be used when testing backless child restraint systems. Place the booster seat on the standard seat assembly such that the center plane of the booster seat is parallel and aligned to the center plane of the standard seat assembly and the base of the booster seat is flat on the standard seat assembly cushion. Move the booster seat rearward on the standard seat assembly until some part of the booster seat touches the standard seat assembly back. Keep the booster seat and the seating position center plane aligned as much as possible. Apply 133 N (30 pounds) of force to the front of the booster seat rearward into the standard seat assembly and release.

(iii) In the case of each built-in child restraint system, activate the restraint in the specific vehicle shell or the specific vehicle, in accordance with the manufacturer's instructions provided in accordance with S5.6.2.

(2) *Test configuration II.* (i) In the case of each add-on child restraint system which is equipped with a fixed or movable surface described in S5.2.2.2, install the add-on child restraint system onto the standard seat assembly using only the standard seat lap belt or the lap and shoulder belt to secure the system to the standard seat, or at NHTSA's option, only the lower anchorages of the child restraint anchorage system. Do not attach the top tether.

(ii) In the case of each built-in child restraint system which is equipped with a fixed or movable surface described in S5.2.2.2 that has belts that are not an integral part of that fixed or

movable surface, activate the system in the specific vehicle shell or the specific vehicle in accordance with the manufacturer's instructions provided in accordance with S5.6.2.

(b) Select any dummy specified in S7 for testing systems for use by children of any height or any weight for which the system is recommended in accordance with S5.5. The dummy is assembled, clothed and prepared as specified in S7 and S9 and part 572 of this chapter, as appropriate.

(c) Place the dummy in the child restraint system. Position it, and attach the child restraint system belts, if appropriate, as specified in S10.

(d)(1) The belts of add-on systems other than belt-positioning seats are adjusted as follows.

(i) Shoulder and pelvic belts that directly restrain the dummy are adjusted as follows: Tighten the belt system used to restrain the child within the child restraint system to any tension of not less than 9 Newtons and not more than 18 Newtons on the webbing at the top of each dummy shoulder and the pelvic region.

(ii) All Type 1 or Type 2 belt systems used to attach an add-on child restraint system to the standard seat assembly are tightened to any tension of not less than 53.5 N and not more than 67 N. Tighten any provided additional anchorage belt (top tether) to any tension of not less than 45 Newtons and not more than 53.5 Newtons. All belt systems used to attach a school bus child restraint system are also tightened to any tension of not less than 53.5 N and not more than 67 N.

(iii) When using the child restraint anchorage system to attach the child restraint system to the standard seat assembly, tighten the belt systems of the lower anchorage attachments used to attach the restraint to the standard seat assembly to any tension of not less than 53.5 Newtons and not more than 67 Newtons and tighten the belt of the top tether attachment used to attach the restraint to the standard seat assembly to any tension of not less than 45 Newtons and not more than 53.5 Newtons.

(2) The belts of add-on belt-positioning seats are adjusted as follows.

(i) The lap portion of Type 2 belt systems used to restrain the dummy is tightened to a tension of not less than 9 N and not more than 18 N.

(ii) The shoulder portion of Type 2 belt systems used to restrain the dummy is tightened to a tension of not less than 9 N and not more than 18 N.

(3) The belts of built-in child restraint systems are adjusted as follows.

(i) The lap portion of Type 2 belt systems used to restrain the dummy is tightened to a tension of not less than 9 N and not more than 18 N.

(ii) The shoulder portion of Type 2 belt systems used to restrain the dummy is tightened to a tension of not less than 9 N and not more than 18 N.

(iii) For built-in child restraint systems, if provided, shoulder and pelvic belts that directly restrain the dummy are adjusted as follows. Tighten the belt system used to restrain the child within the child restraint system to any tension of not less than 9 Newtons and not more than 18 Newtons on the webbing at the top of each dummy shoulder and the pelvic region.

(e) Accelerate the test platform to simulate frontal impact in accordance with Test Configuration I or II, as appropriate.

(f) Determine conformance with the requirements in S5.1.

S6.2 Buckle release test procedure. The belt assembly buckles used in any child restraint system shall be tested in accordance with S6.2.1 through S6.2.4 inclusive.

S6.2.1 Before conducting the testing specified in S6.1, place the loaded buckle on a hard, flat, horizontal surface. Each belt end of the buckle shall be pre-loaded in the following manner. The anchor end of the buckle shall be loaded with a 9 N force in the direction away from the buckle. In the case of buckles designed to secure a single latch plate, the belt latch plate end of the buckle shall be pre-loaded with a 9 N force in the direction away from the buckle. In the case of buckles designed to secure two or more latch plates, the belt latch plate ends of the buckle shall be loaded equally so that the total load is 9 N, in the direction away from the buckle. For pushbutton-release buckles, the release force shall be applied by a conical surface (cone angle

not exceeding 90 degrees). For pushbutton-release mechanisms with a fixed edge (referred to in Figure 7 as “hinged button”), the release force shall be applied at the centerline of the button, 3 mm away from the movable edge directly opposite the fixed edge, and in the direction that produces maximum releasing effect. For pushbutton-release mechanisms with no fixed edge (referred to in Figure 7 as “floating button”), the release force shall be applied at the center of the release mechanism in the direction that produces the maximum releasing effect. For all other buckle release mechanisms, the force shall be applied on the centerline of the buckle lever or finger tab in the direction that produces the maximum releasing effect. Measure the force required to release the buckle. Figure 7 illustrates the loading for the different buckles and the point where the release force should be applied, and Figure 8 illustrates the conical surface used to apply the release force to pushbutton-release buckles.

S6.2.2 After completion of the testing specified in S6.1 and before the buckle is unlatched, tie a self-adjusting sling to each wrist and ankle of the test dummy in the manner illustrated in Figure 4, without disturbing the belted dummy and the child restraint system.

S6.2.3 Pull the sling tied to the dummy restrained in the child restraint system and apply the following force: 50 N for a system tested with a newborn dummy (49 CFR part 572, subpart K); 90 N for a system tested with a 12-month-old dummy (49 CFR part 572, subpart R); 200 N for a system tested with a 3-year-old dummy (49 CFR part 572, subpart P); 270 N for a system tested with a 6-year-old dummy (49 CFR part 572, subpart N or I); 350 N for a system tested with a weighted 6-year-old dummy (49 CFR part 572, subpart S); or 437 N for a system tested with a 10-year-old dummy (49 CFR part 572, subpart T). The force is applied in the manner illustrated in Figure 4 and as follows:

(a) *Add-on child restraint systems.* For an add-on child restraint system other than a car bed, apply the specified force by pulling the sling horizontally and parallel to the SORL of the standard seat assembly. For a car bed, apply the force by pulling the sling vertically.

(b) *Built-in child restraint systems.* For a built-in child restraint systems other than a car bed, apply the force by pulling the sling parallel to the longitudinal centerline of the specific vehicle shell or the specific vehicle. In the case of a car bed, apply the force by pulling the sling vertically.

S6.2.4 While applying the force specified in S6.2.3, and using the device shown in Figure 8 for pushbutton-release buckles, apply the release force in the manner and location specified in S6.2.1, for that type of buckle. Measure the force required to release the buckle.

S6.3 [Reserved]

S7 Test dummies. (Subparts referenced in this section are of part 572 of this chapter.)

S7.1 Dummy selection. Select any dummy specified in S7.1.1, S7.1.2 or S7.1.3, as appropriate, for testing systems for use by children of the height (regardless of weight) or weight (regardless of height) for which the system is recommended in accordance with S5.5. A child restraint system that meets the criteria in two or more of the following paragraphs in S7 may be tested with any of the test dummies specified in those paragraphs.

S7.1.1 [Reserved]

S7.1.2 Child restraints systems are subject to the following provisions and S7.1.3.

(a) A child restraint system that is recommended by its manufacturer in accordance with S5.5 for use either by children in a specified weight range that includes any children having a weight of not greater than 5 kg (11 lb) regardless of height, or by children in a specified height range that includes any children whose height is not greater than 650 mm regardless of weight, is tested with a 49 CFR part 572 subpart K dummy (newborn infant dummy).

(b) A child restraint system that is recommended by its manufacturer in accordance with S5.5 for use either by children in a specified weight range that includes any children having a weight greater than 5 kg (11 lb) but not greater than 10 kg (22 lb) regardless of height, or by children in a specified height range that includes any children whose height is greater than 650 mm but not greater than 750 mm regardless of weight, is tested with a 49 CFR part 572 subpart

K dummy (newborn infant dummy), and a part 572 subpart R dummy (CRABI 12-month-old test dummy).

(c) A child restraint system that is recommended by its manufacturer in accordance with S5.5 for use either by children in a specified weight range that includes any children having a weight greater than 10 kg (22 lb) but not greater than 13.6 kg (30 lb) regardless of height, or by children in a specified height range that includes any children whose height is greater than 750 mm but not greater than 870 mm regardless of weight, is tested with a part 572 subpart R dummy (CRABI 12-month-old test dummy), provided, however, that the CRABI 12-month-old dummy is not used to test a forward-facing child restraint system.

(d) A child restraint system that is recommended by its manufacturer in accordance with S5.5 for use either by children in a specified weight range that includes any children having a weight greater than 13.6 kg (30 lb) but not greater than 18.2 kg (40 lb) regardless of height, or by children in a specified height range that includes any children whose height is greater than 870 mm but not greater than 1100 mm regardless of weight, is tested with a 49 CFR part 572, subpart P dummy (Hybrid III 3-year-old dummy).

(e) A child restraint system that is recommended by its manufacturer in accordance with S5.5 for use either by children in a specified weight range that includes any children having a weight greater than 18.2 kg (40 lb) but not greater than 22.7 kg (50 lb) regardless of height, or by children in a specified height range that includes any children whose height is greater than 1100 mm but not greater than 1250 mm regardless of weight, is tested with a 49 CFR part 572, subpart N dummy (Hybrid III 6-year-old dummy).

(f) A child restraint system that is recommended by its manufacturer in accordance with S5.5 for use either by children in a specified weight range that includes any children having a weight greater than 22.7 kg (50 lb) but not greater than 30 kg (65 lb) regardless of height, or by children in a specified height range that includes any children whose height is greater than 1100 mm but not greater than 1250 mm regardless of weight, is tested with a 49 CFR part 572, subpart

N dummy (Hybrid III 6-year-old dummy) and with a part 572, subpart S dummy (Hybrid III 6-year-old weighted dummy).

(g) A child restraint system that is recommended by its manufacturer in accordance with S5.5 for use either by children in a specified weight range that includes any children having a weight greater than 30 kg (65 lb) regardless of height, or by children in a specified height range that includes any children whose height is greater than 1250 mm regardless of weight, is tested with a 49 CFR part 572, subpart T dummy (Hybrid III 10-year-old dummy).

S8 Requirements, test conditions, and procedures for child restraint systems manufactured for use in aircraft. Each child restraint system manufactured for use in both motor vehicles and aircraft must comply with all of the applicable requirements specified in Section S5 and with the additional requirements specified in S8.1 and S8.2.

S8.1 Installation instructions. Each child restraint system manufactured for use in aircraft shall be accompanied by printed instructions in English that provide a step-by-step procedure, including diagrams, for installing the system in aircraft passenger seats, securing a child in the system when it is installed in aircraft, and adjusting the system to fit the child.

S8.2 Inversion test. When tested in accordance with S8.2.1 through S8.2.5, each child restraint system manufactured for use in aircraft shall meet the requirements of S8.2.1 through S8.2.6. The manufacturer may, at its option, use any seat which is a representative aircraft passenger seat within the meaning of S4. Each system shall meet the requirements at each of the restraint's seat back angle adjustment positions and restraint belt routing positions, when the restraint is oriented in the direction recommended by the manufacturer (e.g., facing forward, rearward or laterally) pursuant to S8.1, and tested with the test dummy specified in S7. If the manufacturer recommendations do not include instructions for orienting the restraint in aircraft when the restraint seat back angle is adjusted to any position, position the restraint on the aircraft seat by following the instructions (provided in accordance with S5.6) for orienting the restraint in motor vehicles.

S8.2.1 A standard seat assembly consisting of a representative aircraft passenger seat shall be positioned and adjusted so that its horizontal and vertical orientation and its seat back angle are the same as shown in Figure 6.

S8.2.2 The child restraint system shall be attached to the representative aircraft passenger seat using, at the manufacturer's option, any Federal Aviation Administration approved aircraft safety belt, according to the restraint manufacturer's instructions for attaching the restraint to an aircraft seat. No supplementary anchorage belts or tether straps may be attached; however, Federal Aviation Administration approved safety belt extensions may be used.

S8.2.3 In accordance with S10, place in the child restraint system any dummy specified in S7 for testing systems for use by children of the heights and weights for which the system is recommended in accordance with S5.5 and S8.1.

S8.2.4 If provided, shoulder and pelvic belts that directly restrain the dummy shall be adjusted in accordance with S6.1.2.

S8.2.5 The combination of representative aircraft passenger seat, child restraint system, and test dummy shall be rotated forward around a horizontal axis which is contained in the median transverse vertical plane of the seating surface portion of the aircraft seat and is located 25 mm below the bottom of the seat frame, at a speed of 35 to 45 degrees per second, to an angle of 180 degrees. The rotation shall be stopped when it reaches that angle and the seat shall be held in this position for three seconds. The child restraint system shall not fall out of the aircraft safety belt nor shall the test dummy fall out of the child restraint system at any time during the rotation or the three second period. The specified rate of rotation shall be attained in not less than one half second and not more than one second, and the rotating combination shall be brought to a stop in not less than one half second and not more than one second.

S8.2.6 Repeat the procedures set forth in S8.2.1 through S8.2.4. The combination of the representative aircraft passenger seat, child restraint system, and test dummy shall be rotated sideways around a horizontal axis which is contained in the median longitudinal vertical plane of

the seating surface portion of the aircraft seat and is located 25 mm below the bottom of the seat frame, at a speed of 35 to 45 degrees per second, to an angle of 180 degrees. The rotation shall be stopped when it reaches that angle and the seat shall be held in this position for three seconds. The child restraint system shall not fall out of the aircraft safety belt nor shall the test dummy fall out of the child restraint system at any time during the rotation or the three second period. The specified rate of rotation shall be attained in not less than one half second and not more than one second, and the rotating combination shall be brought to a stop in not less than one half second and not more than one second.

S9 Dummy clothing and preparation.

S9.1 Type of clothing.

(a) *Newborn dummy (49 CFR part 572, subpart K).* When used in testing under this standard, the dummy is unclothed.

(b) [Reserved]

(c) *12-month-old dummy (49 CFR part 572, subpart R).* When used in testing under this standard, the dummy specified in 49 CFR part 572, subpart R, is clothed in a cotton-polyester based tight fitting sweatshirt with long sleeves and ankle long pants whose combined weight is not more than 0.25 kg.

(d) [Reserved]

(e) *Hybrid III 3-year-old dummy (49 CFR part 572, subpart P).* When used in testing under this standard, the dummy specified in 49 CFR part 572, subpart P, is clothed as specified in that subpart, except that the shoes are children's size 8 canvas oxford style sneakers weighing not more than 0.26 kg each.

(f) *Hybrid III 6-year-old dummy (49 CFR part 572, subpart N) and Hybrid III 6-year-old weighted dummy (49 CFR part 572, subpart S), and Hybrid III 10-year-old dummy (49 CFR part 572, subpart T).* When used in testing under this standard, the dummies specified in 49 CFR part 572, subparts N and S, are clothed as specified in subpart N and with child or youth size 13 M

sneakers weighing not more than 0.45 kg each. When used in testing under this standard, the dummy specified in 49 CFR part 572, subpart T, is clothed as specified in subpart T and with youth size 3 sneakers weighing not more than 0.6 kg each.

S9.2 Preparing clothing. Clothing other than the shoes is machined-washed in 71 °C to 82 °C and machine-dried at 49 °C to 60 °C for 30 minutes.

S9.3 Preparing dummies. (Subparts referenced in this section are of part 572 of this chapter.)

S9.3.1 When using the test dummy conforming to subpart K, prepare the dummy as specified in this paragraph. Before being used in testing under this standard, the dummy must be conditioned at any ambient temperature from 19 °C to 25.5 °C and at any relative humidity from 10 percent to 70 percent, for at least 4 hours.

S9.3.2 When using the test dummies conforming to subparts N, P, R, S or T, prepare the dummies as specified in this paragraph. Before being used in testing under this standard, dummies must be conditioned at any ambient temperature from 20.6° to 22.2°C and at any relative humidity from 10 percent to 70 percent, for at least 4 hours.

S10 Positioning the dummy and attaching the system belts.

S10.1 Car beds. Place the test dummy in the car bed in the supine position with its midsagittal plane perpendicular to the center SORL of the standard seat assembly, in the case of an add-on car bed, or perpendicular to the longitudinal axis of the specific vehicle shell or the specific vehicle, in the case of a built-in car bed. Position the dummy within the car bed in accordance with the instructions for child positioning that the bed manufacturer provided with the bed in accordance with S5.6.

S10.2 Restraints other than car beds.

S10.2.1 Newborn dummy and 12-month-old dummy. Position the test dummy according to the instructions for child positioning that the manufacturer provided with the system under S5.6.1 or S5.6.2, while conforming to the following:

(a) [Reserved]

(b) When testing rear-facing child restraint systems, place the newborn, or 12-month-old dummy in the child restraint system so that the back of the dummy torso contacts the back support surface of the system. For a child restraint system which is equipped with a fixed or movable surface described in S5.2.2.2 which is being tested under the conditions of test configuration II, do not attach any of the child restraint system belts unless they are an integral part of the fixed or movable surface. For all other child restraint systems and for a child restraint system with a fixed or movable surface which is being tested under the conditions of test configuration I, attach all appropriate child restraint system belts and tighten them as specified in S6.1.2. Attach all appropriate vehicle belts and tighten them as specified in S6.1.2. Position each movable surface in accordance with the instructions that the manufacturer provided under S5.6.1 or S5.6.2. If the dummy's head does not remain in the proper position, tape it against the front of the seat back surface of the system by means of a single thickness of 6 mm-wide paper masking tape placed across the center of the dummy's face.

(c) When testing rear-facing child restraint systems, extend the dummy's arms vertically upwards and then rotate each arm downward toward the dummy's lower body until the arm contacts a surface of the child restraint system or the standard seat assembly in the case of an add-on child restraint system, or the specific vehicle shell or the specific vehicle, in the case of a built-in child restraint system. Ensure that no arm is restrained from movement in other than the downward direction, by any part of the system or the belts used to anchor the system to the standard seat assembly, the specific shell, or the specific vehicle.

S10.2.2 *Other dummies generally.* When using: (1) the Hybrid III 3-year-old (part 572, subpart P), and Hybrid III weighted 6-year-old (part 572, subpart S) in child restraint systems including belt-positioning seats; (2) the Hybrid III 6-year-old (part 572, subpart N) and the Hybrid III 10-year-old (part 572, subpart T) in child restraint systems other than belt-positioning

seats, position the dummy in accordance with S5.6.1 or S5.6.2, while conforming to the following:

(a) Holding the test dummy torso upright until it contacts the system's design seating surface, place the test dummy in the seated position within the system with the midsagittal plane of the test dummy head -

(1) Coincident with the center SORL of the standard seating assembly, in the case of the add-on child restraint system, or

(2) Vertical and parallel to the longitudinal center line of the specific vehicle, in the case of a built-in child restraint system.

(b) Extend the arms of the test dummy as far as possible in the upward vertical direction. Extend the legs of the dummy as far as possible in the forward horizontal direction, with the dummy feet perpendicular to the center line of the lower legs.

(c) Using a flat square surface with an area of 2580 square millimeters, apply a force of 178 N, perpendicular to:

(1) The plane of the back of the standard seat assembly, in the case of an add-on system, or

(2) The back of the vehicle seat in the specific vehicle shell or the specific vehicle, in the case of a built-in system, first against the dummy crotch and then at the dummy thorax in the midsagittal plane of the dummy. For a child restraint system with a fixed or movable surface described in S5.2.2.2, which is being tested under the conditions of test configuration II, do not attach any of the child restraint system belts unless they are an integral part of the fixed or movable surface. For all other child restraint systems and for a child restraint system with a fixed or movable surface which is being tested under the conditions of test configuration I, attach all appropriate child restraint system belts and tighten them as specified in S6.1.2. Attach all appropriate vehicle belts and tighten them as specified in S6.1.2. Position each movable surface in accordance with the instructions that the manufacturer provided under S5.6.1 or S5.6.2.

(d) After the steps specified in paragraph (c) of this section, rotate each dummy limb downwards in the plane parallel to the dummy's midsagittal plane until the limb contacts a surface of the child restraint system or the standard seat assembly, in the case of an add-on system, or the specific vehicle shell or specific vehicle, in the case of a built-in system, as appropriate. Position the limbs, if necessary, so that limb placement does not inhibit torso or head movement in tests conducted under S6.

(e) Additional provisions when using the Hybrid III 3-year-old (part 572, subpart P) dummy in a rear-facing child restraint system.

(1) When using the Hybrid III 3-year-old dummy in a rear-facing child restraint system with an internal harness or other components to restrain the child, remove the knee stop screw (as shown in drawing 210-6516 of Drawing No. 210-5000-1 (L),-2(R), Leg Assembly in subpart P of part 572 of this chapter (incorporated by reference, see § 571.5) from the right and left knee so as to let the knees hyperextend.

(2) Place the subpart P dummy in the child restraint system being tested so that the back of the dummy torso contacts the back support surface of the system. For a child restraint system equipped with a fixed or movable surface described in S5.2.2.2 that is being tested under the conditions of test configuration II, do not attach any of the child restraint system belts unless they are an integral part of the fixed or movable surface. For all other child restraint systems and for a child restraint system with a fixed or movable surface that is being tested under the conditions of test configuration I, attach all appropriate child restraint system belts and tighten them as specified in S6.1.2. Attach all appropriate vehicle belts and tighten them as specified in S6.1.2. Position each movable surface in accordance with the instructions that the manufacturer provided under S5.6.1 or S5.6.2.

S10.2.3 Hybrid III 6-year-old in belt-positioning seats, Hybrid III weighted 6-year-old in belt-positioning seats, and Hybrid III 10-year-old in belt-positioning seats. When using the Hybrid III 6-year-old (part 572, subpart N), the Hybrid III weighted 6-year-old (part 572, subpart

S), or the Hybrid III 10-year-old (part 572, subpart T) in belt-positioning seats, position the dummy in accordance with S5.6.1 or S5.6.2, while conforming to the following:

(a) *Prepare the dummy.* (1) When using the Hybrid III 10-year-old dummy, prepare the dummy according to the following:

(i) Set the dummy's neck angle at the SP-16 setting (“SP” means standard procedure), see Figure 14a.

(ii) Set the dummy's lumbar angle at the SP-12 setting, see Figure 14b. This is done by aligning the notch on the lumbar adjustment bracket with the SP-12 notch on the lumbar attachment.

(iii) Adjust the limb joints to 1-2 g while the torso is in the seated position.

(iv) Apply double-sided tape to the surface of a lap shield, which is a piece of translucent silicone rubber 3 mm \pm 0.5 mm thick (50A durometer) cut to the dimensions specified in Figure 13 in this section. Place the lap shield on the pelvis of the dummy. Align the top of the lap shield with the superior anterior edge of the pelvis skin. Attach the lap shield to the dummy.

(v) Apply double-sided tape to one side of a pelvis positioning pad, which is a 125 \times 95 \times 20 mm (\pm 2 mm tolerance in each of the three dimensions) piece of closed cell (Type 2 according to ASTM D1056-07) (incorporated by reference; see § 571.5) foam or rubber cut from material having the following specifications: compression resistance between 9 to 17 psi in a compression-deflection test specified in ASTM D1056-07 (incorporated by reference; see § 571.5), and a density of 7 to 12.5 lb/ft³. Center the long axis of the pad on the posterior of the pelvis with the top edge of the foam aligned with the superior edge of the pelvis skin. Attach the pelvis positioning pad to the dummy.

(vi) Dress and prepare the dummy according to S9.

(2) When using the Hybrid III 6-year-old dummy and the Hybrid III weighted 6-year-old dummy, prepare the dummy according to the following:

(i) If necessary, adjust the limb joints to 1-2 g while the torso is in the seated position.

(ii) Apply double-sided tape to the surface of a lap shield, which is a piece of translucent silicone rubber 3 mm thick ± 0.5 mm thick (50A durometer) cut to the dimensions specified in Figure 13. Place the lap shield on the pelvis of the dummy. Align the top of the lap shield with the superior anterior edge of the pelvis skin. Attach the lap shield to the dummy.

(iii) Dress and prepare the dummy according to S9.

(b) *Position the belt-positioning seat.* Position the belt-positioning seat according to S6.1.2(a)(1)(ii).

(c) *Position the dummy.* Position the dummy in the belt-positioning seat.

(1) Place the dummy on the seat cushion of the belt-positioning seat such that the plane of the posterior pelvis is parallel to the plane of the seat back of the belt-positioning seat, standard seat assembly or vehicle seat back, but not touching. Pick up and move the dummy rearward, maintaining the parallel planes, until the pelvis positioning pad, if used, or the pelvis or back of the dummy and the back of the belt-positioning seat or the back of the standard seat assembly, are in minimal contact.

(2) Straighten and align the arm segments horizontally, then rotate the arms upward at the shoulder as far as possible without contacting the belt-positioning seat. Straighten and align the legs horizontally and extend the lower legs as far as possible in the forward horizontal direction, with the feet perpendicular to the centerline of the lower legs.

(3) Using a flat square surface with an area of 2580 square millimeters, apply a force of 178 N (40 lb) first against the dummy crotch and then against the dummy thorax on the midsagittal plane of the dummy, perpendicular to:

(i) The plane of the back of the belt-positioning seat, in the case of a belt-positioning seat with a back, or,

(ii) The plane of the back of the standard seat assembly or vehicle seat, in the case of a backless belt-positioning seat or built-in booster.

(4) Rotate the arms of the dummy down so that they are perpendicular to the torso.

(5) Bend the knees until the back of the lower legs are in minimal contact with the belt-positioning seat, standard seat assembly or vehicle seat. Position the legs such that the outer edges of the knees are 180 ± 10 mm apart for the Hybrid III 6-year-old dummy and 220 ± 10 mm apart for the Hybrid III 10-year-old dummy. Position the feet such that the soles are perpendicular to the centerline of the lower legs. In the case of a belt-positioning seat with a back, adjust the dummy so that the shoulders are parallel to a line connecting the shoulder belt guides. This can be accomplished by leaning the torso such that the dummy's head and neck are centered on the backrest components of the belt-positioning seat. In case of a backless child restraint system, adjust the dummy's torso so that the head is as close to laterally level as possible.

(d) *Apply the belt.* Attach the vehicle belts and tighten them as specified in S6.1.2.

(e) *Dummy final positioning.* (1) Check the leg, feet, thorax and head positions and make any necessary adjustments to achieve the positions described in S10.2.3(c)(5). Position the legs, if necessary, so that the leg placement does not inhibit thorax movement in tests conducted under S6.

(2) Rotate each dummy arm downwards in the plane parallel to the dummy's midsagittal plane until the arm contacts a surface of the child restraint system or the standard seat assembly, in the case of an add-on system, or the specific vehicle shell or specific vehicle, in the case of a built-in system, as appropriate. Position the arms, if necessary, so that the arm placement does not inhibit torso or head movement in tests conducted under S6.

Figure 1A-1 to § 571.213b - Seat Orientation Reference Line and Seat Belt

Anchorage Point Locations on the Standard Seat Assembly

(See drawing package referenced in this section for tolerances)

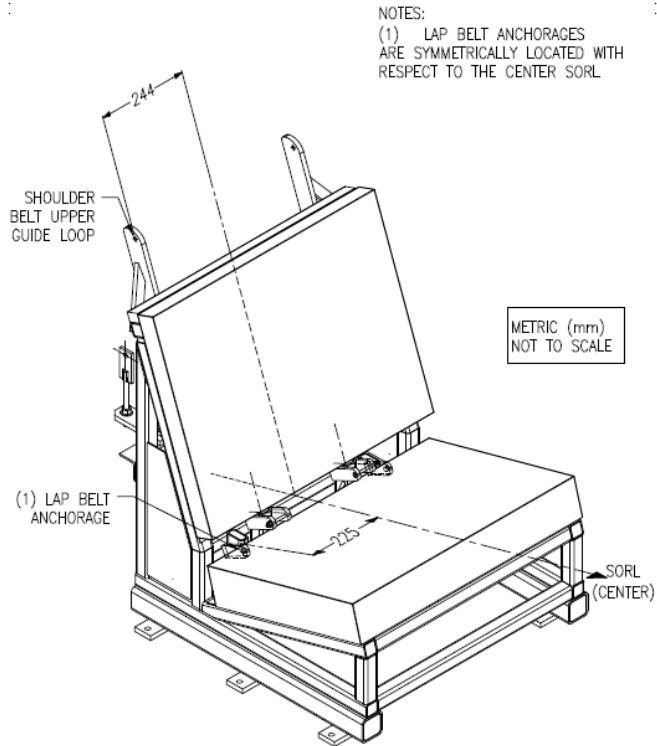

Figure 1A-2 to § 571.213b – Seat Orientation Reference Line and Location of the Lower Anchorages of the Child Restraint Anchorage System on the Standard Seat Assembly
(See drawing package referenced in this standard for tolerances)

NOTES:

(1) LOWER ANCHORAGES 6 mm DIAMETER AND 38 mm LENGTH

(ii) TRANSVERSE HORIZONTAL DISTANCE BETWEEN THE CENTER OF THE LOWER ANCHORAGES AND THE VERTICAL PLANE LOWER CONTAINING SORL AT THE CENTER OF THE SEAT ASSEMBLY IS 140 mm.

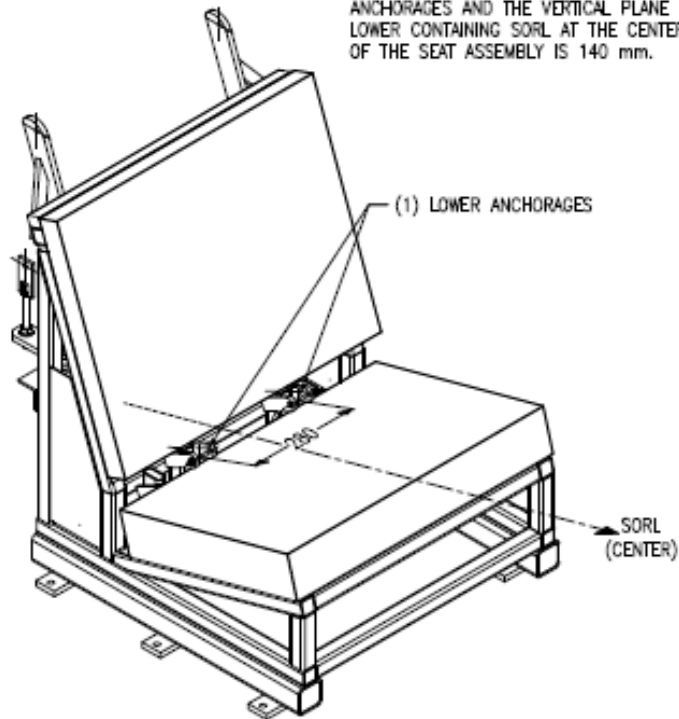
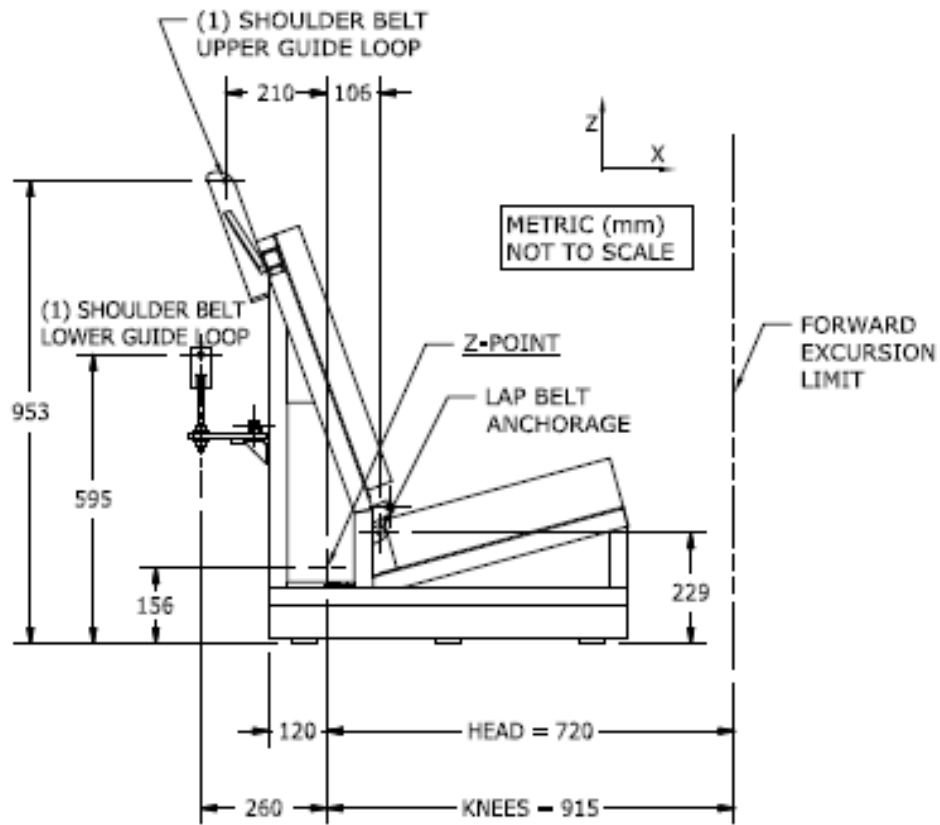
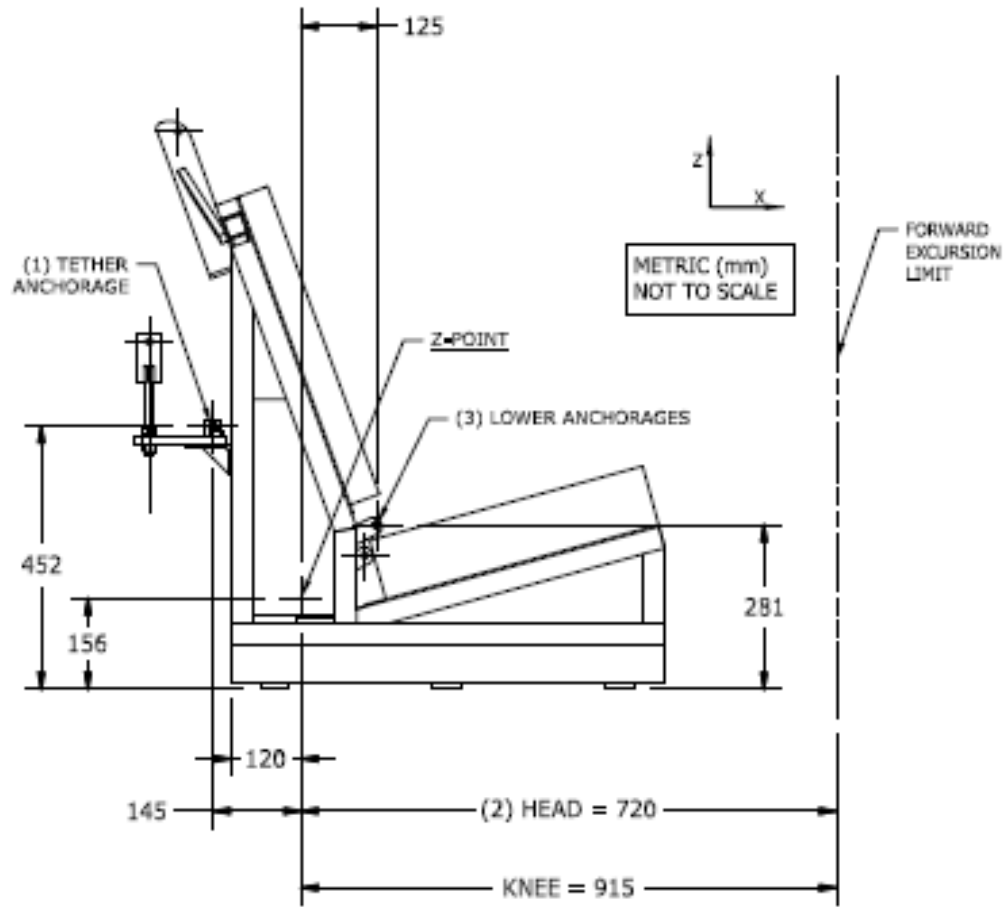

Figure 1B-1 to § 571.213b – Location of Shoulder Belt Upper and Lower Guide Loops and Forward Excursion Limits on the Standard Seat Assembly
 (See drawing package referenced in this standard for tolerances)



NOTES:
 (1) SHOULDER BELT UPPER AND LOWER GUIDE LOOPS ARE LOCATED 244 mm RIGHT AND LEFT OF THE CENTER SORL AS SHOWN IN FIGURE 1A

Figure 1B-2 to § 571.213b – Location of the Child Restraint Anchorages and Forward Excursion Limits on the Standard Seat Assembly
 (See drawing package referenced in this standard for tolerances)



- NOTES:
- (1) TETHER ANCHORAGE LOCATED ON CENTER SORL
 - (2) HEAD EXCURSION LIMIT IS (I) 720 mm WITH TETHER ATTACHED AND (II) 813 mm WITH TETHER UNATTACHED
 - (3) LOWER ANCHORAGES LOCATED 125 mm FORWARD OF Z POINT AND 281 mm UPWARD FROM FLOOR

Figure 1C to § 571.213b – Rear-Facing Child Restraint Forward and Upper Head Excursion Limits

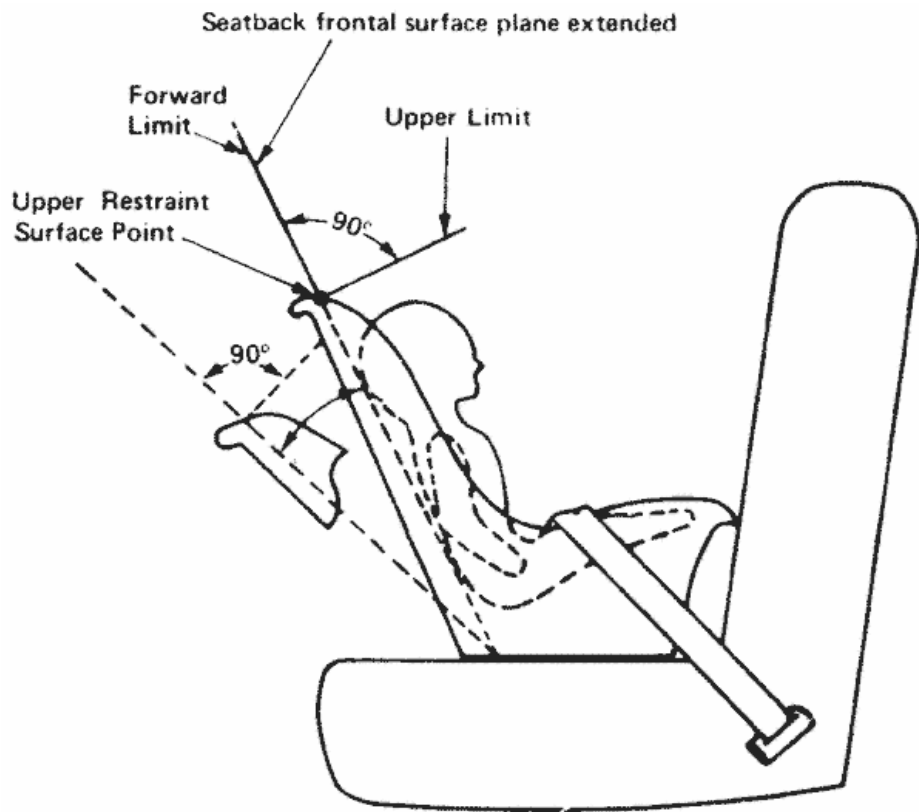

Note: The limits illustrated move during dynamic testing

Figure 2 to § 571.213b

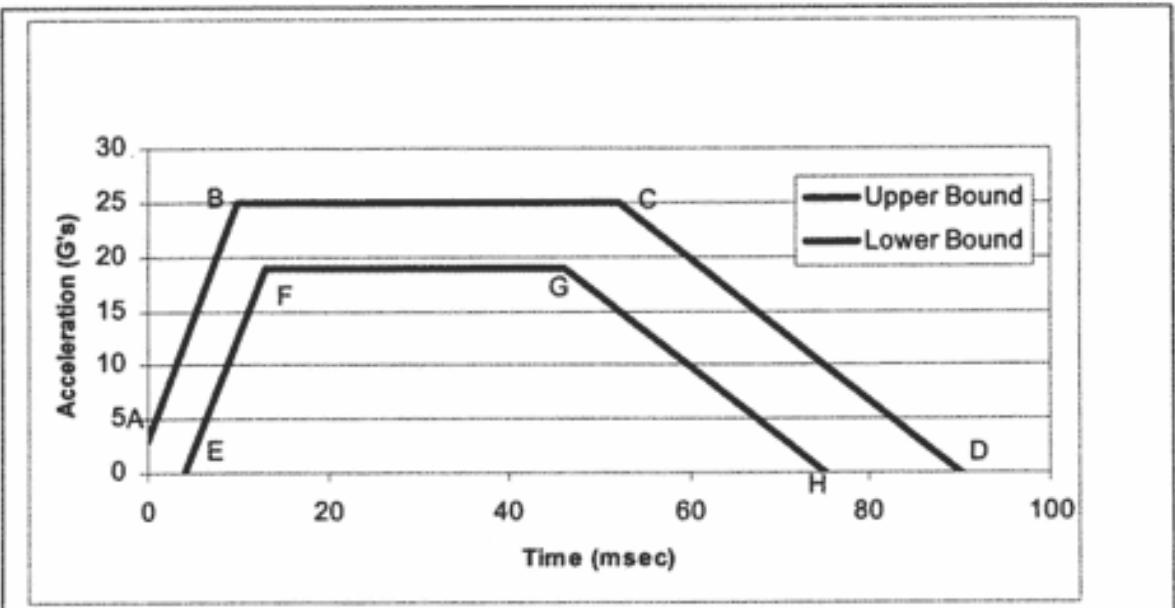

| Upper Bound | | | Lower Bound | | |
|-------------|------|--------------|-------------|------|--------------|
| Point | Time | Acceleration | Point | Time | Acceleration |
| A | 0 | 3 | E | 4 | 0 |
| B | 10 | 25 | F | 13 | 19 |
| C | 52 | 25 | G | 46 | 19 |
| D | 90 | 0 | H | 75 | 0 |

Figure 3 to § 571.213b

Figure 3 to § 571.213b

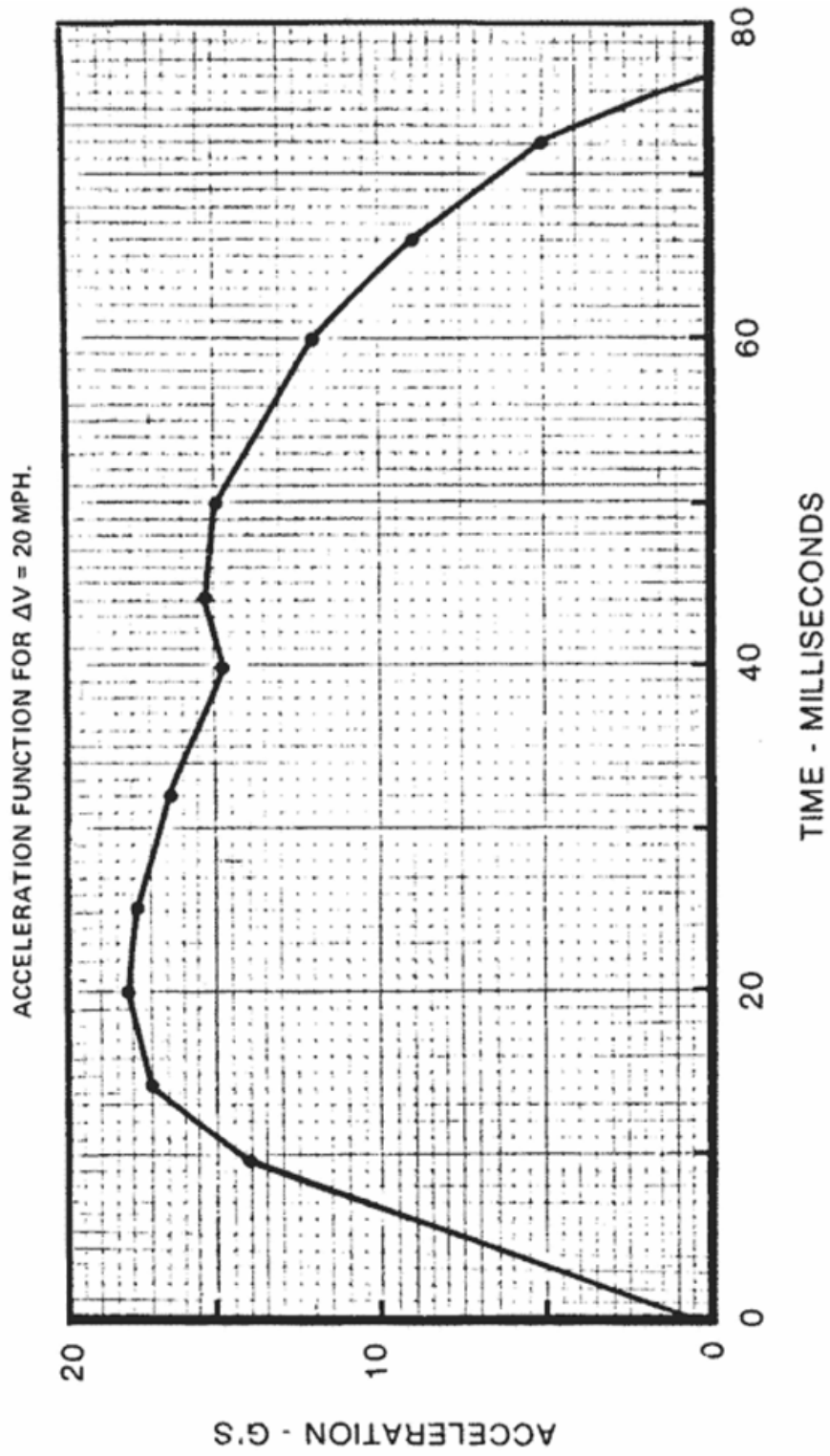
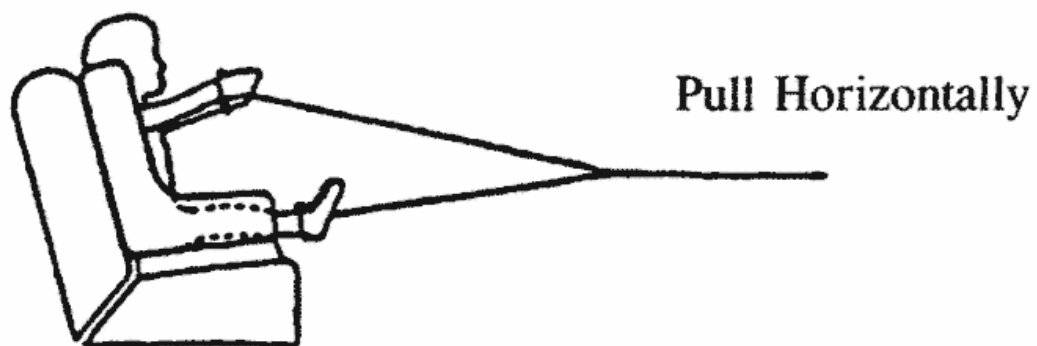

Figure 4 to § 571.213b – Buckle Release Test

a)



b)

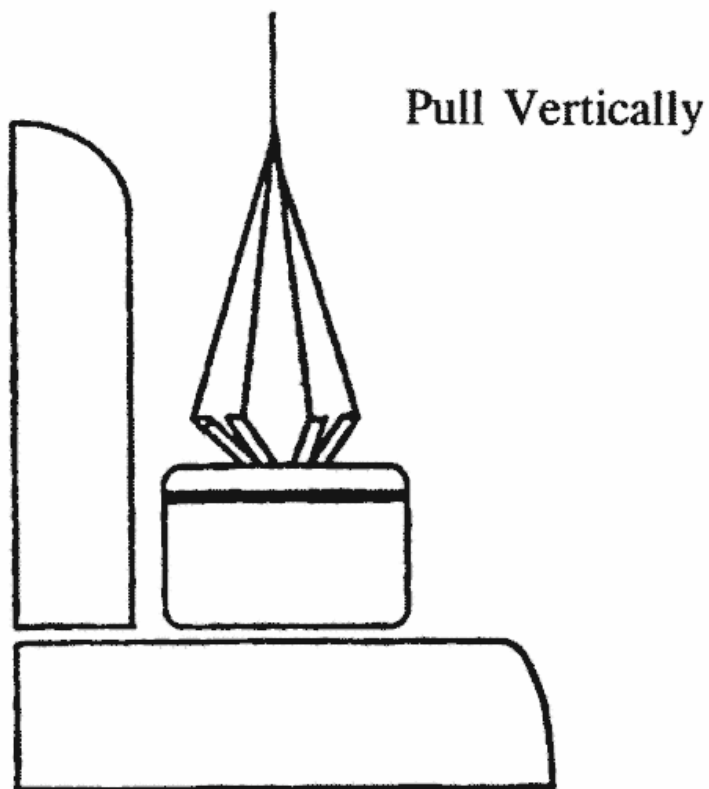
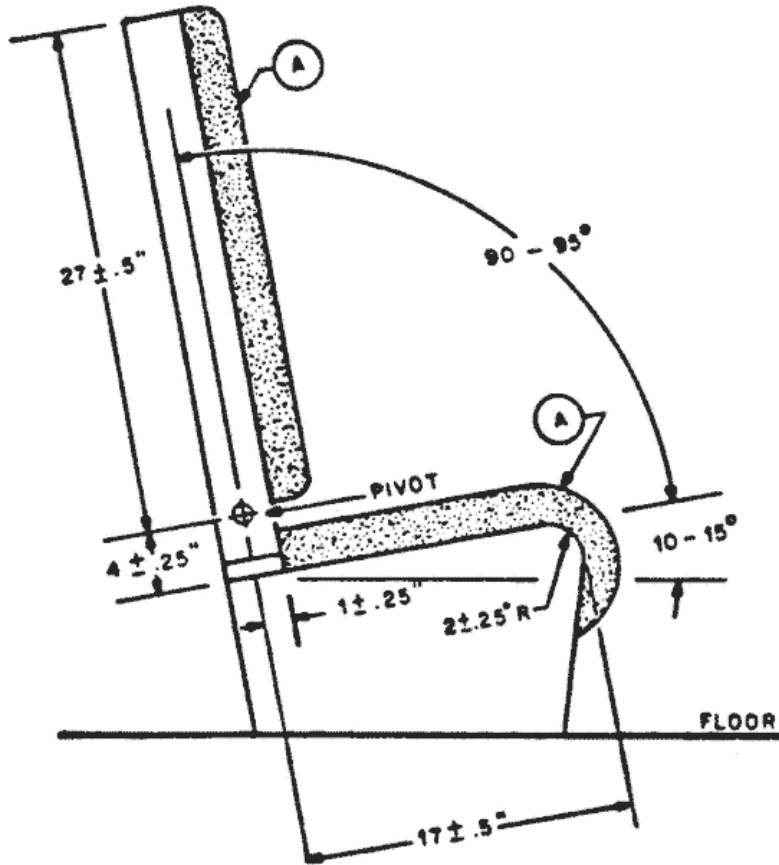

Figure 5 [Reserved]

Figure 6 to § 571.213b -Simulated Aircraft Passenger Seat



"A" represents a 2- to 3-inch thick polyurethane foam pad, 1.5-2.0 pounds per cubic foot density, over 0.020-inch-thick aluminum pan, and covered by 12- to 14-ounce marine canvas. The sheet aluminum pan is 20 inches wide and supported on each side by a rigid structure. The seat back is a rectangular frame covered with the aluminum sheet and weighing between 14 and 15 pounds, with a center of mass 13 to 16 inches above the seat pivot axis. The mass moment of inertia of the seat back about the seat pivot axis is between 195 and 220 ounce-inch-second². The seat back is free to fold forward about the pivot, but a stop prevents rearward motion. The passenger safety belt anchor points are spaced 21 to 22 inches apart and are located in line with the seat pivot axis.

Figure 7 to § 571.213b. Pre-Impact Buckle Release Force Test Set-up

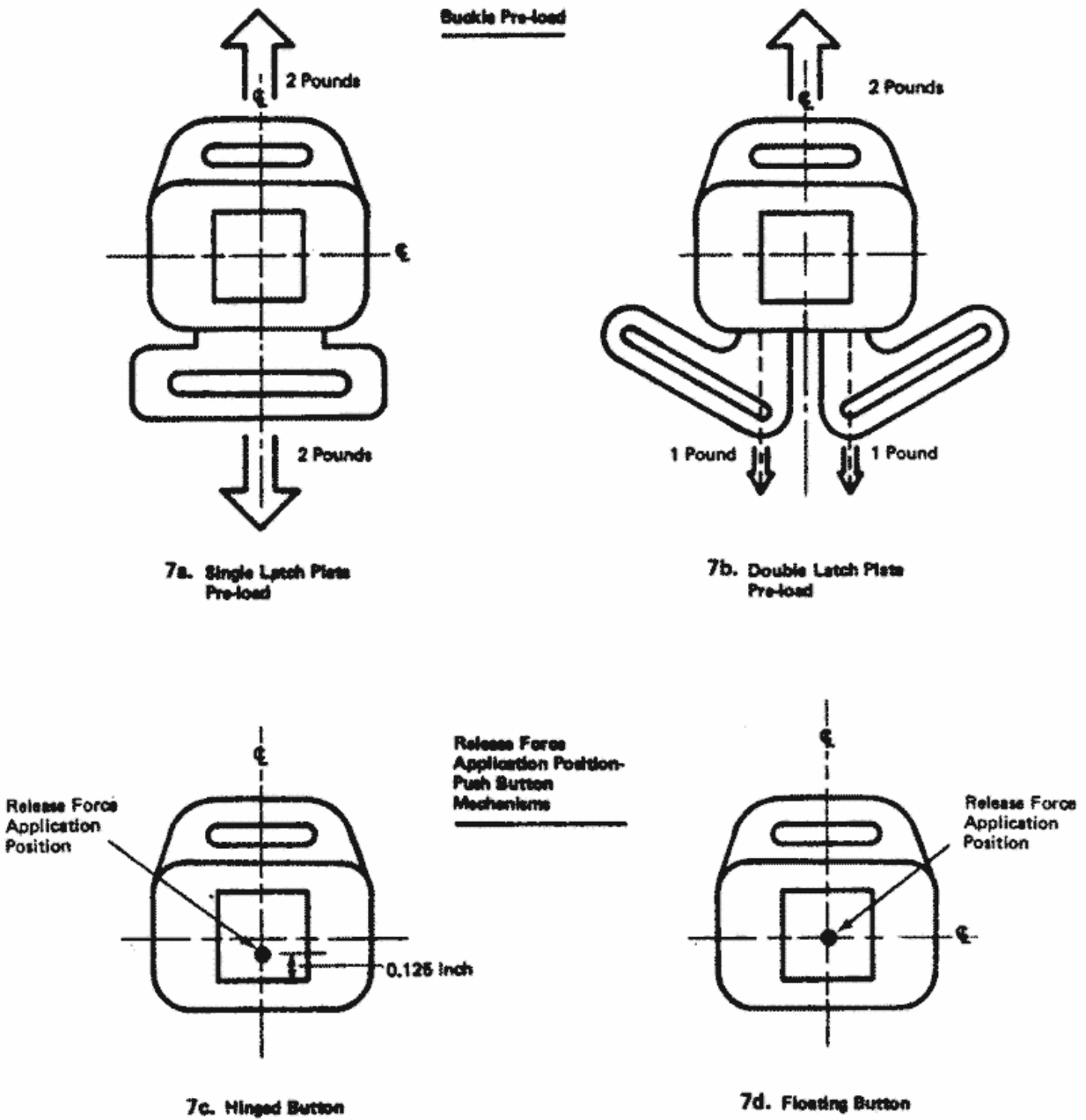

Figure 8 to § 571.213b. Release Force Application Device-Push Button Release Buckles

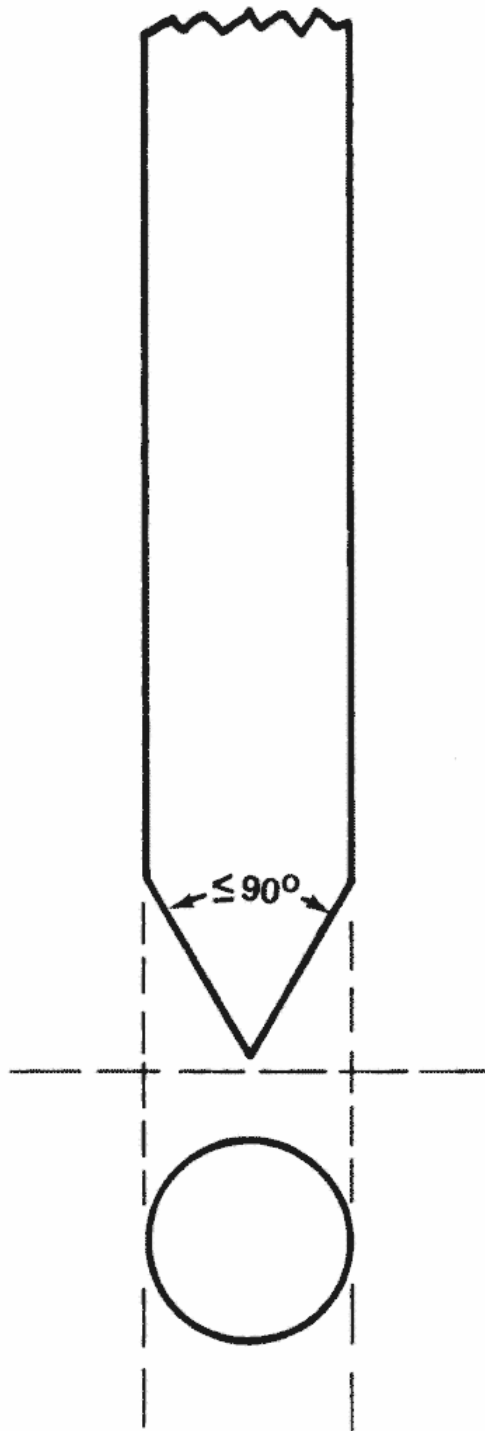

Figure 9a to § 571.213b – Registration Form for Child Restraint Systems – Product Identification Number and Purchaser Information Side.

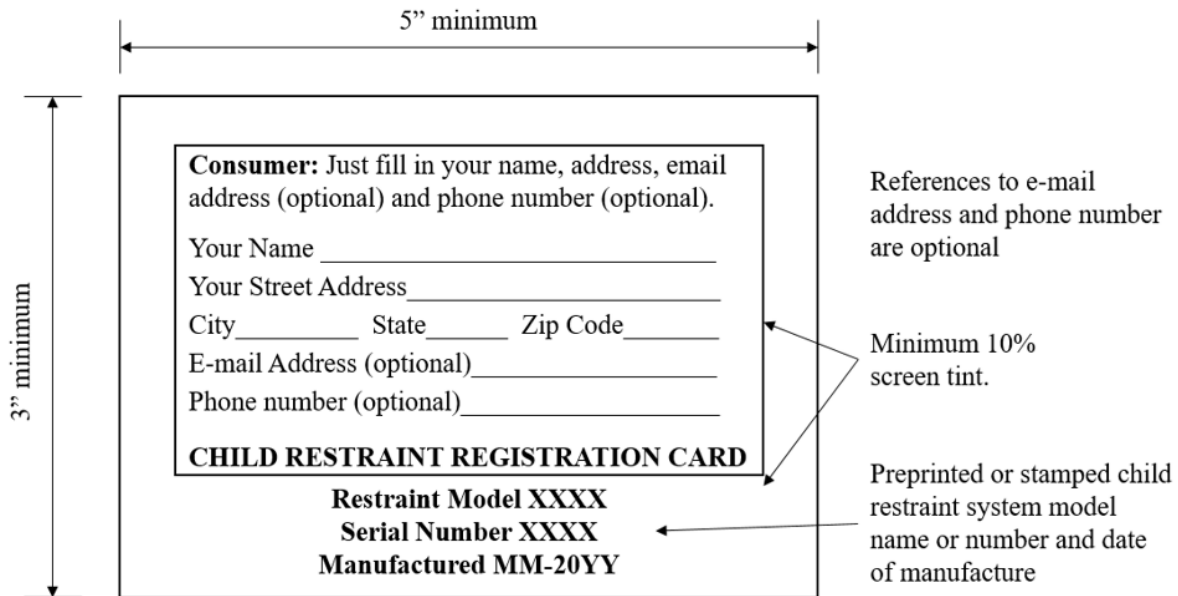

Figure 9b to § 571.213b – Registration Form for Child Restraint Systems – Address Side.

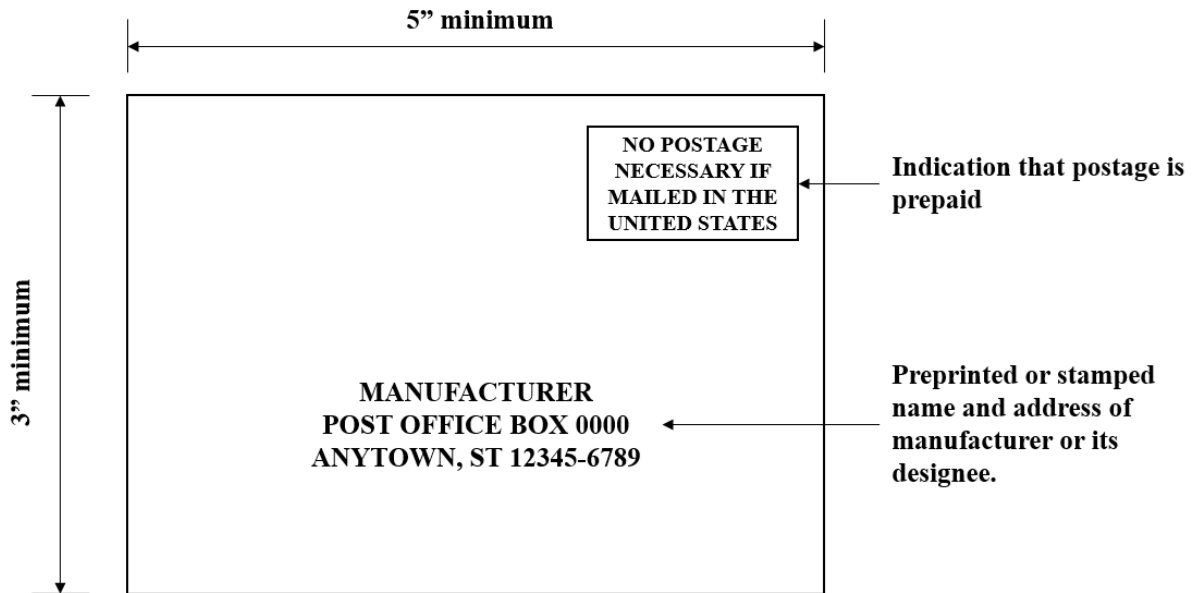
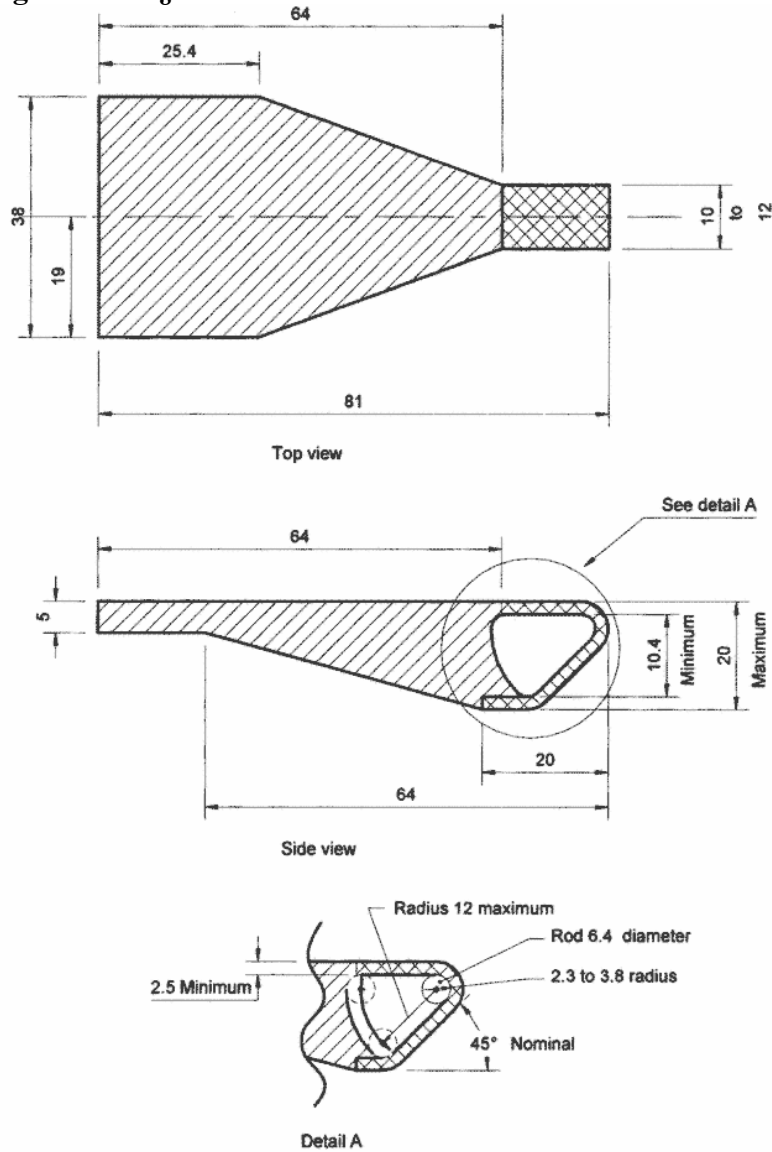

Figure 10 to § 571.213b. Label on Child Seat Where Child's Head Rests.



Label Outline, Vertical and Horizontal Line Black



Figure 11 to § 571.213b – Interface Profile of Tether Hook



LEGEND:

-  Surrounding structure (if present)
-  Area in which the tether strap hook interface profile must be wholly located.

Notes

1. Dimensions in mm, except where otherwise indicated
2. Drawing not to scale

Figure 12 to § 571.213b. Label on Harness Component That Attaches to School Bus Seat Back.

Label Outline, Vertical and Horizontal Line Black

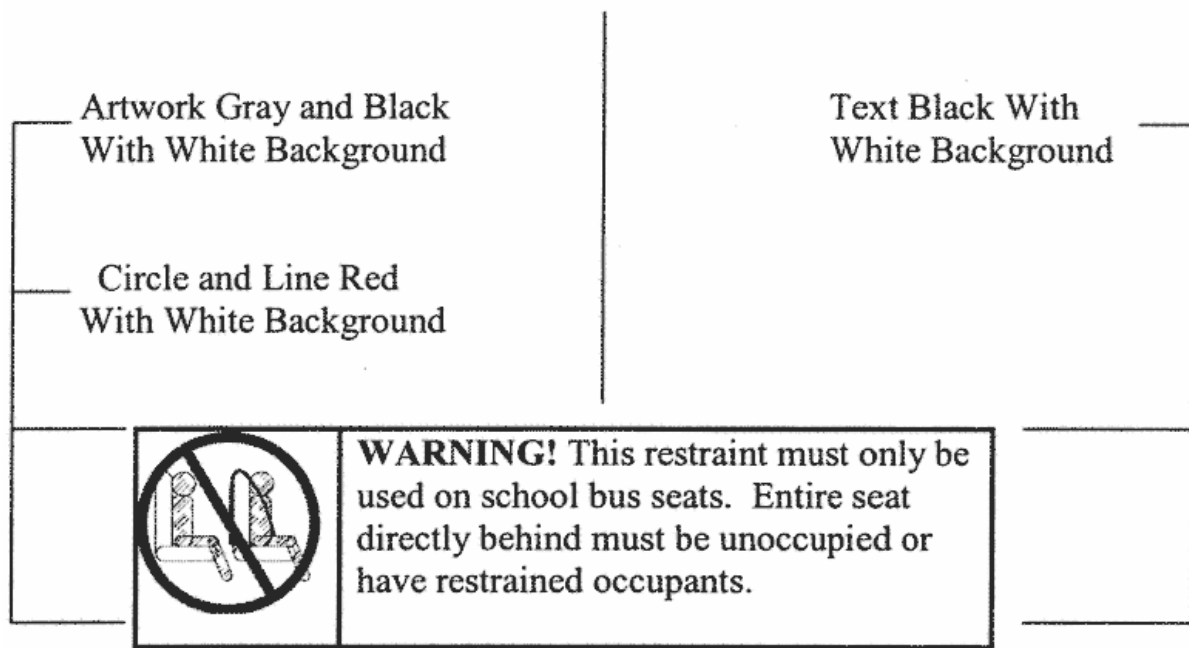

Figure 13 to § 571.213b - Lap Shield

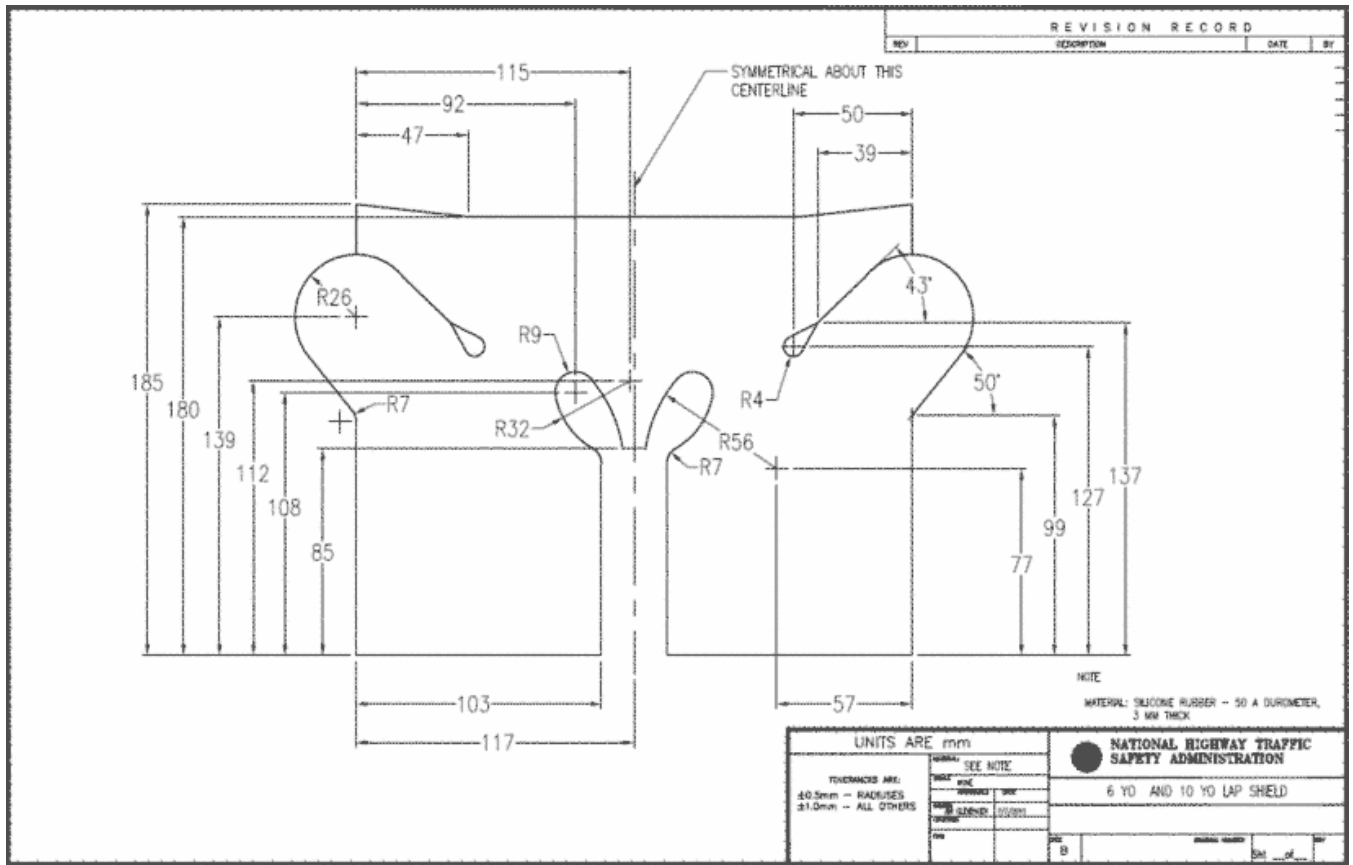

Figure 14a to § 571.213b. HIII-10C Dummy Neck Angle Setting is SP-16 Degrees

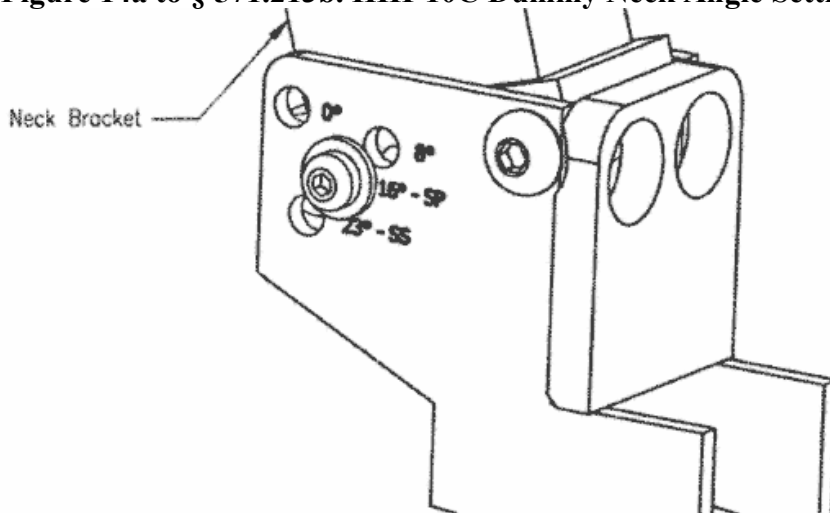
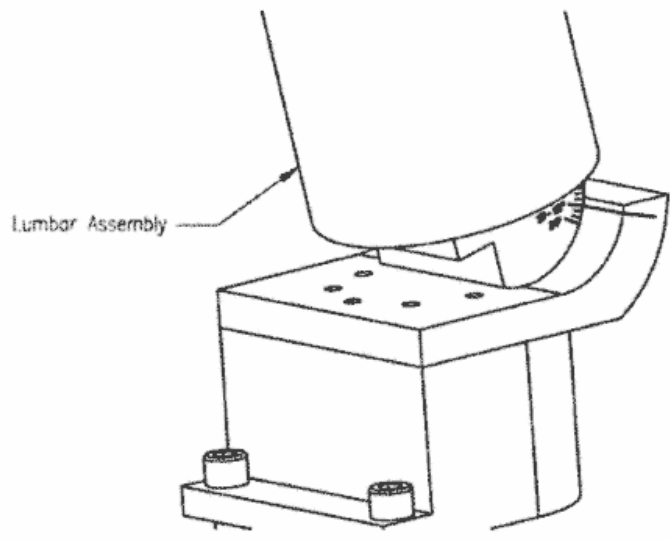

Figure 14b to § 571.213b. HIII-10C Dummy Lumbar Angle Setting is SP-12 Degrees



Issued under authority delegated in 49 CFR 1.95 and 501.8.

Ann E. Carlson
Acting Administrator

Billing Code: 4910-59-P

[FR Doc. 2023-26082 Filed: 12/4/2023 8:45 am; Publication Date: 12/5/2023]