



[6450-01-P]

DEPARTMENT OF ENERGY

10 CFR Parts 429 and 430

EERE-2019-BT-TP-0012

RIN 1904-AD86

Energy Conservation Program: Test Procedure for External Power Supplies

AGENCY: Office of Energy Efficiency and Renewable Energy, Department of Energy.

ACTION: Notice of proposed rulemaking and request for comment.

SUMMARY: The U.S. Department of Energy (“DOE”) is proposing to revise its test procedure for external power supplies (“EPS” or “EPSs”). DOE is proposing to add a definition for “commercial and industrial power supply” in its regulations to differentiate between EPSs and other non-consumer power supplies that are not subject to the test procedure. DOE also proposes to add a definition to address an adaptive EPS that conforms to the Universal Serial Bus Power Delivery (“USB-PD EPS”) specifications and revise its procedure to address their testing in a manner more representative of their actual use. Further, the proposed revisions would provide more specific instructions for testing single-voltage EPSs that have multiple output busses. Lastly, DOE proposes to reorganize the test procedure to centralize definitions, consolidate generally applicable requirements, and better delineate requirements for single-voltage, multiple-voltage, and adaptive EPSs. DOE is seeking comment from interested parties on the proposal.

DATES: *Comments:* Written comments, data, and information are requested and will be accepted no later than **[INSERT DATE 60 DAYS AFTER DATE OF PUBLICATION IN THE FEDERAL REGISTER]**. See section V, “Public Participation,” for details.

Meeting: DOE will hold a webinar on Wednesday, December 11, 2019, from 1:00 am to 4:00 pm. See section V, “Public Participation,” for webinar registration information, participant instructions, and information about the capabilities available to webinar participants. DOE will hold a public meeting on this proposed test procedure if one is requested by **[INSERT DATE 14 DAYS AFTER DATE OF PUBLICATION IN THE FEDERAL REGISTER]**. If a public meeting is requested, DOE will announce its date and location on the DOE website and via email. If held, the meeting will also be broadcast as a webinar. Information regarding webinar registration, participant instructions, and information about the capabilities available to webinar participants will be provided with the announcement should a public meeting be held. **ADDRESSES:** Interested persons are encouraged to submit comments using the Federal eRulemaking Portal at <http://www.regulations.gov>. Follow the instructions for submitting comments. Alternatively, interested persons may submit comments, identified by docket number EERE-2019-BT-TP-2012, by any of the following methods:

- 1) *Federal eRulemaking Portal:* <http://www.regulations.gov>. Follow the instructions for submitting comments.
- 2) *E-mail:* EPS2019TP0012@ee.doe.gov. Include the docket number EERE-2019-BT-TP-2012 or regulatory information number (RIN) 1904-AD86 in the subject line of the message.
- 3) *Postal Mail:* Appliance and Equipment Standards Program, U.S. Department of Energy, Building Technologies Office, Mailstop EE-5B, 1000 Independence Avenue, SW., Washington, DC, 20585-0121. Telephone: (202)

287-1445. If possible, please submit all items on a compact disc (“CD”), in which case it is not necessary to include printed copies.

- 4) *Hand Delivery/Courier*: Appliance and Equipment Standards Program, U.S. Department of Energy, Building Technologies Office, 950 L’Enfant Plaza, SW., Suite 600, Washington, DC, 20024. Telephone: (202) 287-1445. If possible, please submit all items on a CD, in which case it is not necessary to include printed copies.

No telefacsimilies (faxes) will be accepted. For detailed instructions on submitting written comments and additional information on the rulemaking process, see section V of this document.

Docket: The docket, which includes *Federal Register* notices, public meeting attendee lists and transcripts, comments, and other supporting documents/materials, is available for review at <http://www.regulations.gov>. All documents in the docket are listed in the <http://www.regulations.gov> index. However, some documents listed in the index, such as those containing information that is exempt from public disclosure, may not be publicly available.

The docket web page can be found at

<http://www.regulations.gov/docket?D=EERE-2019-BT-TP-0012>

The docket web page will contain simple instructions on how to access all documents, including public comments, in the docket. See section V for information on how to submit comments through <http://www.regulations.gov>.

FOR FURTHER INFORMATION CONTACT: Mr. Jeremy Domm, U.S.

Department of Energy, Office of Energy Efficiency and Renewable Energy, Building

Technologies Office, EE-2J, 1000 Independence Avenue, SW., Washington, DC, 20585-0121. Telephone: (202) 586-9870. E-mail *ApplianceStandardsQuestions@ee.doe.gov*.

Mr. Michael Kido, U.S. Department of Energy, Office of the General Counsel, GC-33, 1000 Independence Avenue, SW., Washington, DC, 20585-0121. Telephone: (202) 586-8145. E-mail: *Michael.Kido@hq.doe.gov*.

For further information on how to submit a comment or review other public comments and the docket contact the Appliance and Equipment Standards Program staff at (202) 287-1445 or by email: *ApplianceStandardsQuestions@ee.doe.gov*.

SUPPLEMENTARY INFORMATION:

Table of Contents

I. Authority and Background

A. Authority

B. Background

II. Synopsis of the Notice of Proposed Rulemaking

III. Discussion

A. Scope of Applicability

B. Adaptive EPSs

C. Definitions

1. Single-Voltage EPSs with Multiple Output Buses

2. Multiple-Voltage Adaptive EPSs

D. Industry Standards Incorporated by Reference

E. Other Proposed Amendments

1. Location of EPS Definitions

2. Consolidating Duplicative Test Requirements

3. Harmonizing Instructions for Single-Voltage and Multiple-Voltage EPSs

4. Unsustainable Loading Provisions

5. Correcting Table References

F. Test Procedure Costs, Harmonization, and Other Topics

1. Test Procedure Costs and Impact

2. Harmonization with Industry Standards

3. Other Test Procedure Topics

G. Compliance Date and Waivers

IV. Procedural Issues and Regulatory Review

A. Review Under Executive Order 12866

B. Review Under Executive Order 13771 and 13777

C. Review Under the Regulatory Flexibility Act

D. Review Under the Paperwork Reduction Act of 1995

- E. Review Under the National Environmental Policy Act of 1969
 - F. Review Under Executive Order 13132
 - G. Review Under Executive Order 12988
 - H. Review Under the Unfunded Mandates Reform Act of 1995
 - I. Review Under the Treasury and General Government Appropriations Act, 1999
 - J. Review Under Executive Order 12630
 - K. Review Under Treasury and General Government Appropriations Act, 2001
 - L. Review Under Executive Order 13211
 - M. Review Under Section 32 of the Federal Energy Administration Act of 1974
 - N. Description of Materials Incorporated by Reference
- V. Public Participation
- A. Participation in the Webinar
 - B.. Submission of Comments
 - C.. Issues on Which DOE Seeks Comment
- VI. Approval of the Office of the Secretary
- I. Authority and Background**

An EPS is a “covered product” for which DOE is authorized to establish and amend energy conservation standards and test procedures. (42 U.S.C. 6295(u)(1)(A)) DOE’s energy conservation standards and test procedures for EPSs are currently prescribed at Title 10 of the Code of Federal Regulations (“CFR”) sections 430.32(w) and 430.23(bb), respectively. The following sections discuss DOE’s authority to establish test procedures for EPSs and relevant background information regarding DOE’s consideration of test procedures for this product.

A. Authority

The Energy Policy and Conservation Act, as amended (“EPCA”),¹ authorizes DOE to regulate the energy efficiency of certain consumer products and types of industrial equipment. (42 U.S.C. 6291-6317) Title III, Part B² of EPCA established the Energy Conservation Program for Consumer Products Other Than Automobiles, which

¹ All references to EPCA in this document refer to the statute as amended through the America’s Water Infrastructure Act of 2018, Public Law 115-270 (October 23, 2018).

² For editorial reasons, upon codification in the U.S. Code, Part B was redesignated Part A.

sets forth provisions designed to improve energy efficiency for a variety of products and equipment. These products include EPSs, the subject of this document. (42 U.S.C. 6291(36)(A); 42 U.S.C. 6295(u))

EPCA's energy conservation program consists essentially of four parts: (1) testing, (2) labeling, (3) Federal energy conservation standards, and (4) certification and enforcement procedures. Relevant provisions of EPCA specifically include definitions (42 U.S.C. 6291), energy conservation standards (42 U.S.C. 6295), test procedures (42 U.S.C. 6293), labeling provisions (42 U.S.C. 6294), and the authority to require information and reports from manufacturers (42 U.S.C. 6296).

The Federal testing requirements consist of test procedures that manufacturers of covered products must use as the basis for: (1) certifying to DOE that their products comply with the applicable energy conservation standards adopted pursuant to EPCA (42 U.S.C. 6295(s)), and (2) making representations about the efficiency of those consumer products (42 U.S.C. 6293(c)). Similarly, DOE must use these test procedures to determine whether the products comply with relevant standards promulgated under EPCA. (42 U.S.C. 6295(s))

Federal energy efficiency requirements for covered products established under EPCA generally supersede State laws and regulations concerning energy conservation testing, labeling, and standards. (42 U.S.C. 6297) DOE may, however, grant waivers of Federal preemption for particular State laws or regulations, in accordance with the procedures and other provisions of EPCA. (42 U.S.C. 6297(d))

Under 42 U.S.C. 6293, EPCA sets forth the criteria and procedures DOE must follow when prescribing or amending test procedures for covered products. EPCA

requires that any test procedures prescribed or amended under this section be reasonably designed to produce test results which measure energy efficiency, energy use or estimated annual operating cost of a covered product during a representative average use cycle or period of use and not be unduly burdensome to conduct. (42 U.S.C. 6293(b)(3))

In addition, EPCA requires that DOE amend its test procedures for all covered products to integrate measures of standby mode and off-mode energy consumption. (42 U.S.C. 6295(gg)(2)(A)) Standby mode and off-mode energy consumption must be incorporated into the overall energy efficiency, energy consumption, or other energy descriptor for each covered product unless the current test procedures already account for and incorporate standby mode and off-mode energy consumption or such integration is technically infeasible. (42 U.S.C. 6295(gg)(2)(A)(i)) If an integrated test procedure is technically infeasible, DOE must prescribe separate standby mode and off-mode energy use test procedures for the covered product, if technically feasible. (42 U.S.C. 6295(gg)(2)(A)(ii)) Any such amendment must consider the most current versions of International Electrotechnical Commission (“IEC”) Standard 62301³ and IEC Standard 62087⁴ as applicable. (42 U.S.C. 6295(gg)(2)(A))

The Energy Policy Act of 2005 (“EPACT 2005”), Public Law 109-58 (August 8, 2005), amended EPCA by adding provisions related to EPSs. Among these provisions were a definition of EPS and a requirement that DOE prescribe “definitions and test procedures for the power use of battery chargers and external power supplies.” (42

³ IEC 62301, *Household electrical appliances—Measurement of standby power* (Edition 2.0, 2011-01).

⁴ IEC 62087, *Methods of measurement for the power consumption of audio, video, and related equipment* (Edition 3.0, 2011-04).

U.S.C. 6295(u)(1)(A)) DOE complied with this requirement by publishing a test procedure final rule to address the testing of EPSs to measure their energy efficiency and power consumption. 71 FR 71340 (December 8, 2006) (codified at 10 CFR part 430, Subpart B, Appendix Z, “Uniform Test Method for Measuring the Energy Consumption of External Power Supplies”).

The Energy Independence and Security Act of 2007 (“EISA 2007”), Public Law 110-140 (December 19, 2007) later amended EPCA by modifying the EPS-related definitions found in 42 U.S.C. 6291. While section 135(a)(3) of EPACT 2005 defined an EPS as “an external power supply circuit that is used to convert household electric current into DC current or lower-voltage AC current to operate a consumer product,” section 301 of EISA 2007 further amended this definition by creating a subset of EPSs called Class A EPSs. EISA 2007 defined this subset of products as those EPSs that, in addition to meeting several other requirements common to all EPSs, are “able to convert [line voltage AC] to only 1 AC or DC output voltage at a time” and have “nameplate output power that is less than or equal to 250 watts.” (42 U.S.C. 6291(36)(C)(i)) As part of these amendments, EISA 2007 prescribed minimum standards for these products (hereafter referred to as “Level IV” standards based on the marking provisions detailed under 10 CFR 430.32(w)(4)) and directed DOE to publish a final rule to determine whether to amend these standards.⁵ (42 U.S.C. 6295(u)(3)(A) and (D)) EISA 2007 also

⁵ The international efficiency markings on which DOE’s marking requirements are based consist of a series of Roman numerals (I-VI) and provide a global uniform system for power supply manufacturers to use that indicates compliance with a specified minimum energy performance standard.
<https://www.regulations.gov/document?D=EERE-2008-BT-STD-0005-0218>

required DOE to publish a second rule to determine whether the standards then in effect should be amended. (42 U.S.C. 6295(u)(3)(D)(ii))

EISA 2007 also amended EPCA by defining the terms “active mode,” “standby mode,” and “off-mode.” Each of these modes corresponds to the operational status of a given product – i.e., whether it is (1) plugged into AC mains and switched “on” and performing its intended function, (2) plugged in but not performing its intended function (*i.e.*, simply standing by to be operated), or (3) plugged in, but switched “off,” if a manual on-off switch is present. Additionally, EISA 2007 required DOE to amend its test procedure to ensure that standby and off-mode energy consumption are measured. It also authorized DOE to amend, by rule, the definitions for active, standby, and off-mode, as long as DOE considers the most current versions of IEC Standards 62301 and 62087. 42 U.S.C. 6295(gg)(2)(A) (incorporating EISA 2007 amendments related to standby and off-mode energy).

Following the amendments to EPCA under EISA 2007, Congress further amended EPCA to exclude EPSs used for certain security and life safety alarms and surveillance systems manufactured prior to July 1, 2017, from no-load standards. Public Law 111-360 (January 4, 2011). EPCA’s EPS provisions were again amended by the Power and Security Systems (“PASS”) Act, which extended the rulemaking deadline and effective date established under the EISA 2007 amendments from July 1, 2015, and July 1, 2017, to July 1, 2021, and July 1, 2023, respectively. Public Law 115-78 (November 2, 2017); 131 Stat. 1256, 1256; 42 U.S.C. 6295(u)(3)(D)(ii)). The PASS Act also extended the exclusion of certain security and life safety alarms and surveillance systems from no-load standards until the effective date of the final rule issued under 42 U.S.C.

6295(u)(3)(D)(ii) and allows the Secretary to treat some or all external power supplies designed to be connected to a security or life safety alarm or surveillance system as a separate product class or to further extend the exclusion. (42 U.S.C. 6295(u)(3)(E)(ii) and (iv))

Most recently, on January 12, 2018, the EPS Improvement Act of 2017, Public Law 115-115, amended EPCA to exclude the following devices from the EPS definition: power supply circuits, drivers, or devices that are designed exclusively to be connected to and power (1) light-emitting diodes providing illumination, (2) organic light-emitting diodes providing illumination, or (3) ceiling fans using direct current motors.⁶ (42 U.S.C. 6291(36)(A)(ii))

If DOE determines that a test procedure amendment is warranted, it must publish proposed test procedures and offer the public an opportunity to present oral and written comments on them. (42 U.S.C. 6293(b)(2)) EPCA also requires that, at least once every 7 years, DOE evaluate test procedures for each type of covered product, including EPSs, to determine whether amended test procedures would more accurately or fully comply with the requirements for the test procedures to not be unduly burdensome to conduct and be reasonably designed to produce test results that reflect energy efficiency, energy use, and estimated operating costs during a representative average use cycle or period of use. (42 U.S.C. 6293(b)(1)(A)) If the Secretary determines, on his own behalf or in response to a petition by any interested person, that a test procedure should be prescribed or amended, the Secretary shall promptly publish in the *Federal Register* proposed test

⁶ DOE amended its regulations to reflect the changes introduced by the PASS Act and EPS Improvement Act. 84 FR 437 (January 29, 2018).

procedures and afford interested persons an opportunity to present oral and written data, views, and arguments with respect to such procedures. The comment period on a proposed rule to amend a test procedure shall be at least 60 days and may not exceed 270 days. In prescribing or amending a test procedure, the Secretary shall take into account such information as the Secretary determines relevant to such procedure, including technological developments relating to energy use or energy efficiency of the type (or class) of covered products involved. (42 U.S.C. 6293(b)(2)). If DOE determines that test procedure revisions are not appropriate, DOE must publish its determination not to amend the test procedures. DOE is publishing this NOPR in satisfaction of the 7-year review requirement specified in EPCA. (42 U.S.C. 6293(b)(1)(A))

B. Background

DOE's existing test procedures for EPSs appear at 10 CFR part 430, Subpart B, Appendix Z, "Uniform Test Method for Measuring the Energy Consumption of External Power Supplies" ("Appendix Z"). These procedures were first established on December 8, 2006. 71 FR 71340. On March 27, 2009, pursuant to the provisions in EISA 2007, DOE published a final rule that added the terms and definitions related to EPSs to Appendix Z. 74 FR 13318. On June 1, 2011, DOE further amended Appendix Z by adding a test method for multiple-voltage EPSs. 76 FR 31750. The amendments also revised the definition of "active power" and clarified how to test an EPS that (1) has a current-limiting function, (2) can communicate with its load, or (3) combines a current-limiting function with the ability to communicate with a load. A current-limited EPS is one that can significantly lower its output voltage once an internal output current limit has been exceeded. An EPS that communicates with its load refers to an EPS's ability to

identify or otherwise exchange information with its load (*i.e.*, the end-use product to which it is connected). These revisions provided manufacturers with additional detail on how to conduct the test and determine the measured energy use for these types of EPSs.

On February 10, 2014, DOE published a final rule (“February 2014 final rule”) prescribing new standards for some non-Class A EPSs and amended standards for some Class A EPSs. 79 FR 7846. The February 2014 final rule also established new definitions for direct operation EPSs and indirect operation EPSs in 10 CFR 430.2, which distinguish between these devices based on whether the EPS is used to power a battery charger.⁷ Direct operation EPSs, regardless of whether they are Class A EPSs, are subject to more stringent standards than the statutory Level IV standard requirements. Direct operation EPSs must meet prescribed efficiency levels, based on their power output, that correspond to what are identified as Level VI standards. An EPS meeting this level of efficiency must be identified with a Level VI marking per 10 CFR 430.32(w)(4). With respect to indirect operation EPSs, the February 2014 final rule did not prescribe a specific efficiency level for these devices. Nonetheless, indirect operation EPSs imported or domestically manufactured on or after July 8, 2008, that meet the definition of a Class A EPS must meet the prescribed Level IV standards established by EISA 2007. (42 U.S.C. 6295(u)(3)(A)) Direct operation EPSs domestically

⁷ Specifically, the regulation defines a “direct operation external power supply” as “an external power supply that can operate a consumer product that is not a battery charger without the assistance of a battery.” In contrast, an “indirect operation external power supply” is one that “cannot operate a consumer product that is not a battery charger without the assistance of a battery.” 10 CFR 430.2.

manufactured or imported into the U.S. on or after February 10, 2016, must meet the Level VI standards.⁸

Following the publication of the February 2014 final rule, DOE received follow-up questions and requests for clarification regarding how to test certain EPSs. To address these issues, DOE published a test procedure final rule on August 25, 2015 (“August 2015 final rule”), which added further detail to Appendix Z. 80 FR 51424. These changes also updated references to the latest version of IEC 62301, “Household electrical appliances—Measurement of standby power,” Edition 2.0, 2011-01, and clarified DOE’s test procedure to better reflect evolving technologies.

On June 8, 2017 and June 22, 2017, the Information Technology Industry Council (“ITI”), on behalf of four petitioners – Apple, Inc. (“Apple”), Microsoft Corporation (“Microsoft”), Poin2 Lab (“Poin2”), and Hefei Bitland Information Technology Co., Ltd. (“Bitland”), filed petitions for waivers from the current DOE test procedure for EPSs under 10 CFR 430.27 for several basic models of adaptive EPSs (“USB-PD EPSs” – short for “Universal Serial Bus – Power and Data”) that meet the voltage and current provisions of the IEC’s “Universal serial bus interfaces for data and power - Part 1-2: Common components - USB Power Delivery” (“IEC 62680-1-2”) specification – which specifies the relevant performance and compatibility-related specifications for USBs but does not, like some other IEC documents, prescribe any specific testing requirements.

⁸ Generally, a covered product must comply with the relevant standard in effect as of the date the product is manufactured. For products imported into the U.S., this is the date of importation. 42 U.S.C. 6291(10) (“The term ‘manufacture’ means to manufacture, produce, assemble or import.”)

An adaptive EPS is one with an output bus⁹ that can alter its output voltage based on an established digital communication protocol with the end-use application without any user-generated action. In a notice published on July 24, 2017, DOE granted the petitions for interim waiver and specified an alternate test procedure the manufacturers were required to follow when testing and certifying the specific basic models for which the petitioners requested a waiver. 82 FR 34294. On March 16, 2018, DOE published a notice of decision and order announcing that it had granted the petitioners a waiver from the EPS test procedure for certain adaptive EPSs. The decision and order required the petitioners to test and certify these models according to the alternate test procedure presented in the decision and order. 83 FR 11738. DOE published a series of decision and order notices granting the same waiver to Huawei Technologies (83 FR 25448 (June 1, 2018)) and extending Apple's to two more basic models. (83 FR 50905 (October 10, 2018) and 83 FR 60830 (November 27, 2018)).

II. Synopsis of the Notice of Proposed Rulemaking

In this notice of proposed rulemaking (“NOPR”) DOE proposes to update Appendix Z as follows:

- 1) Adopt a definition of “commercial and industrial power supply,” that would apply specific characteristics to help distinguish these power supplies from EPSs, as defined in EPCA, which are consumer products under the statute.
- 2) Amend the definition of “external power supply” to expressly exclude any “commercial and industrial power supply.” Power supplies that meet the

⁹ An “output bus” is defined as “any of the outputs of the power supply to which loads can be connected and from which power can be drawn, as opposed to signal connections used for communication.” Section 2 of Appendix Z.

definition of “commercial and industrial power supply” would, therefore, not be subject to the EPS test procedure.

- 3) Create a definition for USB-PD EPSs and amend their testing requirements, consistent with recently issued waivers.
- 4) Provide additional direction for testing single-voltage EPSs with multiple output busses.
- 5) Provide instructions to allow any functionality that is unrelated to the external power supply circuit to be disconnected during testing as long as the disconnection does not impact the functionality of the external power supply itself.
- 6) Reorganize the test procedure to remove redundant definitions, modify the definition of “average active-mode efficiency”, centralize definitions, consolidate generally applicable requirements, and better delineate requirements for single-voltage, multiple-voltage, and adaptive EPSs.

DOE has tentatively determined that the proposed amendments would not alter the measured efficiency of EPSs, and that the proposal, if adopted, would not be unduly burdensome to conduct. DOE’s proposed actions are summarized in Table II.1 of this NOPR and addressed in detail in section III of this document. A redline markup of the current test procedure with the proposed changes is available in the rulemaking docket.

Table II.1 Summary of Changes in Proposed Test Procedure Relative to Current Test Procedure

Current DOE Test Procedure	Proposed Test Procedure	Attribution, Reason
Defines EPSs as a power supply circuit used to convert household electric current into DC current or lower-voltage AC current to operate a consumer product. 10 CFR 430.2	Would define a “commercial and industrial power supply” to delineate those power supplies that do not fall within the scope of the “external power supply” definition set out by Congress. 10 CFR 430.2	Stakeholder inquiries.
Requires adaptive EPSs that meet the IEC 62680-1-2 specification to test at 3 amps for the 100% loading condition at the lowest operating output voltage of 5 volts. 10 CFR part 430, Subpart B, Appendix Z, Sec. 4.	Would define an adaptive EPS that meets the voltage/current specifications of IEC 62680-1-2 as a “USB-PD EPS” and require that it be tested at 2 amps for the 100% loading condition at the lowest operating output voltage of 5 volts. Would also define a USB Type-C connector. 10 CFR part 430, Subpart B, Appendix Z, Sec. 3, 6(a)(1)(iii)B, 6(b)(1)(iii)B.	Adaptive EPS waivers.
Adaptive EPS instructions are currently a subsection within the single-voltage EPS testing instructions in section 4(a)(i)(E) of Appendix Z. 10 CFR part 430, Subpart B, Appendix Z, Sec. 4(a)(i)(E).	Would move instructions for non-adaptive EPSs to section 5 and add a new section 6 in Appendix Z for testing all adaptive EPSs, with two sub-sections for single-voltage and multiple-voltage adaptive EPSs. 10 CFR part 430, Subpart B, Appendix Z, Sec. 6.	Adaptive EPS waivers, stakeholder inquiries, improve readability of TP (with added waiver provisions, better delineates requirements for single-voltage, multiple-voltage, and adaptive EPSs).
Does not explicitly provide instructions for testing single-voltage EPSs with multiple output busses. 10 CFR part 430, Subpart B, Appendix Z (Generally).	Would provide explicit instructions for testing single-voltage EPSs with multiple output busses. 10 CFR part 430, Subpart B, Appendix Z, Sec. 5(a)(1)(iv).	Innovation in the marketplace and Stakeholder inquiries.
Does not provide instructions for allowing functions unrelated to the external power supply circuit to be disconnected during testing. 10 CFR part 430, Subpart B, Appendix Z, Sec. 4(h).	Would provide explicit instructions for disconnecting non-EPS functions during testing 10 CFR part 430, Subpart B, Appendix Z, Sec. 4(i).	Stakeholder inquiries.
Defines "nameplate output power" as the value on the Product's nameplate or manufacturer's documentation. 10 CFR part 430, Subpart B, Appendix Z, Sec. 2o.	Would redefine “nameplate output power” to provide an exception for USB-PD EPSs, which tests these devices at 10W. The exception would permit adaptive EPSs meeting this specification to be tested using the same 10W level. 10 CFR part 430, Subpart B, Appendix Z, Sec. 3.	Adaptive EPS waivers.

Current DOE Test Procedure	Proposed Test Procedure	Attribution, Reason
Contains redundant definitions that had been carried over from previous revisions of the test procedure but are no longer referenced. 10 CFR part 430, Subpart B, Sec. 2e., h., l., m., y.	Would remove redundant definitions that are no longer referenced.	Improve ease of reference and readability.
Numerous EPS related definitions are spread across multiple locations in 10 CFR 430.2 and Appendix Z. 10 CFR 430.2 and Subpart B, Appendix Z (Generally).	Would consolidate all EPS related definitions to Appendix Z. 10 CFR part 430, Subpart B, Appendix Z, Sec. 3.	Improve ease of reference and readability.
Defines “average active-mode efficiency” as the average of the loading conditions for which a unit can sustain output current. 10 CFR part 430, Subpart B, Appendix Z, Sec. 2f.	Would redefine “average active-mode efficiency” to explicitly state that the definition references the average of the active mode efficiencies measured at the loading conditions for which a unit can sustain output current. 10 CFR part 430, Subpart B, Appendix Z, Sec. 3.	Improve readability of TP.
Contains repetitive instructions across multiple sections on uncertainty and resolution requirements for power measurements, room air speed and temperature conditions, input voltage source, product configuration, and wire gauge requirements for leads. 10 CFR part 430, Subpart B, Appendix Z, Sec. 3(a), 3(b).	Would consolidate these requirements that are applicable to all EPSs into a single section within Appendix Z. 10 CFR part 430, Subpart B, Appendix Z, Sec. 4.	Improve readability of TP (with added waiver provisions, better delineates requirements for single-voltage, multiple-voltage, and adaptive EPSs).
Incorporates by reference the entire IEC 62301 Ed. 2.0 industry standard. 10 CFR part 430, Subpart B, Appendix Z (Generally).	Would incorporate by reference IEC 62301, add into Appendix Z particular sections from that IEC standard to use during testing, and update the shorthand notation to “IEC 62301-Z” in Appendix Z. 10 CFR part 430, Subpart B, Appendix Z, Sec. 1.	Adherence to <i>Federal Register</i> requirements.

III. Discussion

A. Scope of Applicability

EPCA defines an “external power supply” as an external power supply circuit that is used to convert household electric current into DC current or lower-voltage AC current to operate a consumer product. (42 U.S.C. 6291(36)(A)(i))

EPCA also defines a “consumer product” in relevant part as “any article . . . of a type which in operation consumes or is designed to consume energy . . . and which, to any significant extent, is distributed in commerce for personal use or consumption by individuals; without regard to whether such article of such type is in fact distributed in commerce for personal use or consumption by an individual” 42 U.S.C. 6291(1).

DOE issued guidance on December 20, 2017, that laid out the specific types of situations in which the agency would view a given power supply as falling outside of the scope of the definition of EPS in EPCA. The guidance document is available in the rulemaking docket¹⁰ and sets out the following characteristics that DOE would consider as placing a given power supply outside of the “external power supply” definition:

- 1) A power supply requiring 3-phase input power, which is incapable of operating on household current;
- 2) A DC-DC only power supply, which is incapable of operating on household current;
- 3) A power supply with a fixed, non-removable connection to an end-use device that is not a consumer product under EPCA;
- 4) A power supply whose output connector is uniquely shaped to fit only an end-use device that is not a consumer product;
- 5) A power supply that cannot be readily connected to an end-use device that is a consumer product without significant modification or customization of the power supply itself or the end-use device;

¹⁰ <https://www.regulations.gov/contentStreamer?documentId=EERE-2019-BT-TP-0012-0001&attachmentNumber=1&contentType=pdf>

- 6) A power supply packaged with an end-use device that is not a consumer product, as evidenced by either:
 - a) Such device being certified as, or declared to be in conformance with, a specific standard¹¹ applicable only to non-consumer products; or
 - b) Such device being excluded or exempted from inclusion within, or conformance with, a law, regulation, or broadly-accepted industry standard where such exclusion or exemption applies only to non-consumer products;
- 7) A power supply distributed in commerce for use with an end-use device where:
 - a) The end-use device is not a consumer product, as evidenced by either the circumstances in (6)(a) or (6)(b) of this section; and
 - b) The end-use device for which the power supply is distributed in commerce is reasonably disclosed to the public, such as by identification of the end-use device on the packaging for the power supply, documentation physically present with the power supply, or on the manufacturer's or private labeler's public website; or
- 8) A power supply that is not marketed for residential or consumer use, and that is clearly marked (or, alternatively, the packaging of the individual power

¹¹ Examples include a power supply model intended for use with an end-use device that is certified to the following standards would not meet the EPCA definition of an EPS: (1) CISPR 11 (Class A Equipment), "Industrial, scientific and medical equipment – Radio-frequency disturbance – Limits and methods of measurement"; (2) UL 1480A, "Standard for Speakers for Commercial and Professional Use"; (3) UL 813, "Standard for Commercial Audio Equipment"; and (4) UL 1727, "Standard for Commercial Electric Personal Grooming Appliances".

supply, the shipping container of multiple such power supplies, or associated documentation physically present with the power supply when distributed in commerce is clearly marked) “FOR USE WITH COMMERCIAL OR INDUSTRIAL EQUIPMENT ONLY” or “NOT FOR RESIDENTIAL OR CONSUMER USE,”¹² with the marking designed and applied so that the marking will be visible and legible during customary conditions for the item on which the marking is placed.

Consistent with the specific screening criteria laid out in the December 2017 guidance, the incorporation of these criteria into DOE’s regulations would not be the sole method for determining whether a power supply would be excluded from the definition of “external power supply.” Rather, these criteria merely identify specific and likely examples of circumstances in which DOE would not consider a power supply as meeting the definition of “external power supply” under EPCA. DOE does not intend for these criteria to preclude a person from asserting that a specific power supply falls outside of EPCA’s reach in spite of its inability to meet one or more of these eight criteria.

In order to provide manufacturers and other stakeholders additional certainty as to which power supplies would be considered to fall outside of the EPS definition, DOE proposes to use these criteria to create a new definition for a “commercial and industrial power supply” at 10 CFR part 430, and expressly exclude such products from the EPS

¹² DOE’s guidance also stated that “[n]on-material deviations from such marking . . . will not preclude satisfaction of the circumstances set forth in this paragraph” and added that “DOE may in its discretion determine that a power supply satisfies the circumstances set forth in [this paragraph] (provided all other conditions are satisfied) where such marking consists of language other than that specified in [this paragraph] but that nonetheless clearly conveys that the power supply is not marketed or intended for use with consumer products.” DOE Guidance (December 30, 2017), at 2, note 7.

definition. Specifically, DOE proposes to define “commercial and industrial power supply” as:

A power supply that is used to convert electric current into DC or lower-voltage AC current, is not distributed in commerce for use with a consumer product, and includes any of the following characteristics:

(1) A power supply that requires 3-phase input power and that is incapable of operating on household current;

(2) A DC-DC only power supply that is incapable of operating on household current;

(3) A power supply with a fixed, non-removable connection to an end-use device that is not a consumer product as defined under the Energy Policy and Conservation Act of 1975 (as amended);

(4) A power supply whose output connector is uniquely shaped to fit only an end-use device that is not a consumer product;

(5) A power supply that cannot be readily connected to an end-use device that is a consumer product without significant modification or customization of the power supply itself or the end-use device;

(6) A power supply packaged with an end-use device that is not a consumer product, as evidenced by either:

(a) Such device being certified as, or declared to be in conformance with, a specific standard applicable only to non-consumer products. For example, a power supply model intended for use with an end-use device that is certified to the following standards would not meet the EPCA definition of an EPS: (1)

CISPR 11 (Class A Equipment), “Industrial, scientific and medical equipment – Radio-frequency disturbance – Limits and methods of measurement”; (2) UL 1480A, “Standard for Speakers for Commercial and Professional Use”; (3) UL 813, “Standard for Commercial Audio Equipment”; and (4) UL 1727, “Standard for Commercial Electric Personal Grooming Appliances”; or

(b) Such device being excluded or exempted from inclusion within, or conformance with, a law, regulation, or broadly-accepted industry standard where such exclusion or exemption applies only to non-consumer products;

(7) A power supply distributed in commerce for use with an end-use device where:

(a) The end-use device is not a consumer product, as evidenced by either the circumstances in (6)(a) or (6)(b) of this section; and

(b) The end-use device for which the power supply is distributed in commerce is reasonably disclosed to the public, such as by identification of the end-use device on the packaging for the power supply, documentation physically present with the power supply, or on the manufacturer’s or private labeler’s public website; or

(8) A power supply that is not marketed for residential or consumer use, and that is clearly marked (or, alternatively, the packaging of the individual power supply, the shipping container of multiple such power supplies, or associated documentation physically present with the power supply when distributed in commerce is clearly marked) “FOR USE WITH COMMERCIAL OR INDUSTRIAL EQUIPMENT ONLY” or “NOT FOR RESIDENTIAL OR

CONSUMER USE,” with the marking designed and applied so that the marking will be visible and legible during customary conditions for the item on which the marking is placed.

As provided in the current guidance, non-material deviations from such marking cited in (8) would not preclude satisfaction of the circumstances set forth in that paragraph. In addition, DOE may in its discretion determine that a power supply satisfies the circumstances set forth in (8) (provided all other conditions are satisfied) where such marking consists of language other than that specified in (8) but that nonetheless clearly conveys that the power supply is not marketed or intended for use with consumer products.

DOE requests comment on the criteria specifying the scope of applicability of the EPS definition.

B. Adaptive EPSs

As discussed, DOE has issued test procedure waivers for several basic models of adaptive EPSs that meet the provisions of industry standard IEC 62680-1-2. (Case Nos. EPS-001, EPS-002, EPS-003, EPS-004, 2017-014, 2018-005, and 2018-010.) The IEC 62680-1-2 specification contains the voltage, current, and digital communication requirements for the adaptive Universal Serial Bus Power Delivery (“USB-PD”) system. Specifically, the USB-PD specification allows for the output voltage of a compatible EPS to adaptively change between 5 volts, 9 volts, 15 volts and 20 volts while allowing for currents up to 3 amps for the first three voltage levels and up to 5 amps at the 20 volt level upon request from a load using an established digital communication protocol. As a

result, USB-PD allows seamless interoperability across multiple consumer products with different input voltage requirements such as a mobile phone, tablet, or laptop.

As described in the notice of decision and order granting waivers to Apple, Microsoft, Poin2, and Bitland, DOE determined that applying the DOE test procedure to USB-PD EPSs would yield results that would be unrepresentative of the active-mode efficiency of those products. 83 FR 11738, 11739. Section 4(a)(i)(C) of Appendix Z requires that active-mode efficiency be measured at four loading conditions (100%, 75%, 50%, and 25%) relative to the nameplate output current of the EPS. Section 4(a)(i)(E) of Appendix Z further requires that for adaptive EPSs, the average active-mode efficiency must be measured by testing the unit twice – once at the highest achievable output voltage and once at the lowest. Thus, for an adaptive EPS with a nameplate output current of 3 amps the four active mode loading conditions are 3 amps, 2.25 amps, 1.5 amps, and 0.75 amps. The adaptive EPS would be tested using these four loading conditions at its highest achievable output voltage and its lowest achievable output voltage, which is 5 volts for USB-PD EPSs. For those USB-PD EPSs specified in the waiver orders, DOE determined that operating the EPS at the 3 amps and 5 volts test condition (resulting in a 15W output power) would not reflect the actual use in the field of USB-PD EPSs at the lowest achievable output voltage. Although the USB-PD specification requires the lowest operating point for these EPSs to be 15W at 5 volts, USB-PD EPSs operating at 5 volts generally do not exceed 10W for almost all usage conditions. When charging a product, such as a laptop, that is sold or intended to be used with a USB-PD EPS, the EPS typically charges at 5 volts only if the product has a fully discharged or fully charged battery, and in such cases, the charging current would

typically be 0.5 amps or less. At all other times when more power is needed, the EPS will typically switch to a higher voltage. If these adaptive EPSs are used to power other products such as mobile phones or tablets, the EPS will typically revert back to the lowest output voltage of 5 volts, but would generally have a charging current of no more than 2 amps (corresponding to an output power of 10W). According to data presented by manufacturers in their requests for a waiver, the bulk of consumer products that are capable of being powered by such an adaptive EPS are represented by these mobile phones, tablets and laptops. For these reasons, petitioners asserted, USB-PD EPSs are highly likely to only output power at less than 10W at an output voltage of 5 volts.

After reviewing the data provided by the petitioners, DOE concluded that when using a USB-PD EPS to charge an end-use product at the lowest voltage level of 5 volts, the product would rarely draw more than 2 amps of current at 5 volts (*i.e.*, a power draw of more than 10W). Nonetheless, for a USB-PD EPS with a nameplate output current of 3 amps, the current DOE test procedure would require that the EPS's efficiency be measured at a current of 3 amps at the lowest voltage condition of 5 volts (*i.e.*, a power draw of 15W). As a result, the efficiency of that EPS, when evaluated at that higher power draw (15W v. 10W), would result in a measurement that is unrepresentative of the actual energy consumption characteristics of the USB-PD EPS being tested. 83 FR 11738, 11739.

For USB-PD EPSs, DOE prescribed an alternate test procedure to measure their energy efficiency. Specifically, USB-PD EPSs covered by the referenced waivers must be tested such that when testing at the lowest achievable output voltage (*i.e.*, 5 volts), the output current shall be 2 amps (corresponding to an output power of 10W) at the 100%

loading condition. The 75%, 50%, and 25% loading conditions are scaled accordingly under this alternate procedure (*i.e.*, 1.5 amps, 1 amp, and 0.5 amps, respectively). When tested in this manner, the resulting power draws are 10W, 7.5W, 5W, and 2.5W; this is in contrast to the existing test procedure at Appendix Z, which would require power draws of 15W, 11.25W, 7.5W, and 3.75W, respectively. 83 FR 11738, 11739-11740. The average active mode efficiency equals the average of the efficiencies when tested at each of the four loading conditions. In addition, for such EPSs, the alternate procedure prescribes that the nameplate output power at the lowest output voltage shall be considered to be 10W at each USB-PD port, such that the appropriate energy conservation standards would apply. *Id.*

DOE notes that with any waiver it grants, it must also, as soon as practicable, publish a NOPR in the Federal Register to amend its regulations to eliminate any need for the continuation of such waiver followed by the publication of a final rule. 10 CFR 430.27(l) Accordingly, DOE is reviewing the issues presented in the waivers granted to Apple, Microsoft, Poin2, Bitland, and Huawei and proposing to adopt the alternate test procedure specified in those waivers when testing USB-PD EPSs. If DOE publishes a final rule that amends the test procedure to address the issues presented in these waivers, the waivers will automatically terminate on the date on which use of that test procedure is required to demonstrate compliance. 10 CFR 430.27(h)(2)

When DOE finalized the current testing requirements for adaptive EPSs in the August 2015 final rule, the IEC 62680-1-2 standard had not yet been published.¹³ As DOE explained in the August 2015 final rule, adaptive EPSs are unique among EPSs

¹³ The first version of IEC 62680-1-2 was published in November 2016.

because of their ability to operate at one power level when communicating with certain consumer products but an inability to reach a similar operating point when used with other consumer products lacking the ability to communicate. 80 FR 51424, 51432. The EPS test procedure was designed to capture the efficiencies at the various output conditions in which an adaptive EPS would operate. This is achieved by conducting the test twice at each loading condition—once at the highest achievable output voltage that is utilized while communicating with a load, and once at the lowest achievable output voltage utilized during load communication. Due to the nature of EPS design, the points in between the highest and lowest output voltage would be no less efficient than either extreme. *Id.*

Since publishing the August 2015 final rule, DOE has reviewed existing and legacy USB specifications as well as existing products with USB output ports. While the legacy USB specifications (USB 2.0, USBBC 1.2) published prior to March 2016 limit the current output to 1.5 amps, several consumer devices on the market today operate with USB EPSs with nameplate output currents of 2.0 amps or 2.4 amps at nameplate output voltages of 5 volts. These EPSs, operating at power ratings higher than those specified in legacy USB specifications, were the industry's response to consumer demand for faster charging in mobile devices and greater utility of USB chargers at a rate that outpaced the original USB specifications.

Based on this review of USB products on the market and the recent waiver requests from industry for USB-PD EPSs, limiting the current draw at the 100% loading condition to 2 amps when testing at the lowest nameplate output voltage would ensure

that testing is performed in a manner that is representative of typical use. 42 U.S.C. 6293(b)(3)

Accordingly, DOE is proposing to add definitions for USB-PD EPSs and the physical USB Type-C connector that supports it in section 3 of Appendix Z to reflect the voltage and current requirements specified in IEC 62680-1-2. In particular, DOE proposes to define the term USB Power Delivery (“USB-PD”) EPS to mean “an adaptive EPS that utilizes a USB Type-C output port and uses a digital protocol to communicate between the EPS and the end-user product to automatically switch between an output voltage of 5 volts and one or more of the following voltages: 9 volts, 15 volts, or 20 volts. The USB-PD output bus must be capable of delivering 3 amps at an output voltage of 5 volts, and the voltages and currents must not exceed any of the following values for the supported voltages: 3 amps at 9 volts; 3 amps at 15 volts, and; 5 amps at 20 volts”. DOE additionally proposes to define the term USB Type-C as “the reversible 24-pin physical USB connector system that supports USB-PD and allows for the transmission of data and power between compatible USB products.”

Alternatively, DOE is also considering referencing IEC 62680-1-2 in the proposed USB-PD EPS and USB Type-C definitions. With this approach, the definitions would either reference the entire standard, or individual pertinent sections.

DOE requests comment on its proposed definitions for USB-PD EPSs, and whether it accurately captures the specifications required to distinguish a USB-PD device from other adaptive EPSs. Similarly, DOE requests comments on its proposed definition for the USB Type-C connector and whether it accurately captures the specifications required to distinguish it from other physical port designs that can support adaptive

external power supplies. DOE also requests comment on its alternate suggestion for defining a USB-PD EPS by referencing the IEC 62680-1-2 standard, either in its entirety or individual pertinent sections. For the latter, DOE seeks feedback on which individual sections of IEC 62680-1-2 would be pertinent in distinguishing a USB-PD device from other adaptive EPSs. If neither DOE's proposed definition nor the alternate suggestion is appropriate, DOE requests comment on the appropriate specification to reference as well as the reasons for it.

Additionally, DOE is proposing to require that USB-PD EPSs be tested at the lowest nameplate output voltage (*i.e.*, 5 volts as prescribed for these EPSs) at 2 amps for the 100% loading condition. The remaining loading points of 75%, 50% and 25% would be scaled down from this 2-amp maximum current value to 1.5 amps, 1 amp, and 0.5 amps, respectively. These requirements would be specified in new paragraphs 6(a)(1)(iii)(B) and 6(b)(1)(iii)(B) of Appendix Z for single-voltage and multiple-voltage adaptive EPSs, respectively. The average active-mode efficiency of any unit under test ("UUT") would still be represented as the arithmetic average of the active-mode efficiencies at the four loading conditions. The loading conditions at the highest nameplate output voltage would be unaffected by this proposal.

While the existing testing requirements for adaptive EPSs are specified in paragraph 4(a)(i)(E) in Appendix Z, DOE is proposing to remove this paragraph and add a new section 6 in Appendix Z that would specify the testing requirements for all adaptive EPSs. The proposed requirement for single-voltage adaptive EPSs that meet the IEC 62680-1-2 specification would be specified in a new paragraph 6(a)(1)(iii)(B) of

Appendix Z, and those for multiple-voltage adaptive EPSs would be specified in a new paragraph 6(b)(1)(iii)(B).

DOE requests comment on its proposed amendments for USB-PD EPS and is particularly interested in whether the 2-amp limit is appropriate to use for the maximum current at the lowest nameplate output voltage for these products.

In addition to proposing testing requirements for USB-PD EPSs, DOE is also proposing to amend the related certification requirements for these products. The current certification requirements for adaptive EPSs at 10 CFR 429.37(b)(2)(iii) require reporting the nameplate output power in W at the highest and lowest nameplate output voltages, among other reported values. Section 2 of Appendix Z defines nameplate output power as the power output as specified on the manufacturer's label on the power supply housing or, if absent from the housing, as specified in documentation provided by the manufacturer. Under the current test procedure, for a USB-PD EPS, the nameplate output power at the lowest nameplate voltage of 5 volts would be 15W. However, since DOE is proposing that these EPSs be tested at a maximum output current of 2 amps, corresponding to an output power of 10W, DOE is proposing that such EPSs would be certified at 10W as well. Accordingly, DOE is proposing to amend the definition of nameplate output power in Appendix Z to explicitly state that for USB-PD ports, nameplate output power is 10W at the 5 volt level and as specified on the manufacturer's label or documentation at the highest voltage.

For example, a USB-PD EPS that is rated at 5 volts, 3 amps at the lowest nameplate output voltage and 9 volts, 1.5 amps at the highest nameplate output voltage, would be tested at 5 volts, 2 amps (*i.e.*, 10W) at the lowest nameplate output voltage and

9 volts, 1.5 amps (*i.e.*, 13.5W) at the highest nameplate output voltage, based on the proposed amendments. Under the proposed approach, the tested device would be certified at 10W and 13.5W at the lowest and highest nameplate output powers, respectively.

DOE is also proposing corresponding amendments to the certification requirements for single-voltage adaptive EPSs in 10 CFR 429.37(b)(2)(iii). Specifically, DOE is proposing that for all USB-PD EPSs, all of the required reported values must be provided, but with the loading conditions at the lowest operating voltage scaled such that the output current at the 100%, 75%, 50% and 25% loading conditions would be set at 2 amps, 1.5 amps, 1 amp and 0.5 amps, respectively.

C. EPS Configurations

DOE's test procedure for EPSs account for the different configurations that these devices can have. Because a given EPS's configuration is tied to its capabilities, DOE's procedure attempts to address these design aspects when evaluating the energy efficiency of a given EPS. The various issues encountered by DOE regarding the testing of EPSs with different design configurations follow.

1. Single-Voltage EPSs with Multiple Output Busses

Stakeholders raised questions regarding how to load an EPS that is able to convert to only one output voltage at a time and has multiple output busses (*i.e.*, a single-voltage EPS with multiple output busses). A single-voltage EPS with multiple output busses is a single-voltage EPS and must be tested according to section 3.a of Appendix Z with measurements taken as specified in section 4.a of Appendix Z. DOE previously explained during a November 21, 2014, public meeting to discuss the EPS test procedure

(“November 2014 public meeting”) that these single-voltage EPSs are to be tested at the same loading conditions as conventional single-voltage EPSs, using multiple loads across the busses to draw the complete nameplate output current from the EPS itself. (Docket No. EERE-2014-BT-TP-0043, DOE Public Meeting Transcript, No. 9, p. 43) At the time of the November 2014 public meeting, single-voltage EPSs with multiple output busses had limited availability in the marketplace, and the more explicit direction discussed during the November 2014 public meeting was not included in the regulatory text.

DOE recognizes, however, that since the publication of the August 2015 final rule, rapid innovation has led to single-voltage EPSs with multiple output busses becoming much more prevalent on the market, making it appropriate now to include more explicit directions for these EPSs. Therefore, DOE proposes to add regulatory text providing that any EPS that outputs the same voltage across multiple output busses must be tested in a configuration such that all busses are simultaneously loaded to their maximum output at the 100% loading condition, utilizing the proportional allocation method where necessary. This proposed amendment, which would be made at paragraph 5(a)(1)(iv) of Appendix Z, would require that each output be appropriately scaled for testing the 75%, 50%, and 25% loading conditions. DOE is also proposing to apply the same approach to adaptive EPSs that have multiple output busses that are capable of outputting the same voltage simultaneously. Accordingly, DOE is proposing to include this requirement in paragraph 6(a)(1)(iv) of Appendix Z.

This approach addresses two possible scenarios when testing single-voltage EPSs with multiple output busses. First, an EPS may list one nameplate output current that corresponds to the sum of the maximum current that can be drawn from all ports. As one

example, consider an EPS with three ports, each of which can support the same maximum output current of 0.5 amps, with a total nameplate output current of 1.5 amps. Each port would be loaded to 0.5 amps at 100% load (for a total current load of 1.5 amps). Each load would then be scaled down as necessary to test at all the remaining loading conditions (*i.e.*, each port would be loaded to 0.375 amps at 75% load; 0.25 amps at 50% load; and 0.125 amps at 25% load). As another example, consider an EPS with three ports, in which one port can support a maximum current of 1 amp and the two remaining ports each supporting a maximum current of 0.5 amps – yielding a total nameplate output current of 2.0 amps for the EPS. In such a scenario, all three ports would be loaded simultaneously to 1.0/0.5/0.5 amps, respectively, at the 100% loading condition (for a total current load of 2.0 amps). Each load would then be scaled down as necessary to test all remaining loading conditions (*i.e.*, the ports would be loaded at 0.75/0.375/0.375 amps at 75% load; 0.5/0.25/0.25 amps at 50% load; and 0.25/0.125/0.125 amps at 25% load).

The second possible scenario involves a single-voltage EPS with multiple output busses for which the total nameplate output current is less than the sum of the maximum current that can be drawn from each of the individual ports. In this scenario, the load at each port would be appropriately scaled down using the proportional allocation method. For example, consider an EPS with three ports, each of which can support the same maximum output current of 0.5 amps, with a total nameplate output current of 1.2 amps. At the 100% loading condition, each port could not be loaded to 0.5 amps, because the total current (1.5 amps) would exceed the EPS's total nameplate output current of 1.2 amps. In this scenario, the load would be appropriately scaled down using the

proportional allocation method, such that each port would be loaded to 0.4 amps at 100% load (for a total current load of 1.2 amps). Each load would then be further scaled down as necessary to test at all the remaining loading conditions (*i.e.*, each port would be loaded to 0.3 amps at 75% load; 0.2 amps at 50% load; and 0.1 amps at 25% load).

The additional detail described in this section for testing single-voltage EPSs with multiple output busses is being proposed to reflect current industry practice. DOE requests comment on these proposed provisions.

2. Multiple-Voltage Adaptive EPSs

Stakeholders have also inquired about how to test adaptive EPSs that operate as multiple-voltage EPSs. The definition of multiple-voltage EPS, as well as the new proposed definition of adaptive EPS, both apply to a multiple-voltage EPS with multiple output busses in which one or more of the busses are adaptive. Currently, section 4(a)(i)(E) of Appendix Z requires testing adaptive EPSs twice – once at the highest nameplate output voltage and once at the lowest nameplate output voltage. At each output voltage, adaptive EPSs are tested at the four loading conditions specified in Table 1 of Appendix Z (100%, 75%, 50%, and 25%). Separately, section 4(b)(i)(B) of Appendix Z requires testing multiple-voltage EPSs at four loading conditions (100%, 75%, 50%, and 25%) derated according to the proportional allocation method, with all busses loaded and tested simultaneously. Taking these two testing requirements into account, adaptive EPSs that operate as multiple-voltage EPSs are required to be tested once at the highest nameplate output voltage and once at the lowest nameplate output voltage, and for each test, all available busses must be loaded and derated according to

the proportional allocation method. DOE also notes that such EPSs are subject to the multiple-voltage EPS standards.

To more explicitly address testing and certifying adaptive EPSs that operate as multiple-voltage EPSs, DOE is proposing to add new sections 6(a) and 6(b) to Appendix Z, to explicitly address single-voltage adaptive EPSs and multiple-voltage adaptive EPSs, respectively. The proposed requirements for testing both single-voltage and multiple-voltage adaptive EPSs are similar to the requirements for testing all other single-voltage and multiple-voltage EPSs, and would include the exception regarding USB-PD EPSs when testing at the lowest nameplate output voltage, as discussed previously in section III.B. DOE is also proposing to amend the certification requirements for switch-selectable and adaptive EPSs at 10 CFR 429.37(b)(2)(ii) and (b)(2)(iii) to clarify that the requirements apply to both single-voltage as well as multiple-voltage switch-selectable and adaptive EPSs, respectively.

DOE has also identified EPSs with multiple USB output ports at 5 volts and one or more adaptive outputs with a default voltage of 5 volts, but whose output voltage varies according to the demand of the product connected to that port. Under the default operating condition, the EPS operates as a single-voltage EPS because it outputs only one voltage to all available ports. However, in a different operating condition, the adaptive output may provide a higher voltage while the other outputs remain at 5 volts. In this condition, the EPS operates as a multiple-voltage EPS because it is providing more than one output voltage simultaneously. For such a product, the definition of single-voltage EPS would not apply because the product is able to convert to different output voltages at a time, whereas a single-voltage EPS is able to convert to *only* one AC or DC output

voltage at a time (emphasis added). See Section 2 of Appendix Z. Instead, the definition of multiple-voltage EPS would apply to such a product. *Id.* DOE's proposed addition of a new definition of adaptive EPS would also apply.

With these proposed amendments, an EPS that has both adaptive and non-adaptive output busses would be considered a multiple-voltage adaptive EPS and would be tested under the newly proposed section 6(b) of Appendix Z. Both the adaptive and non-adaptive ports would be tested twice – first with the adaptive port at the highest nameplate output voltage and the non-adaptive ports at their fixed voltage; and again with the adaptive port at the lowest nameplate output voltage and the non-adaptive ports remaining at their fixed voltage. At each of the two test voltages, the proportional allocation method can continue to be used to derate the loading conditions where necessary. As proposed, this testing approach for EPSs with both adaptive and non-adaptive ports would be made explicit in the newly proposed section 6(b)(1)(iii)(F) of Appendix Z. DOE does not intend for this proposal to change the existing testing requirements for this type of EPS, but rather intends for these amendments to provide additional detail and more specific instruction for this type of EPS, consistent with how such EPSs are currently tested and rated. Consequently, this amendment would not require re-testing or re-rating of any existing EPSs with both adaptive and non-adaptive ports.

DOE requests comment on all proposed updates related to adaptive EPSs that operate as multiple-voltage EPSs.

3. EPSs with Other Major Functions

DOE received questions about whether non-EPS-related functions are permitted to be disconnected during testing for products with USB ports. The existing test procedure at Appendix Z in 10 CFR 430, Subpart B specifies that EPSs must be tested in their final completed configuration. For example, the efficiency of a bare circuit board power supply (i.e. a power supply without its housing or DC output cord) may not be used to characterize the efficiency of the final product. DOE recognizes that the requirement to test an EPS in its final completed configuration may result in measuring the energy use of more than just an EPS (the covered product) where the EPS is a component of a product that serves one or more other major functions in addition to serving as an EPS. Accordingly, DOE proposes to amend the current requirement by specifying that components and circuits unrelated to the EPS functionality may be disconnected during testing as long as that disconnection does not impact the functionality of the EPS itself. For example, a surge protector with USB output ports may be tested with the surge protector circuit disconnected if it is distinct from the USB circuit and does not impact the EPS's functionality (i.e. the circuit from household AC input to the USB output). This proposed change, if adopted, would appear in section 4(i) of Appendix Z and apply to single-voltage, multiple-voltage, and adaptive EPSs.

DOE requests comment on the proposed update to the test procedure regarding the disconnecting of functions unrelated to the EPS.

D. Industry Standards Incorporated by Reference

The current test procedure for EPSs incorporates by reference the entire IEC 62301 Ed. 2.0 industry standard. However, only a few specific sections of the standard

are referenced in the test procedure. Therefore, DOE proposes to add a new section 1 -- “Incorporation by Reference” -- in Appendix Z to reference only those sections that are used in the EPS test procedure. Further, in incorporating IEC 62301 Ed. 2.0 by reference in section 1 of Appendix Z, DOE also proposes to identify this industry standard as “IEC 62301-Z” to indicate that the reference applies exclusively to Appendix Z. This is consistent with the nomenclatures used with other DOE test procedures that also incorporate by reference sections of IEC 62301 Ed. 2.0. Finally, in places where a current reference to IEC 62301 Ed. 2.0 restates the requirement from that standard, DOE proposes removing those redundant references to the standard.

DOE requests comment on its proposal to add in Appendix Z a new section 1 titled, “Incorporation by Reference,” in Appendix Z that would incorporate only those sections of IEC 62301 Ed. 2.0 that are referenced in the EPS test procedure at Appendix Z.

E. Other Proposed Amendments

DOE is proposing additional revisions throughout Appendix Z to remove no longer relevant definitions, centralize the remaining definitions, consolidate generally applicable requirements, and improve the delineation of requirements for single-voltage, multiple-voltage, and adaptive EPSs. This proposal is intended solely to improve the readability of the test procedure by presenting the procedure in an easy-to-understand format without resulting in substantive changes.

1. Removing Redundant Definitions

DOE proposes to remove certain definitions in Appendix Z that had been carried over from previous revisions of the test procedure but are no longer referenced in either

the current or the proposed test procedure. This proposal would ensure that only definitions relevant to the test procedure remain in Appendix Z. Specifically, DOE proposes to remove the definitions of “apparent power”, “instantaneous power”, “nameplate input frequency”, “nameplate input voltage”, and “true power factor”.

DOE requests comment on its proposal to remove these definitions, and whether the removal of these definitions would negatively impact manufacturers’ ability to make representations about the efficiency of their products to other agencies.

2. Location of EPS Definitions

DOE proposes to move all EPS-related terms that are currently defined in 10 CFR 430.2 to the EPS test procedure at Appendix Z. This proposal would ensure that all EPS-specific definitions are in one place and allow users of the test procedure to review these definitions at once without having to navigate between multiple areas of the CFR. Specifically, DOE proposes to move from 10 CFR 430.2 to Appendix Z the definitions of “adaptive external power supply”, “basic-voltage external power supply”, “direct operation external power supply”, “indirect operation external power supply”, and “low-voltage external power supply”. DOE is not proposing to amend the substance of these definitions.

The definition of “external power supply” will remain in 10 CFR 430.2, but DOE proposes to add a sentence to the definition directing the reader to Appendix Z for other EPS-related definitions. This will ensure that even though the EPS-related definitions are specified in the test procedure, they would apply throughout 10 CFR part 430, including 10 CFR 430.32. For the definition of “Class A external power supply”, which is

statutorily defined in EPCA, DOE proposes to add it to the EPS test procedure at Appendix Z but also retain it at 10 CFR 430.2, where it currently exists.

Additionally, DOE proposes to modify the definition of “average active-mode efficiency” in Appendix Z to explicitly state that the average active-mode efficiency is the average of the active mode efficiencies at the loading conditions for which an EPS can sustain the output current – not the average of the loading conditions. This term would be defined as “the average *of the active mode efficiencies* at the loading conditions (100%, 75%, 50%, and 25% of the unit under test’s nameplate output current) for which that unit can sustain the output current.” This proposal would not change the meaning of the definition; rather it would improve the readability of the test procedure.

3. Consolidating Duplicative Test Requirements

Section 3 of Appendix Z currently includes two subsections that specify the test apparatus and general instructions – one subsection specifies the requirements for single-voltage EPSs, and the other specifies the requirements for multiple-voltage EPSs. The requirements in these two subsections are largely the same. DOE proposes to combine these requirements and remove the separate subsections for single-voltage and multiple-voltage EPSs in order to provide a single, unified section for the test apparatus provisions and general instructions. Under this proposed change, the requirements would largely remain the same, but would appear in a single subsection that would apply to both single-voltage and multiple-voltage EPSs.

DOE also proposes consolidating the requirements regarding the required test load from sections 4(a)(i)(F) and 4(b)(i)(D) into a new subsection 4(f) of Appendix Z, since this requirement would remain the same across all EPSs. Similarly, DOE proposes

to consolidate the requirements regarding how to attach power metering equipment from sections 4(a)(i)(A) and 4(b) into a new subsection 4(g) of Appendix Z.

4. Harmonizing Instructions for Single-Voltage and Multiple-Voltage EPSs

DOE proposes amending sections 4(a) and 4(b) of Appendix Z. These sections provide testing requirements for single-voltage and multiple-voltage EPSs, respectively, and DOE's proposal would harmonize these requirements. Applying both a similar structure and common set of instructions to these sections would improve the procedure's readability and reduce the likelihood of procedural errors during testing. These proposed updates would retain the current testing requirements.

5. Unsustainable Loading Provisions

Section 4(a)(i)(C)2 of Appendix Z currently specifies for single-voltage EPSs that if the EPS cannot sustain output at one or more of the loading conditions prescribed by the procedure (*i.e.*, 25%, 50%, 75%, and 100%), then it must be tested only at the loading conditions for which it can sustain output, and the average active-mode efficiency is calculated as the average of the loading conditions for which it can sustain the output. DOE proposes to clarify this existing requirement to state that of the outputs that are sustainable, the EPS must be tested at the loading conditions that allow for the maximum output power on that bus (that is, the highest output current possible at the highest output voltage).

Further, DOE proposes to reorganize this provision of the test procedure pertaining to unsustainable loading conditions by moving the part of this instruction related to the efficiency calculation to a newly designated section 5(a)(1)(vi), which would specify the requirements for calculating the tested EPS's efficiency. DOE also

proposes to replicate the same requirements in the newly designated sections 5(b)(1)(vi), 6(a)(1)(vi), and 6(b)(1)(vi) for multiple-voltage, single-voltage adaptive, and multiple-voltage adaptive EPSs, respectively.

6. Correcting Table References

DOE proposes revising the current section 4(b)(i) of Appendix Z to correct a reference error. This section would be revised to refer to “Table 2” rather than “Table 1,” as currently referenced.

In light of the proposed restructuring of the test procedure, the proposed regulatory text presented in this document includes the entire EPS test procedure appendix language, including language that is not being changed from the existing requirements. Presenting the regulatory text in its entirety will assist stakeholders when reviewing the extent of the changes that DOE is proposing to make. DOE requests comment on all of the proposed changes related to the EPS test procedure raised in the preceding discussion in Section III.E.

F. Test Procedure Costs, Harmonization, and Other Topics

1. Test Procedure Costs and Impact

EPCA requires that test procedures proposed by DOE not be unduly burdensome to conduct. As discussed in the previous sections, DOE proposes to amend the existing test procedure for EPSs by: (1) providing additional detail reflective of its current application; (2) adding revisions to address adaptive EPSs to reflect current industry testing standards and provide more representative results; and (3) adding detail to address the distinction between different types of EPSs with multiple ports. This document also proposes minor amendments to consolidate duplicative testing requirements, harmonized

testing requirements for single-voltage and multiple-voltage EPSs, and improved organization of the test provisions regarding unsustainable loading conditions. DOE has tentatively determined that these proposed amendments would not be unduly burdensome for manufacturers to conduct.

DOE's analysis of this proposal indicates that, if finalized, it would not result in any additional costs or cost savings to manufacturers.

Further discussion of the cost impacts of the proposed test procedure amendments are presented in the following paragraphs.

If adopted, the proposed amendments would provide updates and supplemental details for how to conduct the test procedure and would neither increase complexity to test conditions/setup nor add new test steps. For example, the proposal would add references to specific sections of industry standards to provide precise direction to test technicians when conducting the test procedure. Consistent with industry inquiries and requests, DOE is proposing to revise or add definitions and test conditions to provide more specific direction. Further, DOE reorganized content and aligned terminology among relevant sections of the CFR to improve readability and provide clarity in the specifications referred to throughout the sampling requirements, test procedure, and applicable energy conservation standards. DOE does not anticipate that the amendments proposed in this NOPR would impact test costs.

DOE is also proposing to codify characteristics that can be used to differentiate between EPSs used to operate consumer products and power supplies that are used to operate non-consumer products (*i.e.*, industrial/commercial equipment), the latter of which are not subject to the test procedure. These proposed updates clarify which power

supplies are excluded as non-consumer EPSs and would not fall within the scope of the test procedure. As such, these amendments, if made final, would not affect the testing burden faced by manufacturers when evaluating the efficiency of those products covered by the procedure.

With respect to USB-PD EPSs, DOE is proposing amendments based on the previously-mentioned petition for waiver filed by ITI on behalf of petitioners Apple, Microsoft, Poin2, and Bitland. In conjunction with this proposed change, because EPSs are required to be tested at their nameplate output power, DOE is proposing to amend the definition of “nameplate output power” to provide an exception for USB-PD EPSs, which would be tested at 10W at the lowest voltage instead of at their maximum capability at that voltage. The proposal would change the operating point at which testing is performed, but would not require any additional tests than are already required under the current test procedure. Hence, manufacturers would not incur any additional costs compared to the existing test procedure. Further, DOE is proposing to add further specification to the testing requirements for adaptive EPSs that also operate as multiple-voltage EPSs. The testing requirements for such EPSs would not change under this proposal. Accordingly, DOE does not anticipate that its proposal will result in any additional costs compared to the current test procedure.

DOE is also proposing to provide more explicit instructions for testing single-voltage EPSs that have multiple output busses. For such EPSs, DOE’s proposal would not change the existing testing requirements. Instead, the proposal would improve the readability of the existing requirements. If finalized, these proposed amendments would provide supplemental detail but would not require manufacturers to test EPSs any

differently and would result in no change in the associated testing cost compared to the current test procedure.

DOE also proposes to reorganize the test procedure to centralize the EPS-related definitions and relevant, general requirements, and better delineate the specific requirements for single-voltage, multiple-voltage, and adaptive EPSs. This proposed reorganization, like the amendments described earlier, are intended to improve the readability of the test procedure while avoiding any substantive changes; therefore, there would be no change in the associated testing cost compared to the current test procedure.

DOE has preliminarily concluded that the proposed amendments, if made final, would not impact the scope of the test procedure (*i.e.*, the proposal would not require manufacturers to test EPSs that are not already required to be tested) and would not alter the measured energy efficiency of EPSs under either the current test procedure or alternate test procedure required under currently active test procedure waivers. For adaptive EPSs that meet the IEC 62680-1-2 specification, the proposed approach is the same one required under the granted waivers. See 83 FR 11738 (initial Decision & Order on joint waiver request from Apple, et al.), 83 FR 25448 (Decision & Order on waiver request Huawei), 83 FR 50905 (first waiver extension for Apple), and 83 FR 60830 (second waiver extension for Apple). DOE has received no other petitions for waiver regarding adaptive EPSs that meet the IEC 62680-1-2 specification. Accordingly, on the basis of currently available data, DOE has preliminarily concluded that the proposed amendments would not alter the measured energy efficiency for such adaptive EPSs. Manufacturers would be able to continue to rely on data generated under the current test procedure, including any alternate test procedure permitted by DOE under a

manufacturer-specific decision and order, should any of the proposed amendments be finalized.

DOE requests comment on its understanding of the impact of the proposals presented in this document in relation to the test burden and costs of the current test procedure.

2. Harmonization with Industry Standards

Appendix Z of 10 CFR part 430, subpart B incorporates by reference certain provisions of IEC 62301 Ed. 2.0. These provisions contain specifications for testing equipment and methods for measuring power consumption. DOE proposes to specify in section 1 of Appendix Z the relevant sections of IEC 62301 Ed. 2.0 that are referenced in Appendix Z. DOE requests comments on the benefits and burdens of the proposed updates to the industry standard referenced in the test procedure for EPSs.

DOE seeks comment on the degree to which the DOE test procedure should consider, and be harmonized further with, the most recent relevant industry standards for EPSs and whether there are any changes to the Federal test method that would provide additional benefits to the public. DOE also requests comment on the benefits and burdens of adopting any industry/voluntary consensus-based or other appropriate test procedure, without modification.

3. Other Test Procedure Topics

In addition to the issues identified earlier, DOE welcomes comment on any other aspect of the existing test procedure for EPSs not already addressed by the specific areas identified in this document. DOE particularly seeks information that would improve the ability of the test procedure to measure the energy efficiency/use of an EPS during a

representative average use cycle or period of use. Comments regarding repeatability and reproducibility are also welcome.

DOE also requests information that would help DOE create procedures that would limit manufacturer test burden through streamlining or simplifying testing requirements. In particular, DOE notes that under Executive Order 13771, “Reducing Regulation and Controlling Regulatory Costs,” Executive Branch agencies such as DOE must manage the costs associated with the imposition of expenditures required to comply with Federal regulations. 82 FR 9339 (February 3, 2017). Consistent with that Executive Order, DOE encourages the public to provide input on measures DOE could take to lower the cost of its regulations applicable to EPSs consistent with the requirements of EPCA.

G. Compliance Date and Waivers

EPCA prescribes that all representations of energy efficiency and energy use, including those made on marketing materials and product labels, must be made in accordance with an amended test procedure, beginning 180 days after publication of such a test procedure final rule in the *Federal Register*. (42 U.S.C. 6293(c)(2)) If DOE were to publish an amended test procedure EPCA provides an allowance for individual manufacturers to petition DOE for an extension of the 180-day period if the manufacturer may experience undue hardship in meeting the deadline. (42 U.S.C. 6293(c)(3)) To receive such an extension, petitions must be filed with DOE no later than 60 days before the end of the 180-day period and must detail how the manufacturer will experience undue hardship. (*Id.*)

Should DOE amend the test procedure to address the issues presented in a waiver, the waiver would automatically terminate on the date on which use of that test procedure

is required to demonstrate compliance. 10 CFR 430.27(h)(2). Recipients of any such waivers would be required to test those products that were subject to the waiver according to the amended test procedure as of the effective date of the amended test procedure. Some of the amendments proposed in this document would pertain to issues addressed by the waivers granted to Apple, Microsoft, Poin2, Bitland, and Huawei for testing USB-PD EPSs (Case Nos. EPS-001, EPS-002, EPS-003, and EPS-004).**Error!**

Bookmark not defined.

IV. Procedural Issues and Regulatory Review

A. Review Under Executive Order 12866

The Office of Management and Budget (“OMB”) has determined that test procedure rulemakings do not constitute “significant regulatory actions” under section 3(f) of Executive Order 12866, Regulatory Planning and Review, 58 FR 51735 (October 4, 1993). Accordingly, this action was not subject to review under the Executive Order by the Office of Information and Regulatory Affairs (“OIRA”) in OMB.

B. Review Under Executive Orders 13771 and 13777

On January 30, 2017, the President issued Executive Order (“E.O.”) 13771, “Reducing Regulation and Controlling Regulatory Costs.” E.O. 13771 stated the policy of the executive branch is to be prudent and financially responsible in the expenditure of funds, from both public and private sources. E.O. 13771 stated it is essential to manage the costs associated with the governmental imposition of private expenditures required to comply with Federal regulations.

Additionally, on February 24, 2017, the President issued E.O. 13777, “Enforcing the Regulatory Reform Agenda.” E.O. 13777 required the head of each agency to designate an agency official as its Regulatory Reform Officer (“RRO”). Each RRO oversees the implementation of regulatory reform initiatives and policies to ensure that agencies effectively carry out regulatory reforms, consistent with applicable law. Further, E.O. 13777 requires the establishment of a regulatory task force at each agency. The regulatory task force is required to make recommendations to the agency head regarding the repeal, replacement, or modification of existing regulations, consistent with applicable law. At a minimum, each regulatory reform task force must attempt to identify regulations that:

- (i) Eliminate jobs, or inhibit job creation;
- (ii) Are outdated, unnecessary, or ineffective;
- (iii) Impose costs that exceed benefits;
- (iv) Create a serious inconsistency or otherwise interfere with regulatory reform initiatives and policies;
- (v) Are inconsistent with the requirements of the Information Quality Act, or the guidance issued pursuant to that Act, in particular those regulations that rely in whole or in part on data, information, or methods that are not publicly available or that are insufficiently transparent to meet the standard for reproducibility; or
- (vi) Derive from or implement Executive Orders or other Presidential directives that have been subsequently rescinded or substantially modified.

DOE initially concludes that this rulemaking is consistent with the directives set forth in these executive orders. As described above, DOE has preliminarily determined

that the proposed rule would not yield any costs or cost savings. Therefore, if finalized as proposed, this rule is expected to be an E.O. 13771 other action.

C. Review Under the Regulatory Flexibility Act

The Regulatory Flexibility Act (5 U.S.C. 601 et seq.) requires preparation of an initial regulatory flexibility analysis (“IRFA”) for any rule that by law must be proposed for public comment, unless the agency certifies that the rule, if promulgated, will not have a significant economic impact on a substantial number of small entities. A regulatory flexibility analysis examines the impact of the rule on small entities and considers alternative ways of reducing negative effects. As required by Executive Order 13272, “Proper Consideration of Small Entities in Agency Rulemaking,” 67 FR 53461 (August 16, 2002), DOE published procedures and policies on February 19, 2003 to ensure that the potential impacts of its rules on small entities are properly considered during the DOE rulemaking process. 68 FR 7990. DOE has made its procedures and policies available on the Office of the General Counsel’s website:

<http://energy.gov/gc/office-general-counsel>.

DOE reviewed this test procedure NOPR pursuant to the Regulatory Flexibility Act and the procedures and policies previously discussed. DOE has concluded that this rule would not have a significant impact on a substantial number of small entities. The factual basis for this certification is set forth below. DOE will consider any comments on the certification in determining whether to adopt the proposed amendments to the test procedure contained in this document.

For manufacturers of EPSs, the Small Business Administration (“SBA”) has set a size threshold, which defines those entities classified as “small businesses” for the

purposes of the statute. DOE used the SBA's small business size standards to determine whether any small entities would be subject to the requirements of the rule. 13 CFR part 121. The size standards are listed by North American Industry Classification System (“NAICS”) code and industry description and are available at <https://www.sba.gov/document/support--table-size-standards>. EPS manufacturing is classified under NAICS 335999, “All Other Miscellaneous Electrical Equipment and Component Manufacturing.” The SBA sets a threshold of 500 employees or less for an entity to be considered as a small business in this category.

DOE consulted its CCMS database to determine the total number of original device manufacturers (“ODMs”) with manufacturing facilities located in the United States that meet the SBA’s definition of a “small business.” Due to the wide variety of applications that use EPSs, there were numerous EPS manufacturers listed in the CCMS database. However, the vast majority of EPS manufacturers are foreign companies. Of the few domestic companies listed, all of these companies exceed the size threshold defined by SBA and manufactured their EPSs abroad. Therefore, as in the 2015 test procedure final rule, DOE has determined that there are no small businesses that manufacture EPSs in the United States.

Therefore, DOE concludes that the impacts of the proposed test procedure amendments proposed in this NOPR would not have a “significant economic impact on a substantial number of small entities,” and that the preparation of an IRFA is not warranted. DOE will transmit the certification and supporting statement of factual basis to the Chief Counsel for Advocacy of the Small Business Administration for review under 5 U.S.C. 605(b).

DOE requests comment on its determination that there are no small EPS ODMs with manufacturing facilities located in the U.S.

D. Review Under the Paperwork Reduction Act of 1995

Manufacturers of EPSs must certify to DOE that their products comply with any applicable energy conservation standards. To certify compliance, manufacturers must first obtain test data for their products according to the DOE test procedures, including any amendments adopted for those test procedures. DOE has established regulations for the certification and recordkeeping requirements for all covered consumer products and commercial equipment, including EPSs. (10 CFR part 429, subpart B.) The collection-of-information requirement for the certification and recordkeeping is subject to review and approval by OMB under the Paperwork Reduction Act (“PRA”). This requirement has been approved by OMB under OMB control number 1910-1400. Public reporting burden for the certification is estimated to average 35 hours per response, including the time for reviewing instructions, searching existing data sources, gathering and maintaining the data needed, and completing and reviewing the collection of information.

Notwithstanding any other provision of the law, no person is required to respond to, nor shall any person be subject to a penalty for failure to comply with, a collection of information subject to the requirements of the PRA, unless that collection of information displays a currently valid OMB Control Number.

E. Review Under the National Environmental Policy Act of 1969

In this proposed rule, DOE proposes test procedure amendments that it expects will be used to develop and implement future energy conservation standards for external power supplies. DOE has determined that this proposed rule falls into a class of actions

that are categorically excluded from review under the National Environmental Policy Act of 1969 (42 U.S.C. 4321 et seq.) and DOE's implementing regulations at 10 CFR part 1021. Specifically, DOE has determined that adopting test procedures for measuring energy efficiency of consumer products and industrial equipment is consistent with activities identified in 10 CFR Part 1021, Appendix A to Subpart D, A5 and A6. Accordingly, neither an environmental assessment nor an environmental impact statement is required.

F. Review Under Executive Order 13132

Executive Order 13132, "Federalism," 64 FR 43255 (August 10, 1999), imposes certain requirements on agencies formulating and implementing policies or regulations that preempt State law or that have Federalism implications. The Executive Order requires agencies to examine the constitutional and statutory authority supporting any action that would limit the policymaking discretion of the States and to carefully assess the necessity for such actions. The Executive Order also requires agencies to have an accountable process to ensure meaningful and timely input by State and local officials in the development of regulatory policies that have Federalism implications. On March 14, 2000, DOE published a statement of policy describing the intergovernmental consultation process it will follow in the development of such regulations. 65 FR 13735. DOE has examined this proposed rule and has determined that it would not have a substantial direct effect on the States, on the relationship between the national government and the States, or on the distribution of power and responsibilities among the various levels of government. EPCA governs and prescribes Federal preemption of State regulations as to energy conservation for the products that are the subject of this proposed rule. States can

petition DOE for exemption from such preemption to the extent, and based on criteria, set forth in EPCA. (42 U.S.C. 6297(d)) No further action is required by Executive Order 13132.

G. Review Under the Unfunded Mandates Reform Act of 1995

Title II of the Unfunded Mandates Reform Act of 1995 (“UMRA”) requires each Federal agency to assess the effects of Federal regulatory actions on State, local, and Tribal governments and the private sector. Pub. L. 104-4, sec. 201 (codified at 2 U.S.C. 1531). For a proposed regulatory action likely to result in a rule that may cause the expenditure by State, local, and Tribal governments, in the aggregate, or by the private sector of \$100 million or more in any one year (adjusted annually for inflation), section 202 of UMRA requires a Federal agency to publish a written statement that estimates the resulting costs, benefits, and other effects on the national economy. (2 U.S.C. 1532(a), (b)) The UMRA also requires a Federal agency to develop an effective process to permit timely input by elected officers of State, local, and Tribal governments on a proposed “significant intergovernmental mandate,” and requires an agency plan for giving notice and opportunity for timely input to potentially affected small governments before establishing any requirements that might significantly or uniquely affect small governments. On March 18, 1997, DOE published a statement of policy on its process for intergovernmental consultation under UMRA. 62 FR 12820; also available at <http://energy.gov/gc/office-general-counsel>. DOE examined this proposed rule according to UMRA and its statement of policy and determined that the rule contains neither an intergovernmental mandate, nor a mandate that may result in the expenditure of \$100 million or more in any year, so these requirements do not apply.

H. Review Under the Treasury and General Government Appropriations Act, 1999

Section 654 of the Treasury and General Government Appropriations Act, 1999 (Pub. L. 105-277) requires Federal agencies to issue a Family Policymaking Assessment for any rule that may affect family well-being. This proposed rule would not have any impact on the autonomy or integrity of the family as an institution. Accordingly, DOE has concluded that it is not necessary to prepare a Family Policymaking Assessment.

I. Review Under Executive Order 12630

DOE has determined, under Executive Order 12630, “Governmental Actions and Interference with Constitutionally Protected Property Rights” 53 FR 8859 (March 18, 1988), that this proposed regulation would not result in any takings that might require compensation under the Fifth Amendment to the U.S. Constitution.

J. Review Under Executive Order 12988

Regarding the review of existing regulations and the promulgation of new regulations, section 3(a) of Executive Order 12988, “Civil Justice Reform,” 61 FR 4729 (February 7, 1996), imposes on Federal agencies the general duty to adhere to the following requirements: (1) eliminate drafting errors and ambiguity; (2) write regulations to minimize litigation; (3) provide a clear legal standard for affected conduct rather than a general standard; and (4) promote simplification and burden reduction. Section 3(b) of Executive Order 12988 specifically requires that Executive agencies make every reasonable effort to ensure that the regulation: (1) clearly specifies the preemptive effect, if any; (2) clearly specifies any effect on existing Federal law or regulation; (3) provides a clear legal standard for affected conduct while promoting simplification and burden reduction; (4) specifies the retroactive effect, if any; (5) adequately defines key terms;

and (6) addresses other important issues affecting clarity and general draftsmanship under any guidelines issued by the Attorney General. Section 3(c) of Executive Order 12988 requires Executive agencies to review regulations in light of applicable standards in sections 3(a) and 3(b) to determine whether they are met or it is unreasonable to meet one or more of them. DOE has completed the required review and determined that, to the extent permitted by law, the proposed rule meets the relevant standards of Executive Order 12988.

K. Review Under Treasury and General Government Appropriations Act, 2001

Section 515 of the Treasury and General Government Appropriations Act, 2001 (44 U.S.C. 3516 note) provides for agencies to review most disseminations of information to the public under guidelines established by each agency pursuant to general guidelines issued by OMB. OMB's guidelines were published at 67 FR 8452 (February 22, 2002), and DOE's guidelines were published at 67 FR 62446 (October 7, 2002). DOE has reviewed this proposed rule under the OMB and DOE guidelines and has concluded that it is consistent with applicable policies in those guidelines.

L. Review Under Executive Order 13211

Executive Order 13211, "Actions Concerning Regulations That Significantly Affect Energy Supply, Distribution, or Use," 66 FR 28355 (May 22, 2001), requires Federal agencies to prepare and submit to OMB, a Statement of Energy Effects for any proposed significant energy action. A "significant energy action" is defined as any action by an agency that promulgated or is expected to lead to promulgation of a final rule, and that: (1) is a significant regulatory action under Executive Order 12866, or any successor order; and (2) is likely to have a significant adverse effect on the supply, distribution, or

use of energy; or (3) is designated by the Administrator of OIRA as a significant energy action. For any proposed significant energy action, the agency must give a detailed statement of any adverse effects on energy supply, distribution, or use should the proposal be implemented, and of reasonable alternatives to the action and their expected benefits on energy supply, distribution, and use.

The proposed regulatory action to amend the test procedure for measuring the energy efficiency of EPSs is not a significant regulatory action under Executive Order 12866. Moreover, it would not have a significant adverse effect on the supply, distribution, or use of energy, nor has it been designated as a significant energy action by the Administrator of OIRA. Therefore, it is not a significant energy action, and, accordingly, DOE has not prepared a Statement of Energy Effects.

M. Review Under Section 32 of the Federal Energy Administration Act of 1974

Under section 301 of the Department of Energy Organization Act (Public Law 95–91; 42 U.S.C. 7101), DOE must comply with section 32 of the Federal Energy Administration Act of 1974, as amended by the Federal Energy Administration Authorization Act of 1977. (15 U.S.C. 788; “FEAA”) Section 32 essentially provides in relevant part that, where a proposed rule authorizes or requires use of commercial standards, the notice of proposed rulemaking must inform the public of the use and background of such standards. In addition, section 32(c) requires DOE to consult with the Attorney General and the Chairman of the Federal Trade Commission (“FTC”) concerning the impact of the commercial or industry standards on competition.

The proposed modifications to the test procedure for EPSs do not incorporate any new industry standards.

N. Description of Materials Incorporated by Reference

In this NOPR, DOE proposes to maintain the current incorporation by reference of IEC 62301 Ed. 2.0 in 10 CFR 430.3, and create a new section 1 in Appendix Z, titled “incorporation by reference”, to enumerate the specific provisions of the standard that are applicable to the EPS test procedure in Appendix Z. While incorporating IEC 62301 Ed. 2.0 by reference in section 1 of Appendix Z, DOE proposes to identify it as “IEC 62301-Z” to indicate the provisions of IEC 62301 that are applicable to Appendix Z. This is consistent with the nomenclature used with other DOE test procedures that also incorporate by reference sections of IEC 62301 Ed. 2.0. Specifically, section 1 of Appendix Z would limit use of the material incorporated by reference to the following sections of the IEC 62301:

- (1) IEC 62301, “Household electrical appliances – Measurement of standby power,” Edition 2.0, 2011-01:
 - Section 4.4.1, “Power measurement uncertainty”;
 - Section 5.3.3, “Average reading method”;
 - Annex B, “Notes on the measurement of low power modes”; and
 - Annex D, “Determination of uncertainty of measurement”.

IEC 62301 is an industry-accepted standard for measuring the standby power of household electrical appliances. This standard is reasonably available and can be obtained from the American National Standards Institute at the following addresses:

American National Standards Institute, 25 W. 43rd Street, 4th Floor, New York, NY 10036, (212) 642-4936, or by visiting <http://webstore.ansi.org>.

V. Public Participation

A. Participation in the Webinar

The time and date of the webinar are listed in the **DATES** section at the beginning of this document. If no participants register for the webinar then it will be cancelled.

Webinar registration information, participant instructions, and information about the capabilities available to webinar participants will be published on DOE's website:

<https://www.energy.gov/eere/buildings/public-meetings-and-comment-deadlines>.

Participants are responsible for ensuring their systems are compatible with the webinar software.

Additionally, you may request an in-person meeting to be held prior to the close of the request period provided in the **DATES** section of this document. Requests for an in-person meeting may be made by contacting Appliance and Equipment Standards Program staff at (202) 287-1445 or by email:

Appliance_Standards_Public_Meetings@ee.doe.gov.

B. Submission of Comments

DOE will accept comments, data and information regarding this proposed rule no later than the date provided in the **DATES** section at the beginning of this proposed rule.

Interested parties may submit comments using any of the methods described in the **ADDRESSES** section at the beginning of this NOPR.

Submitting comments via *<http://www.regulations.gov>*. The *<http://www.regulations.gov>* web page will require you to provide your name and contact information. Your contact information will be viewable to DOE Building Technologies staff only. Your contact information will not be publicly viewable except for your first

and last names, organization name (if any), and submitter representative name (if any). If your comment is not processed properly because of technical difficulties, DOE will use this information to contact you. If DOE cannot read your comment due to technical difficulties and cannot contact you for clarification, DOE may not be able to consider your comment.

However, your contact information will be publicly viewable if you include it in the comment or in any documents attached to your comment. Any information that you do not want to be publicly viewable should not be included in your comment, nor in any document attached to your comment. Persons viewing comments will see only first and last names, organization names, correspondence containing comments, and any documents submitted with the comments.

Do not submit to <http://www.regulations.gov> information for which disclosure is restricted by statute, such as trade secrets and commercial or financial information (hereinafter referred to as Confidential Business Information (“CBI”). Comments submitted through <http://www.regulations.gov> cannot be claimed as CBI. Comments received through the website will waive any CBI claims for the information submitted. For information on submitting CBI, see the Confidential Business Information section.

DOE processes submissions made through <http://www.regulations.gov> before posting. Normally, comments will be posted within a few days of being submitted. However, if large volumes of comments are being processed simultaneously, your comment may not be viewable for up to several weeks. Please keep the comment tracking number that <http://www.regulations.gov> provides after you have successfully uploaded your comment.

Submitting comments via email, hand delivery, or postal mail. Comments and documents submitted via email, hand delivery, or postal mail also will be posted to <http://www.regulations.gov>. If you do not want your personal contact information to be publicly viewable, do not include it in your comment or any accompanying documents. Instead, provide your contact information on a cover letter. Include your first and last names, email address, telephone number, and optional mailing address. The cover letter will not be publicly viewable as long as it does not include any comments

Include contact information each time you submit comments, data, documents, and other information to DOE. If you submit via mail or hand delivery, please provide all items on a CD, if feasible. It is not necessary to submit printed copies. No facsimiles (faxes) will be accepted.

Comments, data, and other information submitted to DOE electronically should be provided in PDF (preferred), Microsoft Word or Excel, WordPerfect, or text (ASCII) file format. Provide documents that are not secured, written in English and free of any defects or viruses. Documents should not contain special characters or any form of encryption and, if possible, they should carry the electronic signature of the author.

Campaign form letters. Please submit campaign form letters by the originating organization in batches of between 50 to 500 form letters per PDF or as one form letter with a list of supporters' names compiled into one or more PDFs. This reduces comment processing and posting time.

Confidential Business Information. According to 10 CFR 1004.11, any person submitting information that he or she believes to be confidential and exempt by law from public disclosure should submit via email, postal mail, or hand delivery two well-marked

copies: one copy of the document marked confidential including all the information believed to be confidential, and one copy of the document marked non-confidential with the information believed to be confidential deleted. Submit these documents via email or on a CD, if feasible. DOE will make its own determination about the confidential status of the information and treat it according to its determination.

It is DOE's policy that all comments may be included in the public docket, without change and as received, including any personal information provided in the comments (except information deemed to be exempt from public disclosure).

C. Issues on Which DOE Seeks Comment

Although DOE welcomes comments on any aspect of this proposal, DOE is particularly interested in receiving comments and views of interested parties concerning the following issues:

1. DOE requests comment on its proposed definition for "commercial and industrial power supply" to clarify the scope of applicability of the EPS test procedure. See section III.A for further detail.
2. DOE requests comment on its proposed definition for USB-PD EPSs, and whether it accurately captures the specifications required to distinguish a USB-PD device from other adaptive EPSs. Similarly, DOE requests comments on its proposed definition for the USB Type-C connector and whether it accurately captures the specifications required to distinguish it from other physical port designs that can support adaptive external power supplies. DOE also requests comment on its alternate suggestion for defining a USB-PD EPS by referencing the IEC 62680-1-2 standard, either in its entirety or individual pertinent sections.

For the latter, DOE seeks feedback on which individual sections of IEC 62680-1-2 would be pertinent in distinguishing a USB-PD device from other adaptive EPSs. If neither DOE's proposed definition nor the alternate suggestion is appropriate, DOE requests comment on the appropriate specification to reference as well as the reasons for it. See section III.B for further detail.

3. DOE requests comment on its proposed amendments for USB-PD EPSs; and specifically, whether the 2-amp limit is appropriate for the maximum current at the lowest nameplate output voltage. If this proposed limit is appropriate, please state your reasons why – and if it is not appropriate, why not?
4. DOE seeks comment on its proposal to make more explicit the requirements for testing single-voltage EPSs with multiple output busses. DOE is specifically interested in feedback on whether there are any potential complications with this clarified testing methodology – and if so, the nature of those complications and possible solutions that DOE should consider adopting to address them. See section III.C.1 for further detail.
5. DOE requests comment on whether to treat adaptive EPSs that have both adaptive and non-adaptive output busses as multiple-voltage adaptive EPSs. DOE also requests comment on the proposed testing methods for multiple-voltage adaptive EPSs outlined in the proposed version of paragraph 6(b)(i)(C)(6) of Appendix Z. See section III.C.2 for further detail.
6. DOE requests comment on the proposed update to the test procedure in section 4(i) regarding the disconnecting of functions unrelated to the EPS.

7. DOE requests comment on its proposal to add a new section “Incorporation by Reference” in section 1 of Appendix Z to list the specific sections of IEC 62301 that are referenced in the EPS test procedure at Appendix Z. See section III.C.3 for further detail.
8. DOE requests comment on its proposal to remove redundant definitions that are no longer referenced in either the current or proposed test procedure at Appendix Z. See section III.E.1 for further detail.
9. DOE requests comment on its proposal to move all EPS-related definitions that are currently specified in 10 CFR 430.2 to the EPS test procedure at Appendix Z. See section III.E.2 for further detail.
10. DOE requests comment on its proposal to consolidate the general test requirements for single-voltage and multiple-voltage adaptive and non-adaptive EPSs into section 4 of Appendix Z. See section III.E.3 for further detail.
11. DOE requests comment on its proposal to further clarify that if an EPS can only sustain one output current at any of the output busses it must be tested at the loading condition that allows for the maximum output power on that bus. See section III.E.5 for further detail.
12. DOE requests comment on the accuracy of its understanding of the likely impact of its proposal in relation to the test burden and costs of the current test procedure. See section III.F.1 for further detail.
13. DOE seeks comment on the degree to which the DOE test procedure should consider and be harmonized further with the most recent relevant industry standards for EPSs and whether there are any additional changes to the Federal

test method (not already considered as part of this proposal) that DOE should consider making that would provide additional benefits to the public. DOE also requests comment on the benefits and burdens of adopting any industry/voluntary consensus-based or other appropriate test procedure, without modification. See section III.F.2 for further detail.

14. DOE requests comment on its current determination that there are no small EPS ODMs with manufacturing facilities located in the U.S. See section IV.C for further details.
15. In addition to the issues identified earlier, DOE welcomes comment on any other aspect of the existing test procedure for EPSs not already addressed by the specific areas identified in this document. DOE particularly seeks information that would improve the representativeness of the test procedure, as well as information that would help DOE create a procedure that would limit manufacturer test burden. Comments regarding repeatability and reproducibility are also welcome.

VI. Approval of the Office of the Secretary

The Secretary of Energy has approved publication of this proposed rule.

List of Subjects

10 CFR Part 429

Administrative practice and procedure, Confidential business information, Energy conservation, Household appliances, Reporting and recordkeeping requirements.

10 CFR Part 430

Administrative practice and procedure, Confidential business information, Energy conservation, Household appliances, Imports, Incorporation by reference, Intergovernmental relations, Small businesses.

Signed in Washington, DC, on November 7, 2019.

Alexander N. Fitzsimmons
Acting Deputy Assistant Secretary
for Energy Efficiency
Energy Efficiency and Renewable Energy

For the reasons stated in the preamble, DOE is proposing to amend parts 429 and 430 of Chapter II of Title 10, Code of Federal Regulations as set forth below:

PART 429—CERTIFICATION, COMPLIANCE, AND ENFORCEMENT FOR CONSUMER PRODUCTS AND COMMERCIAL AND INDUSTRIAL EQUIPMENT

1. The authority citation for part 429 continues to read as follows:

Authority: 42 U.S.C. 6291-6317; 28 U.S.C. 2461 note.

2. Section 429.37 is amended by revising paragraphs (b)(2)(ii) and (iii) to read as follows:

§429.37 External power supplies.

* * * * *

(b) * * *

(2) * * *

(ii) Switch-selectable external power supplies: The average active mode efficiency as a percentage (%) value, no-load mode power consumption in watts (W) using the lowest and highest selectable output voltages, nameplate output power in watts (W), and, if missing from the nameplate, the output current in amperes (A).

(iii) Adaptive external power supplies: The average active-mode efficiency as a percentage (%) at the highest and lowest nameplate output voltages, no-load mode power consumption in watts (W), nameplate output power in watts (W) at the highest and lowest nameplate output voltages, and, if missing from the nameplate, the output current in amperes (A) at the highest and lowest nameplate output voltages. For USB-PD EPSs, as defined in appendix Z of part 430, subpart B of this chapter, all of the above values must

be provided but with the loading conditions at the lowest operating voltage scaled such that the output current at the 100%, 75%, 50% and 25% loading conditions are 2A, 1.5A, 1A and 0.5A, respectively. Accordingly, for USB-PD EPSs, certify each adaptive port at 10W at the lowest nameplate output voltage.

* * * * *

PART 430—ENERGY CONSERVATION PROGRAM FOR CONSUMER PRODUCTS

3. The authority citation for part 430 continues to read as follows:

Authority: 42 U.S.C. 6291–6309; 28 U.S.C. 2461 note.

4. Section 430.2 is amended by:

- a. Adding a definition of “Commercial and industrial power supply” in alphabetical order;
- b. Removing the definitions of “Adaptive external power supply (EPS)”, “Basic-voltage external power supply”, “Direct operation external power supply”, “External power supply design family”, “Indirect operation external power supply”, and “Low-voltage external power supply”; and
- c. Revising the definition of “External power supply”.

The addition and revision reads as follows:

§430.2 Definitions.

* * * * *

Commercial and industrial power supply means a power supply that is used to convert electric current into DC or lower-voltage AC current, is not distributed in commerce for use with a consumer product, and includes any of the following characteristics:

- (1) A power supply that require a 3-phase input power and that is incapable of operating on household current;
- (2) A DC-DC only power supply that is incapable of operating on household current;
- (3) A power supply with a fixed, non-removable connection to an end-use device that is not a consumer product as defined under the Energy Policy and Conservation Act of 1975 (as amended);
- (4) A power supply whose output connector is uniquely shaped to fit only an end-use device that is not a consumer product;
- (5) A power supply that cannot be readily connected to an end-use device that is a consumer product without significant modification or customization of the power supply itself or the end-use device;
- (6) A power supply packaged with an end-use device that is not a consumer product, as evidenced by either:
 - (i) Such device being certified as, or declared to be in conformance with, a specific standard applicable only to non-consumer products. For example, a power supply model intended for use with an end-use device that is certified to the following standards would not meet the EPCA definition of an EPS:
 - (A) CISPR 11 (Class A Equipment), “Industrial, scientific and medical equipment – Radio-frequency disturbance – Limits and methods of measurement”;
 - (B) UL 1480A, “Standard for Speakers for Commercial and Professional Use”;
 - (C) UL 813, “Standard for Commercial Audio Equipment”;
and
 - (D) UL 1727, “Standard for Commercial Electric Personal Grooming Appliances”;

(ii) Such device being excluded or exempted from inclusion within, or conformance with, a law, regulation, or broadly-accepted industry standard where such exclusion or exemption applies only to non-consumer products;

(7) A power supply distributed in commerce for use with an end-use device where:

(i) The end-use device is not a consumer product, as evidenced by either the circumstances in paragraph (6)(i) or (ii) of this definition; and

(ii) The end-use device for which the power supply is distributed in commerce is reasonably disclosed to the public, such as by identification of the end-use device on the packaging for the power supply, documentation physically present with the power supply, or on the manufacturer's or private labeler's public website; or

(8) A power supply that is not marketed for residential or consumer use, and that is clearly marked (or, alternatively, the packaging of the individual power supply, the shipping container of multiple such power supplies, or associated documentation physically present with the power supply when distributed in commerce is clearly marked) "FOR USE WITH COMMERCIAL OR INDUSTRIAL EQUIPMENT ONLY" or "NOT FOR RESIDENTIAL OR CONSUMER USE," with the marking designed and applied so that the marking will be visible and legible during customary conditions for the item on which the marking is placed.

* * * * *

External power supply means an external power supply circuit that is used to convert household electric current into DC current or lower-voltage AC current to operate a consumer product. However, the term does not include any "commercial and industrial

power supply” as defined in this section, or a power supply circuit, driver, or device that is designed exclusively to be connected to, and power—

- (1) Light-emitting diodes providing illumination;
- (2) Organic light-emitting diodes providing illumination; or
- (3) Ceiling fans using direct current motors.

* * * * *

5. Section 430.23 is amended by revising paragraph (bb) to read as follows:

§430.23 Test procedures for the measurement of energy and water consumption.

* * * * *

(bb) *External Power Supplies.* The energy consumption of an external power supply, including active-mode efficiency expressed as a percentage and the no-load, off, and standby mode energy consumption levels expressed in watts, shall be measured in accordance with appendix Z of this subpart.

* * * * *

6. Appendix Z is revised to read as follows:

Appendix Z to Subpart B of Part 430—Uniform Test Method for Measuring the Energy Consumption of External Power Supplies

Note: Starting on [DATE 180 days after publication of the final rule in the *Federal Register*], manufacturers must make any representations regarding the energy efficiency or power consumption of external power supplies based upon results generated under this appendix. Prior to that date manufacturers must make any representations regarding the energy efficiency or power consumption of external power supplies based upon results generated under Appendix Z as it appeared at 10 CFR part 430, subpart B revised as of January 1, 2018.

1. *Incorporation by reference*

DOE incorporated by reference the entire standard for IEC 62301 in §430.3; however, only enumerated provisions of this document is applicable to this appendix, as follows:

(a) IEC 62301, (“IEC 62301-Z”), Household electrical appliances – Measurement of standby power, (Edition 2.0, 2011-01), as follows:

- (i) Section 4.3.2 “Supply voltage waveform”;
- (ii) Section 4.4.1 “Power measurement uncertainty”;
- (iii) Section 5.3.3 “Average reading method”;
- (iv) Annex B “Notes on the measurement of low power modes”; and
- (v) Annex D “Determination of uncertainty of measurement.”

(b) Reserved.

2. *Scope.*

This appendix covers the test requirements used to measure the energy consumption of direct operation external power supplies and indirect operation Class A external power supplies subject to the energy conservation standards set forth at §430.32(w)(1).

3. *Definitions:* The following definitions are for the purposes of understanding terminology associated with the test method for measuring external power supply energy consumption.

Active mode means the mode of operation when the external power supply is connected to the main electricity supply and the output is (or “all outputs are” for external power supplies with multiple outputs) connected to a load (or “loads” for external power supplies with multiple outputs).

Active mode efficiency is the ratio, expressed as a percentage, of the total real output power produced by a power supply to the real input power required to produce it.

(Reference for guidance only, see IEEE Standard 1515-2000, 4.3.1.1, §430.4.)

Active power (P) (also *real power*) means the average power consumed by a unit. For a two terminal device with current and voltage waveforms $i(t)$ and $v(t)$, respectively, which are periodic with period T , the real or active power P is:

$$P = \frac{1}{T} \int_0^T v(t)i(t)dt$$

Adaptive external power supply means an external power supply that can alter its output voltage during active-mode based on an established digital communication protocol with the end-use application without any user-generated action.

Ambient temperature means the temperature of the ambient air immediately surrounding the unit under test.

Average Active-Mode Efficiency means the average of the active mode efficiencies at the loading conditions (100%, 75%, 50%, and 25% of unit under test's nameplate output current) for which that unit can sustain the output current.

Basic-voltage external power supply means an external power supply that is not a low-voltage external power supply.

Class A external power supply—

(1) Means an external power supply device that—

- (i) Is designed to convert line voltage AC input into lower voltage AC or DC output;
- (ii) Is able to convert to only one AC or DC output voltage at a time;

- (iii) Is sold with, or intended to be used with, a separate end-use product that constitutes the primary load;
 - (iv) Is contained in a separate physical enclosure from the end-use product;
 - (v) Is connected to the end-use product via a removable or hard-wired male/female electrical connection, cable, cord, or other wiring; and
 - (vi) Has nameplate output power that is less than or equal to 250 watts;
- (2) But, excludes any device that—
- (i) Requires Federal Food and Drug Administration listing and approval as a medical device in accordance with section 513 of the Federal Food, Drug, and Cosmetic Act (21 U.S.C. 360(c)); or
 - (ii) Powers the charger of a detachable battery pack or charges the battery of a product that is fully or primarily motor-operated.

Direct operation external power supply means an external power supply that can operate a consumer product that is not a battery charger without the assistance of a battery.

IEC 62301-Z means the test standard published by the International Electrotechnical Commission, titled “Household electrical appliances—Measurement of standby power,” as limited in section 1 of this appendix.

Indirect operation external power supply means an external power supply that cannot operate a consumer product that is not a battery charger without the assistance of a battery as determined by the steps in paragraphs (1)(i) through (v) of this definition:

- (1) If the external power supply can be connected to an end-use consumer product and that consumer product can be operated using battery power, the method for determining

whether that external power supply is incapable of operating that consumer product directly is as follows:

(i) If the end-use product has a removable battery, remove it for the remainder of the test and proceed to the step in paragraph (1)(v) of this definition. If not, proceed to the step in paragraph (1)(ii) of this definition.

(ii) Charge the battery in the application via the external power supply such that the application can operate as intended before taking any additional steps.

(iii) Disconnect the external power supply from the application. From an off-mode state, turn on the application and record the time necessary for it to become operational to the nearest five second increment (5 sec, 10 sec, etc.).

(iv) Operate the application using power only from the battery until the application stops functioning due to the battery discharging.

(v) Connect the external power supply first to mains and then to the application.

Immediately attempt to operate the application. If the battery was removed for testing and the end-use product operates as intended, the external power supply is not an indirect operation external power supply and paragraph 2 of this definition does not apply. If the battery could not be removed for testing, record the time for the application to become operational to the nearest five second increment (5 seconds, 10 seconds, etc.).

(2) If the time recorded in paragraph (1)(v) of this definition is greater than the summation of the time recorded in paragraph (1)(iii) of this definition and five seconds, the external power supply cannot operate the application directly and is an indirect operation external power supply.

Low-voltage external power supply means an external power supply with a nameplate output voltage less than 6 volts and nameplate output current greater than or equal to 550 milliamps.

Manual on-off switch is a switch activated by the user to control power reaching the device. This term does not apply to any mechanical, optical, or electronic switches that automatically disconnect mains power from the device when a load is disconnected from the device, or that control power to the load itself.

Minimum output current means the minimum current that must be drawn from an output bus for an external power supply to operate within its specifications.

Multiple-voltage external power supply means an external power supply that is designed to convert line voltage AC input into more than one simultaneous lower-voltage output.

Nameplate output current means the current output of the power supply as specified on the manufacturer's label on the power supply housing (either DC or AC) or, if absent from the housing, as provided by the manufacturer.

Nameplate output power means the power output of the power supply as specified on the manufacturer's label on the power supply housing or, if absent from the housing, as specified in documentation provided by the manufacturer. For an adaptive external power supply with USB-PD ports, the nameplate output power is 10W at the 5 volt level per USB-PD port and as specified on the manufacturer's label or documentation at the highest voltage.

Nameplate output voltage means the voltage output of the power supply as specified on the manufacturer's label on the power supply housing (either DC or AC).

No-load mode means the mode of operation when an external power supply is connected to the main electricity supply and the output is (or “all outputs are” for a multiple-voltage external power supply) not connected to a load (or “loads” for a multiple-voltage external power supply).

Off-mode is the condition, applicable only to units with manual on-off switches, in which the external power supply is

- (1) Connected to the main electricity supply;
- (2) The output is not connected to any load; and
- (3) All manual on-off switches are turned off.

Output bus means any of the outputs of the power supply to which loads can be connected and from which power can be drawn, as opposed to signal connections used for communication.

RMS means root mean square.

Single-voltage external AC-AC power supply means an external power supply that is designed to convert line voltage AC input into lower voltage AC output and is able to convert to only one AC output voltage at a time.

Standby mode means the condition in which the external power supply is in no-load mode and, for external power supplies with manual on-off switches, all such switches are turned on.

Switch-selectable single voltage external power supply means a single-voltage AC-AC or AC-DC power supply that allows users to choose from more than one output voltage.

Total harmonic distortion (“THD”), expressed as a percentage, is the RMS value of an AC signal after the fundamental component is removed and interharmonic components

are ignored, divided by the RMS value of the fundamental component. THD of current is defined as:

$$THD = \frac{\sqrt{I_2^2 + I_3^2 + I_4^2 + \dots I_n^2}}{I_1}$$

where I_n is the RMS value of the n th harmonic of the current signal.

Unit under test (“UUT”) is the external power supply being tested.

USB Power Delivery (“USB-PD”) EPS means an adaptive EPS that utilizes a USB Type-C output port and uses a digital protocol to communicate between the EPS and the end-user product to automatically switch between an output voltage of 5 volts and one or more of the following voltages: 9 volts, 15 volts, or 20 volts. The USB-PD output bus must be capable of delivering 3 amps at an output voltage of 5 volts, and the voltages and currents must not exceed any of the following values for the supported voltages: 3 amps at 9 volts; 3 amps at 15 volts, and; 5 amps at 20 volts.

USB Type-C means the reversible 24-pin physical USB connector system that supports USB-PD and allows for the transmission of data and power between compatible USB products.

4. *Test Apparatus and General Instructions*

(a) Any power measurements recorded, as well as any power measurement equipment utilized for testing, shall conform to the uncertainty and resolution specifications in section 4.4.1, “Power measurement uncertainty,” as well as Annexes B, “Notes on the measurement of low power modes,” and D, “Determination of uncertainty of measurement,” of IEC 62301-Z.

- (b) Carry out tests in a room that has an air speed close to the unit under test (UUT) of ≤ 0.5 m/s. Maintain ambient temperature at 20 ± 5 °C throughout the test. Do not intentionally cool the UUT, for example, by use of separately powered fans, air conditioners, or heat sinks. Test the UUT on a thermally non-conductive surface. Products intended for outdoor use may be tested at additional temperatures, provided those are in addition to the conditions specified above and are noted in a separate section on the test report.
- (c) If the UUT is intended for operation on AC line-voltage input in the United States, test it at 115 V at 60 Hz. If the UUT is intended for operation on AC line-voltage input but cannot be operated at 115 V at 60 Hz, do not test it. Ensure the input voltage is within $\pm 1\%$ of the above specified voltage and the input frequency is within $\pm 1\%$ of the specified frequency.
- (d) The input voltage source must be capable of delivering at least 10 times the nameplate input power of the UUT as is specified in IEEE 1515-2000 (Referenced for guidance only, see §430.4). Regardless of the AC source type, the THD of the supply voltage when supplying the UUT in the specified mode must not exceed 2%, up to and including the 13th harmonic. The peak value of the test voltage must be within 1.34 and 1.49 multiplied by its RMS value.
- (e) Select all leads used in the test set-up with appropriate wire gauges and lengths to minimize voltage drops across the wires during testing. See Table B.2— “Commonly used values for wire gages [*sic*] and related voltage drops” in IEEE 1515-2000 for further guidance (Referenced for guidance only; see §430.4).

(f) Test Load. To load the power supply to produce all active-mode loading conditions, use passive loads, such as rheostats, or active loads, such as electronic loads. Resistive loads need not be measured precisely with an ohmmeter; simply adjust a variable resistor to the point where the ammeter confirms that the desired percentage of nameplate output current is flowing. For electronic loads, adjust the desired output current in constant current mode rather than adjusting the required output power in constant power mode.

(g) Test the external power supply at the end of the wire or cord that connects to an end-use product, regardless of whether the end of the wire or cord is integrated into an end-use product or plugs into and out of an end-use product. If a separate wire or cord is provided by the manufacturer to connect the external power supply to an end-use product, use this wire or cord and perform tests at the end of the cord that connects to an end-use product. If a wire or cord is not supplied by the manufacturer, test the external power supply at the output electrical contact that can be connected to a physical wire. If the connection to an end-use product is removable, there are two options for connecting metering equipment to the output connection of the external power supply:

(1) Cut the cord immediately adjacent to the output connector, or

(2) Attach leads and measure the efficiency from the output connector itself. If the connection to an end-use product is not removable, cut the cord immediately adjacent to the powered product and connect measurement probes at that point. Connect any additional metering equipment such as voltmeters and/or ammeters used in conjunction with resistive or electronic loads directly to the end of the output cable of the UUT.

Conduct the tests on the sets of output wires that constitute the output busses. If the product has more than two output wires, including those wires that are necessary for

controlling the product, the manufacturer must supply a connection diagram or test fixture that will allow the testing laboratory to put the UUT into active-mode. Figure 1 of this section provides one illustration of how to set up a single-voltage external power supply for testing; however, the actual test setup may vary pursuant to the type of external power supply being tested and the requirements of this appendix.

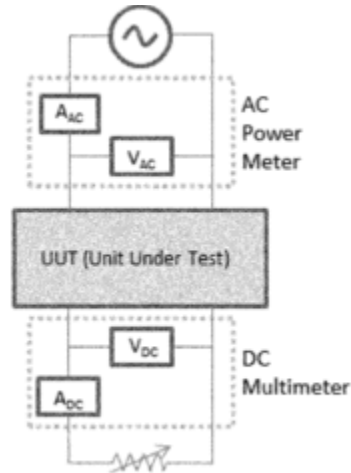

Figure 1. Example Connection Diagram for Single-Voltage External Power Supply Efficiency Measurements

(h) While external power supplies must be tested in their final, completed configuration in order to represent their measured efficiency on product labels or specification sheets, any functionality that is unrelated to the external power supply circuit may be disconnected during testing as long as the disconnection does not impact the functionality of the external power supply itself. Test the external power supply in its final configuration to the extent possible (within its enclosure and with all output cords that are shipped with it).

(i) If a product serves one or more other major functions in addition to converting household electric current into DC current or lower-voltage AC current, components of the product that serve other functions may be disconnected before testing so that test

measurements do not include power used by other functions and as long as disconnecting such components do not affect the ability of the product to convert household electric current into DC current or lower-voltage AC current. For example, consider a surge protector that offers outlets supplying AC household electric current and one or more USB outputs supplying DC current. If power is provided to the AC outlets through a surge protection circuit, but power to the USB outlet(s) is not, then the surge protection circuit may be disconnected from AC power during testing. Similarly, if a lighted manual on-off switch disconnects power only to the AC outlets, but not the USB outputs, then the manual on-off switch may be turned off and power to the light disconnected during testing.

5. Test Measurement for all External Power Supplies other than Adaptive External Power Supplies:

(a) Single-Voltage External Power Supply

(1) Standby Mode and Active-Mode Measurement.

(i) Place in the “on” position any built-in switch in the UUT controlling power flow to the AC input, and note the existence of such a switch in the final test report.

(ii) Operate the UUT at 100% of nameplate output current for at least 30 minutes immediately prior to conducting efficiency measurements. After this warm-up period, monitor AC input power for a period of 5 minutes to assess the stability of the UUT. If the power level does not drift by more than 5% from the maximum value observed, the UUT is considered stable. If the UUT is stable, record the measurements obtained at the end of this 5-minute period. Measure subsequent loading conditions under the same 5-minute stability parameters. Note that only one warm-up period of 30 minutes is required

for each UUT at the beginning of the test procedure. If the AC input power is not stable over a 5-minute period, follow the guidelines established by section 5.3.3 of IEC 62301-Z for measuring average power or accumulated energy over time for both input and output.

(iii) Test the UUT at the nameplate output voltage(s) at the loading conditions listed in Table 1, derated per the proportional allocation method presented in paragraph 5(a)(1)(iv) of this appendix. Conduct efficiency measurements in sequence from Loading Condition 1 to Loading Condition 4 as indicated in Table 1 of this section. For Loading Condition 5, place the UUT in no-load mode, disconnect any additional signal connections to the UUT, and measure input power.

Table 1—Loading Conditions for Unit Under Test

Loading Condition 1	100% of Derated Nameplate Output Current $\pm 2\%$.
Loading Condition 2	75% of Derated Nameplate Output Current $\pm 2\%$.
Loading Condition 3	50% of Derated Nameplate Output Current $\pm 2\%$.
Loading Condition 4	25% of Derated Nameplate Output Current $\pm 2\%$.
Loading Condition 5	0%.

The 2% allowance pertains to nameplate output current, not the calculated current value. For example, a UUT at Loading Condition 3 may be tested in a range from 48% to 52% of the derated output current.

(A) If testing of additional, optional loading conditions is desired, conduct that testing in accordance with this test procedure and subsequent to completing the sequence described in paragraph 5(a)(1)(iii) of this appendix.

(B) Where the external power supply lists both an instantaneous and continuous output current, test the external power supply at the continuous condition only.

(C) If an external power supply cannot sustain output at one or more of the Loading Conditions 1–4 as specified in Table 1, test the external power supply only at the loading conditions for which it can sustain output.

(iv) Proportional allocation method for loading single-voltage external power supplies with multiple busses. Use the following proportional allocation method to provide consistent loading conditions for single-voltage external power supplies with multiple output busses. For additional explanation (provided for guidance only), please refer to section 6.1.1 of the California Energy Commission's “Generalized Test Protocol for Calculating the Energy Efficiency of Internal Ac-Dc Power Supplies Revision 6.7,” March 2014.

(A) Consider a power supply with N output busses, each with the same nameplate output voltages V_1, \dots, V_N , corresponding output current ratings I_1, \dots, I_N , and a nameplate output power P. Calculate the derating factor D by dividing the power supply maximum output power P by the sum of the maximum output powers of the individual output busses, equal to the product of port nameplate output voltage and current $I_i V_i$, as follows:

$$D = \frac{P}{\sum_{i=1}^N V_i I_i},$$

(B) If $D \geq 1$, then loading every port to its nameplate output current does not exceed the overall maximum output power for the power supply. In this case, load each output bus to the percentages of its nameplate output current listed in Table 1. However, if $D < 1$, it is an indication that loading each port to its nameplate output current will exceed the overall maximum output power for the power supply. In this case, and at each loading condition,

load each output bus to the appropriate percentage of its nameplate output current as listed in Table 1, multiplied by the derating factor D.

(v) Test switch-selectable single-voltage external power supplies twice—once at the highest nameplate output voltage and once at the lowest.

(vi) Efficiency calculation. Calculate and record efficiency at each loading point by dividing the UUT's measured active output power at a given loading condition by the active AC input power measured at that loading condition.

(A) Calculate and record average efficiency of the UUT as the arithmetic mean of the efficiency values calculated at Loading Conditions 1, 2, 3, and 4 in Table 1 of this section.

(B) If, when tested, a UUT cannot sustain output current at one or more of the loading conditions as specified in Table 1, the average active-mode efficiency is calculated as the average of the loading conditions for which it can sustain output.

(C) If the UUT can only sustain one output current at any of the output busses, test it at the loading condition that allows for the maximum output power on that bus (i.e. the highest output current possible at the highest output voltage on that bus).

(vii) Power consumption calculation. The power consumption of Loading Condition 5 (no-load) is equal to the active AC input power (W) at that loading condition.

(viii) Off-Mode Measurement. If the UUT incorporates manual on-off switches, place the UUT in off-mode, and measure and record its power consumption at Loading Condition 5 in Table 1 of this section. The measurement of the off-mode energy consumption must conform to the requirements specified in section 5(a)(1) of this appendix, except that all manual on-off switches must be placed in the “off” position for

the off-mode measurement. The UUT is considered stable if, over 5 minutes with samples taken at least once every second, the AC input power does not drift from the maximum value observed by more than 1% or 50 milliwatts, whichever is greater.

Measure the off-mode power consumption of a switch-selectable single-voltage external power supply twice—once at the highest nameplate output voltage and once at the lowest.

(b) Multiple-Voltage External Power Supply

(1) Standby-Mode and Active-Mode Measurement

(i) Place in the “on” position any built-in switch in the UUT controlling power flow to the AC input, and note the existence of such a switch in the final test report.

(ii) Operate the UUT at 100% of nameplate output current for at least 30 minutes immediately prior to conducting efficiency measurements. After this warm-up period, monitor AC input power for a period of 5 minutes to assess the stability of the UUT. If the power level does not drift by more than 1% from the maximum value observed, the UUT is considered stable. If the UUT is stable, record the measurements obtained at the end of this 5-minute period. Measure subsequent loading conditions under the same 5-minute stability parameters. Note that only one warm-up period of 30 minutes is required for each UUT at the beginning of the test procedure. If the AC input power is not stable over a 5-minute period, follow the guidelines established by section 5.3.3 of IEC 62301-Z for measuring average power or accumulated energy over time for both input and output.

(iii) Test the UUT at the nameplate output voltage(s) at the loading conditions listed in Table 2, derated per the proportional allocation method presented in paragraph 5(b)(1)(iv) of this appendix. Active or passive loads used for efficiency testing of the UUT must

maintain the required current loading set point for each output voltage within an accuracy of $\pm 0.5\%$. Conduct efficiency measurements in sequence from Loading Condition 1 to Loading Condition 4 as indicated in Table 2. For Loading Condition 5, place the UUT in no-load mode, disconnect any additional signal connections to the UUT, and measure input power.

Table 2—Loading Conditions for Unit Under Test

Loading Condition 1	100% of Derated Nameplate Output Current $\pm 2\%$.
Loading Condition 2	75% of Derated Nameplate Output Current $\pm 2\%$.
Loading Condition 3	50% of Derated Nameplate Output Current $\pm 2\%$.
Loading Condition 4	25% of Derated Nameplate Output Current $\pm 2\%$.
Loading Condition 5	0%.

The 2% allowance pertains to nameplate output current, not the calculated current value. For example, a UUT at Loading Condition 3 may be tested in a range from 48% to 52% of the derated output current.

(A) If testing of additional, optional loading conditions is desired, conduct that testing in accordance with this test procedure and subsequent to completing the sequence described in paragraph 5(b)(1)(iii) of this appendix.

(B) Where the external power supply lists both an instantaneous and continuous output current, test the external power supply at the continuous condition only.

(C) If an external power supply cannot sustain output at one or more of the Loading Conditions 1–4 as specified in Table 2 of this section, test the external power supply only at the loading conditions for which it can sustain output.

(iv) Proportional allocation method for loading multiple-voltage external power supplies.

Use the following proportional allocation method to provide consistent loading conditions for multiple-voltage external power supplies. For additional explanation

(provided for guidance only), please refer to section 6.1.1 of the California Energy Commission's "Proposed Test Protocol for Calculating the Energy Efficiency of Internal Ac-Dc Power Supplies Revision 6.7," March 2014.

(A) Consider a power supply with N output busses, and nameplate output voltages V_1, \dots, V_N , corresponding output current ratings I_1, \dots, I_N , and a maximum output power P as specified on the manufacturer's label on the power supply housing, or, if absent from the housing, as specified in the documentation provided with the unit by the manufacturer. Calculate the derating factor D by dividing the power supply maximum output power P by the sum of the maximum output powers of the individual output busses, equal to the product of bus nameplate output voltage and current $V_i I_i$, as follows:

$$D = \frac{P}{\sum_{i=1}^N V_i I_i},$$

(B) If $D \geq 1$, then loading every bus to its nameplate output current does not exceed the overall maximum output power for the power supply. In this case, load each output bus to the percentages of its nameplate output current listed in Table 2. However, if $D < 1$, it is an indication that loading each bus to its nameplate output current will exceed the overall maximum output power for the power supply. In this case, and at each loading condition, load each output bus to the appropriate percentage of its nameplate output current listed in Table 2, multiplied by the derating factor D.

(v) Minimum output current requirements. Depending on their application, some multiple-voltage power supplies may require a minimum output current for each output bus of the power supply for correct operation. In these cases, ensure that the load current for each output at Loading Condition 4 in Table 2 is greater than the minimum output current requirement. Thus, if the test method's calculated load current for a given voltage

bus is smaller than the minimum output current requirement, the minimum output current must be used to load the bus. This load current shall be properly recorded in any test report.

(vi) Efficiency calculation. Calculate and record efficiency at each loading point by dividing the UUT's measured active output power at a given loading condition by the active AC input power measured at that loading condition.

(A) Calculate and record average efficiency of the UUT as the arithmetic mean of the efficiency values calculated at Loading Conditions 1, 2, 3, and 4, in Table 2 of this section.

(B) If, when tested, a UUT cannot sustain output current at one or more of the loading conditions as specified in Table 2 of this section, the average active mode efficiency is calculated as the average of the loading conditions for which it can sustain output.

(C) If the UUT can only sustain one output current at any of the output busses, test it at the loading condition that allows for the maximum output power on that bus (i.e. the highest output current possible at the highest output voltage on that bus).

(vii) Power consumption calculation. The power consumption of Loading Condition 5 (no-load) is equal to the active AC input power (W) at that loading condition.

(2) Off-mode Measurement—If the UUT incorporates manual on-off switches, place the UUT in off-mode and measure and record its power consumption at Loading Condition 5 in Table 2 of this section. The measurement of the off-mode energy consumption must conform to the requirements specified in paragraph (5)(b)(1) of this appendix, except that all manual on-off switches must be placed in the “off” position for the off-mode measurement. The UUT is considered stable if, over 5 minutes with samples taken at

least once every second, the AC input power does not drift from the maximum value observed by more than 1% or 50 milliwatts, whichever is greater.

6. Test Measurement for Adaptive External Power Supplies:

(a) Single-Voltage Adaptive External Power Supply.

(1) Standby Mode and Active-Mode Measurement.

(i) Place in the “on” position any built-in switch in the UUT controlling power flow to the AC input, and note the existence of such a switch in the final test report.

(ii) Operate the UUT at 100% of nameplate output current for at least 30 minutes immediately prior to conducting efficiency measurements. After this warm-up period, monitor AC input power for a period of 5 minutes to assess the stability of the UUT. If the power level does not drift by more than 5% from the maximum value observed, the UUT is considered stable. If the UUT is stable, record the measurements obtained at the end of this 5-minute period. Measure subsequent loading conditions under the same 5-minute stability parameters. Note that only one warm-up period of 30 minutes is required for each UUT at the beginning of the test procedure. If the AC input power is not stable over a 5-minute period, follow the guidelines established by section 5.3.3 of IEC 62301-Z for measuring average power or accumulated energy over time for both input and output.

(iii) Test the UUT at the nameplate output voltage(s) at the loading conditions listed in Table 3, derated per the proportional allocation method presented in paragraph 6(a)(1)(iv) of this appendix. Adaptive external power supplies must be tested twice – once at the highest nameplate output voltage and once at the lowest nameplate output voltage as described in the following sections.

(A) At the highest nameplate output voltage, test adaptive external power supplies in sequence from Loading Condition 1 to Loading Condition 4, as indicated in Table 3 of this section. For Loading Condition 5, place the UUT in no-load mode, disconnect any additional signal connections, and measure the input power.

(B) At the lowest nameplate output voltage, with the exception of USB-PD EPSs, test all adaptive external power supplies in sequence from Loading Condition 1 to Loading Condition 4, as indicated in Table 3 of this section. For USB-PD adaptive external power supplies, at the lowest nameplate output voltage, test the external power supply such that for Loading Conditions 1, 2, 3, and 4, all adaptive ports are loaded to 2 amperes, 1.5 amperes, 1 ampere and 0.5 amperes respectively. All non-adaptive ports will continue to be loaded as indicated in Table 3 of this section. For Loading Condition 5, test all adaptive external power supplies by placing the UUT in no-load mode, disconnecting any additional signal connections, and measuring the input power.

Table 3—Loading Conditions for a Single-Voltage Adaptive External Power Supply

Loading Condition 1	100% of Derated Nameplate Output Current $\pm 2\%$.
Loading Condition 2	75% of Derated Nameplate Output Current $\pm 2\%$.
Loading Condition 3	50% of Derated Nameplate Output Current $\pm 2\%$.
Loading Condition 4	25% of Derated Nameplate Output Current $\pm 2\%$.
Loading Condition 5	0%.

The 2% allowance pertains to nameplate output current, not the calculated current value. For example, a UUT at Loading Condition 3 may be tested in a range from 48% to 52% of the derated output current.

(C) If testing of additional, optional loading conditions is desired, conduct that testing in accordance with this test procedure and subsequent to completing the sequence described in paragraph 6(a)(1)(iii) of this appendix.

(D) Where the external power supply lists both an instantaneous and continuous output current, test the external power supply at the continuous condition only.

(E) If an external power supply cannot sustain output at one or more of the Loading Conditions 1–4 as specified in Table 3 of this section, test the external power supply only at the loading conditions for which it can sustain output.

(iv) Proportional allocation method for loading single-voltage adaptive external power supplies with multiple ports. Use the following proportional allocation method to provide consistent loading conditions for single-voltage adaptive external power supplies with multiple output busses. For additional explanation, please refer to section 6.1.1 of the California Energy Commission's "Proposed Test Protocol for Calculating the Energy Efficiency of Internal Ac-Dc Power Supplies Revision 6.7," March 2014.

(A) Consider a power supply with N output busses, each with the same nameplate output voltages $V_1, * * *, V_N$, corresponding output current ratings $I_1, * * *, I_N$, and a maximum output power P as specified on the manufacturer's label on the power supply housing, or, if absent from the housing, as specified in the documentation provided with the unit by the manufacturer. Calculate the derating factor D by dividing the power supply maximum output power P by the sum of the maximum output powers of the individual output busses, equal to the product of port nameplate output voltage and current $I_i V_i$, as follows:

$$D = \frac{P}{\sum_{i=1}^N V_i I_i}$$

For USB-PD adaptive external power supplies, at the lowest nameplate output voltage, limit the contribution from each port to 10W when calculating the derating factor.

(B) If $D \geq 1$, then loading every port to its nameplate output current does not exceed the overall maximum output power for the power supply. In this case, load each output bus to the percentages of its nameplate output current listed in Table 3 of this section. However, if $D < 1$, it is an indication that loading each port to its nameplate output current will exceed the overall maximum output power for the power supply. In this case, and at each loading condition, each output bus will be loaded to the appropriate percentage of its nameplate output current listed in Table 3 of this section, multiplied by the derating factor D .

(v) Efficiency calculation. Calculate and record the efficiency at each loading point by dividing the UUT's measured active output power at that loading condition by the active AC input power measured at that loading condition.

(A) Calculate and record average efficiency of the UUT as the arithmetic mean of the efficiency values calculated at loading conditions 1, 2, 3, and 4 in Table 3 of this section.

(B) If, when tested, a UUT cannot sustain the output current at one or more of the loading conditions as specified in Table 3 of this section, the average active-mode efficiency is calculated as the average of the Loading Conditions for which it can sustain output.

(C) If the UUT can only sustain one output current at any of the output busses, test it at the loading condition that allows for the maximum output power on that bus (i.e. the highest output current possible at the highest output voltage on that bus).

(vi) Power consumption calculation. The power consumption of Loading Condition 5 (no-load) is equal to the active AC input power (W) at that loading condition.

(2) Off-Mode Measurement—If the UUT incorporates manual on-off switches, place the UUT in off-mode, and measure and record its power consumption at loading condition 5

in Table 3. The measurement of the off-mode energy consumption must conform to the requirements specified in paragraph 6(a)(1) of this appendix, except that all manual on-off switches must be placed in the “off” position for the off-mode measurement. The UUT is considered stable if, over 5 minutes with samples taken at least once every second, the AC input power does not drift from the maximum value observed by more than 1% or 50 milliwatts, whichever is greater. Measure the off-mode power consumption of a single-voltage adaptive external power supply twice - once at the highest nameplate output voltage and once at the lowest.

(b) Multiple-Voltage Adaptive External Power Supply.

(1) Standby Mode and Active-Mode Measurement.

(i) Place in the “on” position any built-in switch in the UUT controlling power flow to the AC input, and note the existence of such a switch in the final test report.

(ii) Operate the UUT at 100% of nameplate output current for at least 30 minutes immediately prior to conducting efficiency measurements. After this warm-up period, monitor AC input power for a period of 5 minutes to assess the stability of the UUT. If the power level does not drift by more than 1% from the maximum value observed, the UUT is considered stable. If the UUT is stable, record the measurements obtained at the end of this 5-minute period. Measure subsequent loading conditions under the same 5-minute stability parameters. Note that only one warm-up period of 30 minutes is required for each UUT at the beginning of the test procedure. If the AC input power is not stable over a 5-minute period, follow the guidelines established by section 5.3.3 of IEC 62301-Z for measuring average power or accumulated energy over time for both input and output.

(iii) Test the UUT at the nameplate output voltage(s) at the loading conditions listed in Table 4, derated per the proportional allocation method presented in paragraph 6(b)(1)(iv) of this appendix. Active or passive loads used for efficiency testing of the UUT must maintain the required current loading set point for each output voltage within an accuracy of $\pm 0.5\%$. Adaptive external power supplies must be tested twice – once at the highest nameplate output voltage and once at the lowest nameplate output voltage as described in the following sections.

(A) At the highest nameplate output voltage, test adaptive external power supplies in sequence from Loading Condition 1 to Loading Condition 4, as indicated in Table 4 of this section. For Loading Condition 5, place the UUT in no-load mode, disconnect any additional signal connections, and measure the input power.

(B) At the lowest nameplate output voltage, with the exception of USB-PD EPSs, test all other adaptive external power supplies, in sequence from Loading Condition 1 to Loading Condition 4, as indicated in Table 4 of this section. For USB-PD adaptive external power supplies, at the lowest nameplate output voltage, test the external power supply such that for Loading Conditions 1, 2, 3, and 4, all adaptive ports are loaded to 2 amperes, 1.5 amperes, 1 ampere and 0.5 amperes respectively. All non-adaptive ports will continue to be loaded as indicated in Table 4 of this section. For loading condition 5, test all adaptive external power supplies by placing the UUT in no-load mode, disconnecting any additional signal connections, and measuring the input power.

Table 4—Loading Conditions for a Multiple-Voltage Adaptive External Power Supply

Loading Condition 1	100% of Derated Nameplate Output Current $\pm 2\%$.
Loading Condition 2	75% of Derated Nameplate Output Current $\pm 2\%$.
Loading Condition 3	50% of Derated Nameplate Output Current $\pm 2\%$.

Loading Condition 4	25% of Derated Nameplate Output Current $\pm 2\%$.
Loading Condition 5	0%.

The 2% allowance pertains to nameplate output current, not the calculated current value. For example, a UUT at Loading Condition 3 may be tested in a range from 48% to 52% of the derated output current.

(C) If testing of additional, optional loading conditions is desired, conduct that testing in accordance with this test procedure and subsequent to completing the sequence described in paragraph 6(b)(1)(iii) of this appendix.

(D) Where the external power supply lists both an instantaneous and continuous output current, test the external power supply at the continuous condition only.

(E) If an adaptive external power supply is operating as a multiple-voltage external power supply at only the highest nameplate output voltage or lowest nameplate output voltage, test this external power supply as a multiple-voltage adaptive external power supply at both the highest nameplate output voltage and the lowest nameplate output voltage.

(F) If an external power supply has both adaptive and non-adaptive ports, and these ports operate simultaneously at multiple voltages, ensure that testing is performed with all ports active at both the highest and lowest nameplate output voltage. For example, if an external power supply has an USB-PD adaptive output bus that operates at 5 volts and 20 volts and a second non-adaptive output bus that operates at 9 volts, test this EPS at the highest nameplate output voltage with both the adaptive and non-adaptive ports respectively loaded at 20 volts and 9 volts; likewise, test it at the lowest nameplate output voltage with both the adaptive and non-adaptive ports respectively loaded at 5 volts and 9 volts.

(G) If an external power supply cannot sustain output at one or more of the Loading Conditions 1–4 as specified in Table 4 of this section, test the external power supply only at the loading conditions for which it can sustain output.

(iv) Proportional allocation method for loading multiple-voltage adaptive external power supplies. Use the following proportional allocation method to provide consistent loading conditions for multiple-voltage adaptive external power supplies. For additional explanation, please refer to section 6.1.1 of the California Energy Commission's “Proposed Test Protocol for Calculating the Energy Efficiency of Internal Ac-Dc Power Supplies Revision 6.7,” March 2014.

(A) Consider a multiple-voltage power supply with N output busses, and nameplate output voltages V_1, \dots, V_N , corresponding output current ratings I_1, \dots, I_N , and a maximum output power P as specified on the manufacturer’s label on the power supply housing, or, if absent from the housing, as specified in the documentation provided with the unit by the manufacturer. Calculate the derating factor D by dividing the power supply maximum output power P by the sum of the maximum output powers of the individual output busses, equal to the product of bus nameplate output voltage and current $I_i V_i$, as follows:

$$D = \frac{P}{\sum_{i=1}^N V_i I_i},$$

For USB-PD adaptive external power supplies, at the lowest nameplate output voltage, limit the contribution from each port to 10W when calculating the derating factor.

(B) If $D \geq 1$, then loading every bus to its nameplate output current does not exceed the overall maximum output power for the power supply. In this case, load each output bus to the percentages of its nameplate output current listed in Table 4 of this section. However,

if $D < 1$, it is an indication that loading each bus to its nameplate output current will exceed the overall maximum output power for the power supply. In this case, at each loading condition, load each output bus to the appropriate percentage of its nameplate output current listed in Table 4, multiplied by the derating factor D .

(v) Minimum output current requirements. Depending on their application, some multiple-voltage adaptive external power supplies may require a minimum output current for each output bus of the power supply for correct operation. In these cases, ensure that the load current for each output at Loading Condition 4 in Table 4 of this section is greater than the minimum output current requirement. Thus, if the test method's calculated load current for a given voltage bus is smaller than the minimum output current requirement, use the minimum output current to load the bus. Record this load current in any test report.

(vi) Efficiency calculation. Calculate and record the efficiency at each loading point by dividing the UUT's measured active output power at that loading condition by the active AC input power measured at that loading condition.

(A) Calculate and record average efficiency of the UUT as the arithmetic mean of the efficiency values calculated at Loading Conditions 1, 2, 3, and 4 in Table 4 of this section.

(B) If, when tested, a UUT cannot sustain the output current at one or more of the loading conditions as specified in Table 4, the average active-mode efficiency is calculated as the average of the loading conditions for which it can sustain output.

(C) If the UUT can only sustain one output current at any of the output busses, test it at the loading condition that allows for the maximum output power on that bus (i.e. the highest output current possible at the highest output voltage on that bus).

(vii) Power consumption calculation. The power consumption of loading condition 5 (no-load) is equal to the active AC input power at that loading condition.

(2) Off-mode Measurement—If the UUT incorporates manual on-off switches, place the UUT in off-mode, and measure and record its power consumption at loading condition 5 in Table 4. The measurement of the off-mode energy consumption must conform to the requirements specified in paragraph (6)(b)(1) of this appendix, except that all manual on-off switches must be placed in the “off” position for the off-mode measurement. The UUT is considered stable if, over 5 minutes with samples taken at least once every second, the AC input power does not drift from the maximum value observed by more than 1% or 50 milliwatts, whichever is greater. Measure the off-mode power consumption of a multiple-voltage adaptive external power supply twice - once at the highest nameplate output voltage and once at the lowest.

[FR Doc. 2019-25516 Filed: 12/5/2019 8:45 am; Publication Date: 12/6/2019]